

# LARGE GUNS

ROBOT and MANUAL GUNS  
PNEUMATIC and ELECTRIC

Pneumatic Guns

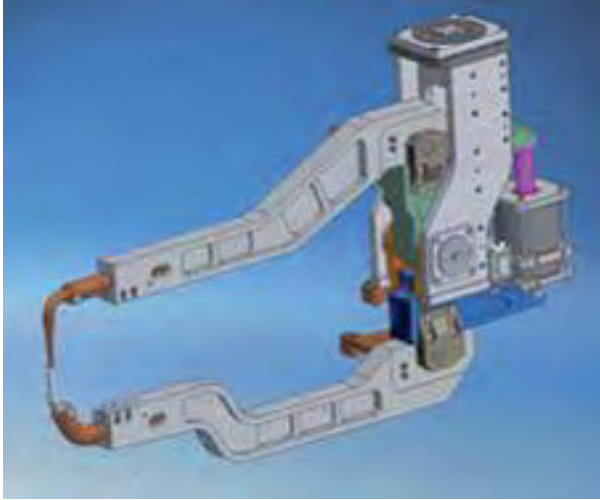

Electric Servo Guns

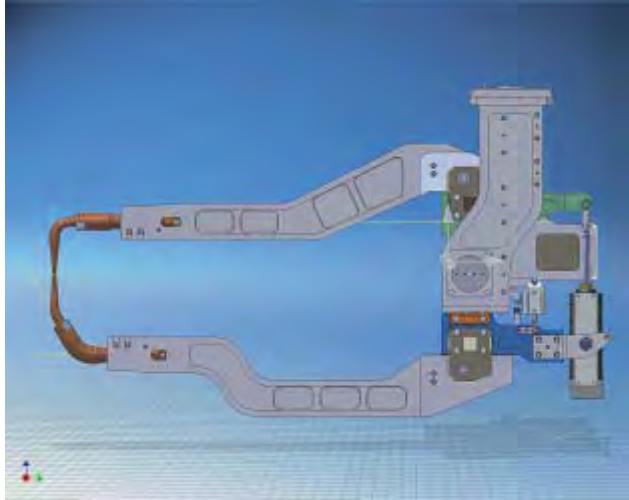

Manual Rotating Guns



Manual Standing Guns

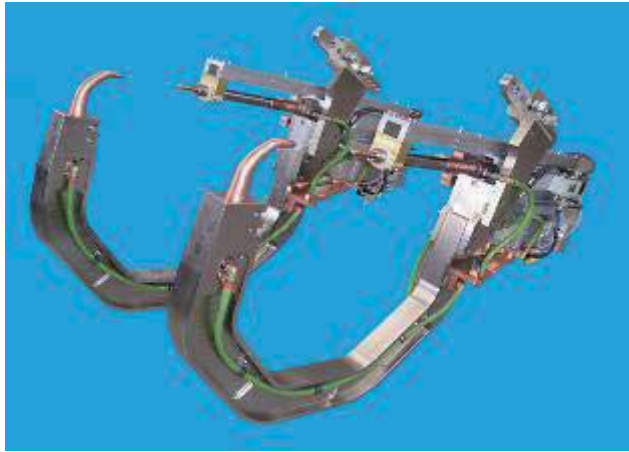

Flanges to robot



Manual Changers



Protection COVERS



CONE Reamers



This document is exclusive property of ALESSIO (I). Reproduction or use by a third party without written consent of the company is strictly forbidden, according to EC intellectual property and copyright laws. Dieses Dokument ist exclusives Eigentum von ALESSIO (I). Reproduktion oder Verwendung durch Dritte ohne schriftliche Zustimmung der Firma ist strikt untersagt, gemäß den EU Gesetzen für Copyrights und geistiges Eigentum.

Ce document est la propriété exclusive de la société ALESSIO (I). La reproduction ou l'utilisation de ce document par des tiers sans une autorisation écrite de la société est interdite selon les lois CE sur la propriété intellectuelle et le copyright. Questo documento è proprietà esclusiva del Consorzio ALESSIO (I). Ne è pertanto vietata la riproduzione o l'utilizzo con qualsiasi mezzo senza il consenso del consorzio stesso ai sensi delle leggi CE sulla proprietà intellettuale e sul copyright.



This document is exclusive property of ALESSIO (I). Reproduction or use by a third party without written consent of the company is strictly forbidden, according to EC intellectual property and copyright laws.  
 Dieses Dokument ist exklusives Eigentum von ALESSIO (I). Reproduktion oder Verwendung durch Dritte ohne schriftliche Zustimmung der Firma ist strikt untersagt, gemäß den EU Gesetzen für Copyrights und geistiges Eigentum.

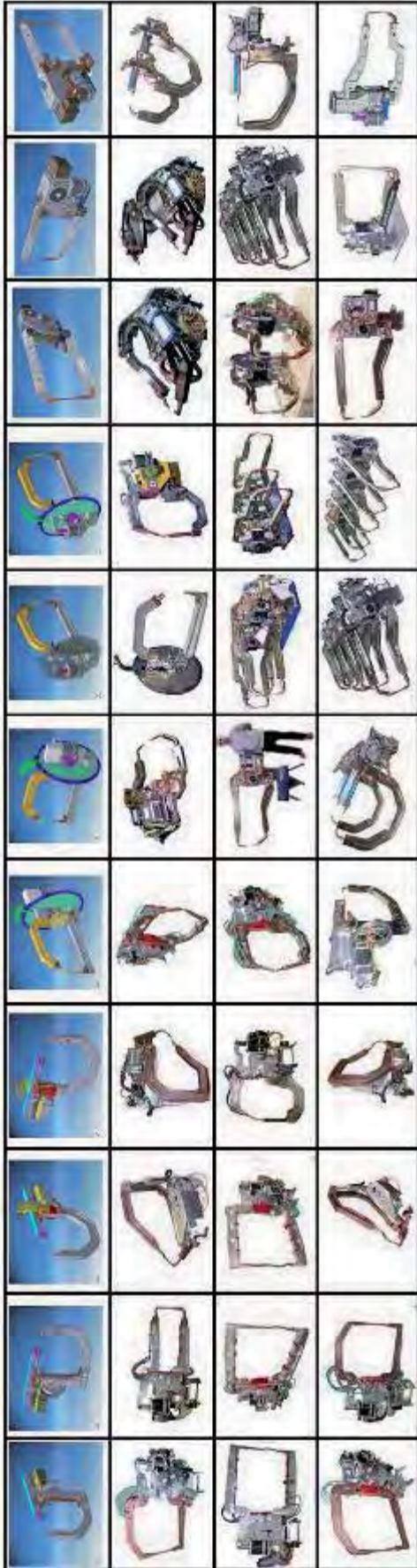

Ce document est la propriété exclusive de la société ALESSIO (I). La reproduction ou l'utilisation de ce document par des tiers sans une autorisation écrite de la société est interdite selon les lois CE sur la propriété intellectuelle et le copyright.  
 Questo documento è proprietà esclusiva del Consorzio ALESSIO (I). Ne è pertanto vietata la riproduzione o l'utilizzo con qualsiasi mezzo senza il consenso del consorzio stesso ai sensi delle leggi CE sulla proprietà intellettuale e sul copyright.



## MFDC Large Welding Guns for Robot Applications

ALESSIO - Via Rattazzi 14 – 15025 Morano sul Po (Italy)

E-mail: [ataless@tin.it](mailto:ataless@tin.it) Web site: [www.big-robotgun.com](http://www.big-robotgun.com)



These **LARGE MFDC Guns** are sold **ONLY** to integrators and builders and **NOT** to final users.

Based upon a product line of **standardized** parts, these guns are sold to manufacturers of resistance welders and to robot integrators around the world.

All we need:

- Cross sections of the sheets to be welded
- Maximum electrode welding force
- Drawing of robot flange
- The way in which the gun is to be fixed to the robot

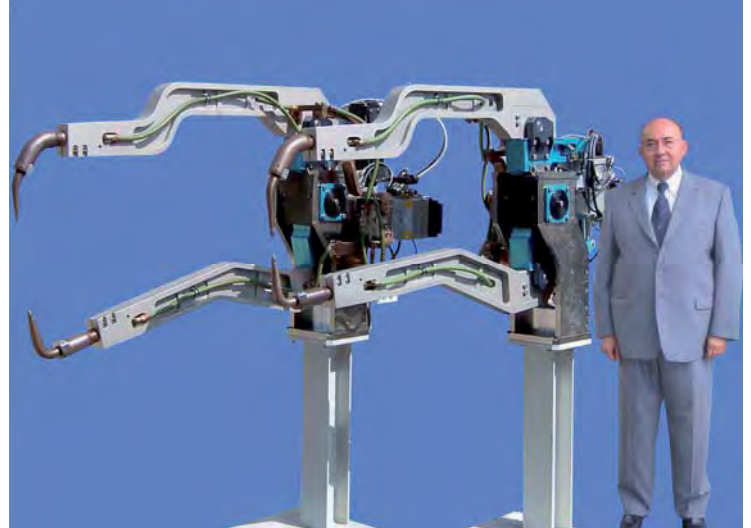

**We offer** a delivery of 7 weeks (after definition of the technical details).

**We avoid small production runs**

- You avoid problems of a few expensive, specialized units per year, the huge design and manufacturing costs...and the problems of all prototypes.

**We provide** a new, standard, predefined product to your product range.

**We provide with our 8 allied companies** worldwide, each at the vanguard in their sector:

- 1000 Hz MFDC welding
- Pneumatic, double-stroke cylinders with 3 bores (140-160-200mm)
- Servo-cylinders up to 5000 kg Weld Force
- Independent drivers and controls for servo-cylinders as required

**We complement** these Large Guns with a range of accessories like:

- Standard mountings
- Standard Robot flanges
- Standard manual gun-changers
- Electrode dressers
- Automatic electrode changers
- Close-circuit units for water cooling
- Stands to service the guns or to store them
- Protection covers (fire-resistant and silicon-free)

To minimize the costs, all technical and commercial definitions are made by e-mail.

**We provide** to integrators and builders (our commercial allies) a technical literature and support with:

- a **CD** with 200 pages showing manufacturing details of guns and their application
- a **DVD** showing in a film these Large robot-guns in action in the Auto Industry
- a **technical booklet** describing the advantages of MFDC welding and of Servo-guns

**We can provide** for welding shows in their booths or premises the **2 samples** shown above, made for a routing exhibition around the world



# LARGE GUNS

## For Robot application or Manual Operation, Pneumatic or Servo-driven, Standard or Special with Arm Length up to 2 m

In every spot-welding line there are always some subassemblies that need very long and special-shape arms to enter difficult welding areas.

In this cases the guns must be studied all over again with high design costs and with all problems of prototypes.

Our company, after manufacturing more than 200 LARGE Guns in the past 10 years, defined a flexible project of UNIVERSAL MFDC GUNS with a STANDARD BODY, being produced in small batches of 20 units.

They had an important success and they have been highly appreciated by engineering companies (who avoided to study new guns all over again) and by production engineers who could use a well experimented product.

The 84% of their components is STANDARD and their manufacturing in small batches allow cost reduction and no risk tied to prototypes.

The examples following in the next pages are showing:

- 1) The ideas at the base of the project
- 2) The structure of STANDARD bodies
- 3) The manufacturinh methods
- 4) The machining operations
- 5) The components
- 6) The small batches
- 7) The accessories:
  - Fixing brackets to the robots
  - Flanges to robot head
  - Manual gun changers
- 8) Electric, pneumatic and cooling installations
- 9) Applications
- 10) Off-line simulation
- 11) Others



# PRE-ENGINEERING

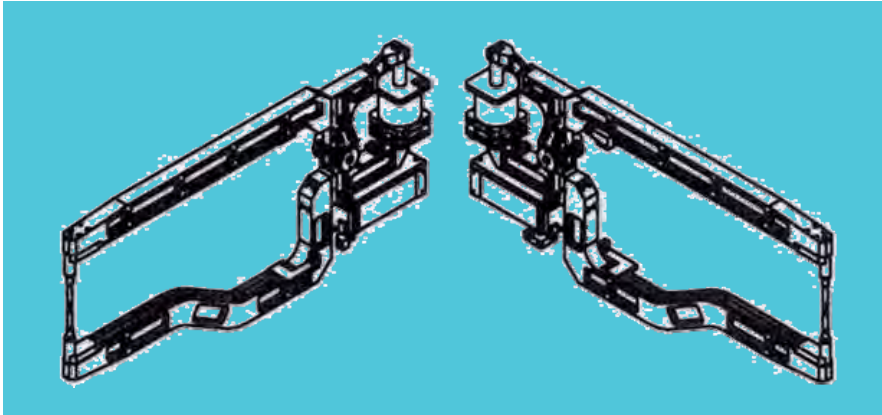

- In the FIRST PHASE:
- 1) customers submit the files showing the cross-sections of sheets to be welded.
  - 2) we e-mail them a 3D CATIA pre-study that they can use for an off-line simulation
  - 3) after refining details and approval we design the guns (handed = LH or RH), their brackets and all wanted accessorie

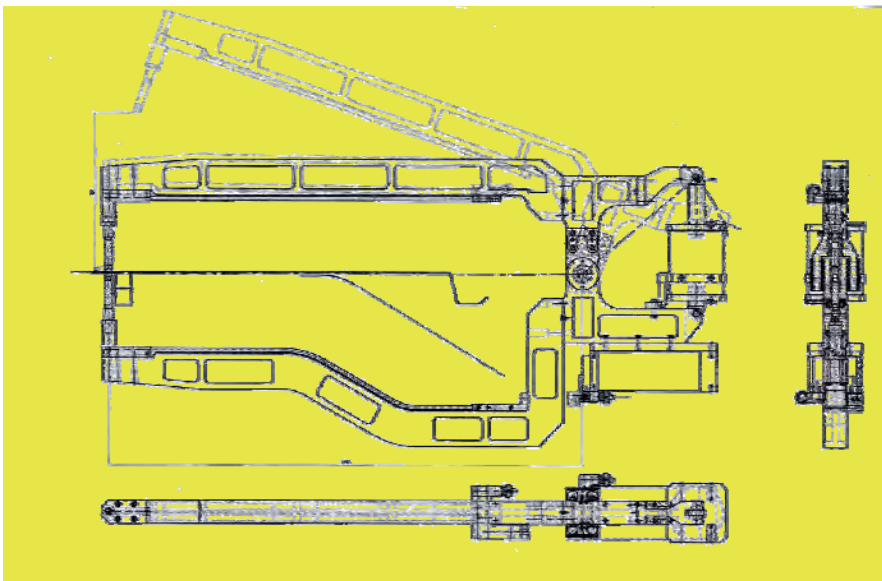
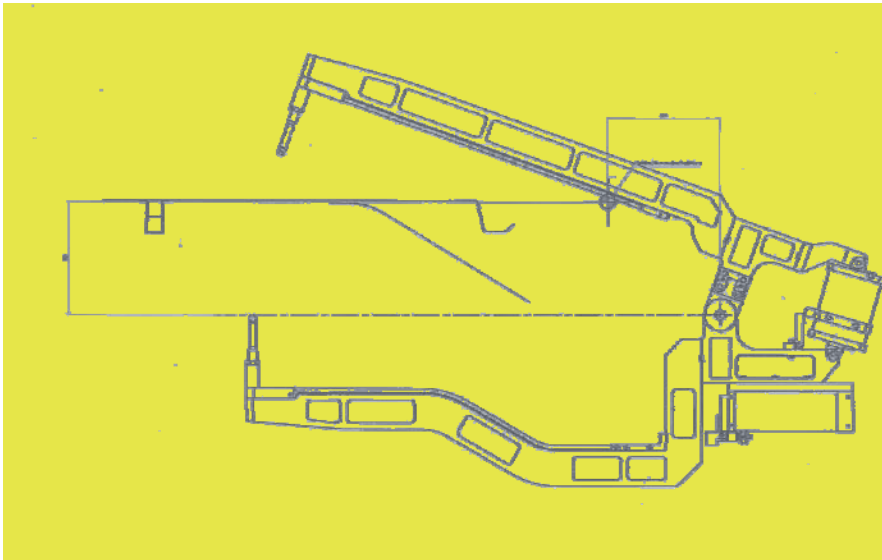

# STRESS Analysis

Before manufacturing, all mechanical structures, both of gun bodies and arms+electrode-holders+electrodes go through a stress analysis. The max. allowable forces are simulated and we always supply, with the instructions manual, both the “Colour Stress Analysis” Map and the table showing the points of maximum stress.

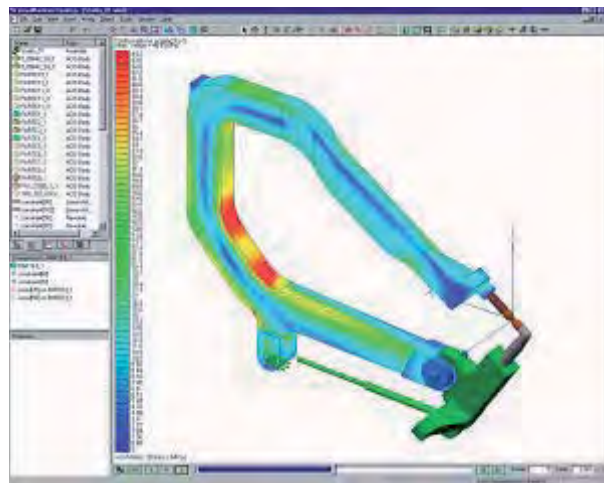
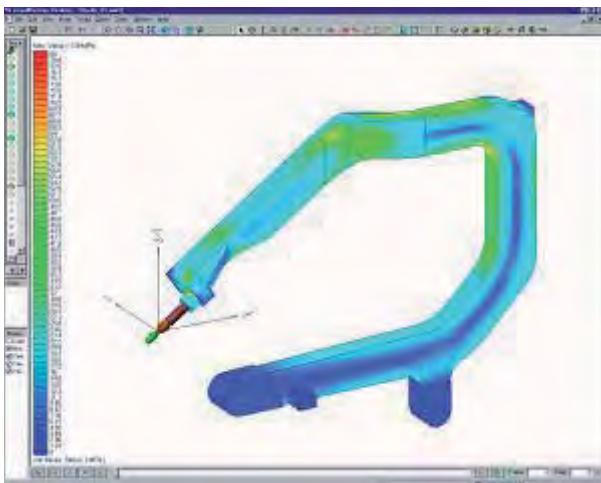
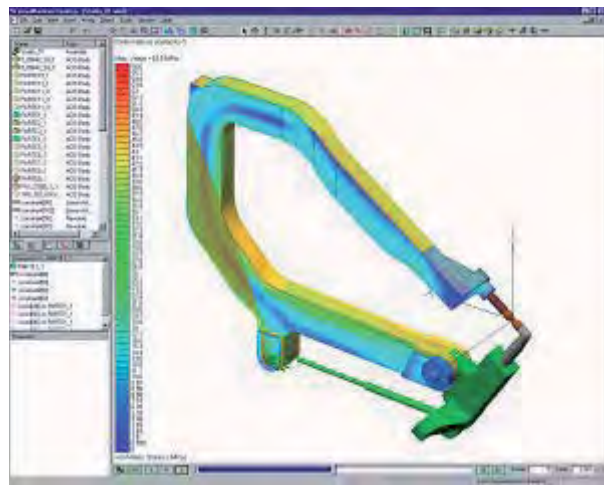
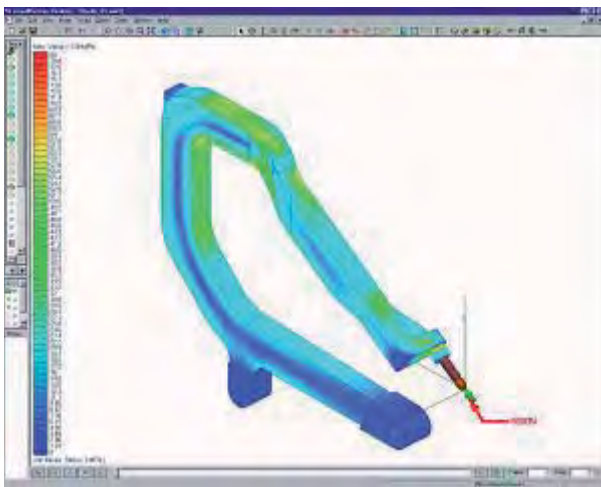



# New series of LARGE Robot Guns **SCB** type

A standard body  
common to all gun configurations  
made in high-resistance Aluminium Alloy  
allowing **1,5 m** arm length and **1 m** arm width.

A cylinder with different strokes both approach and weld stroke

Mountings with a vertical, back or lateral fixing

Only 14% of components (arms and mountings)  
are specifically designed for each new gun

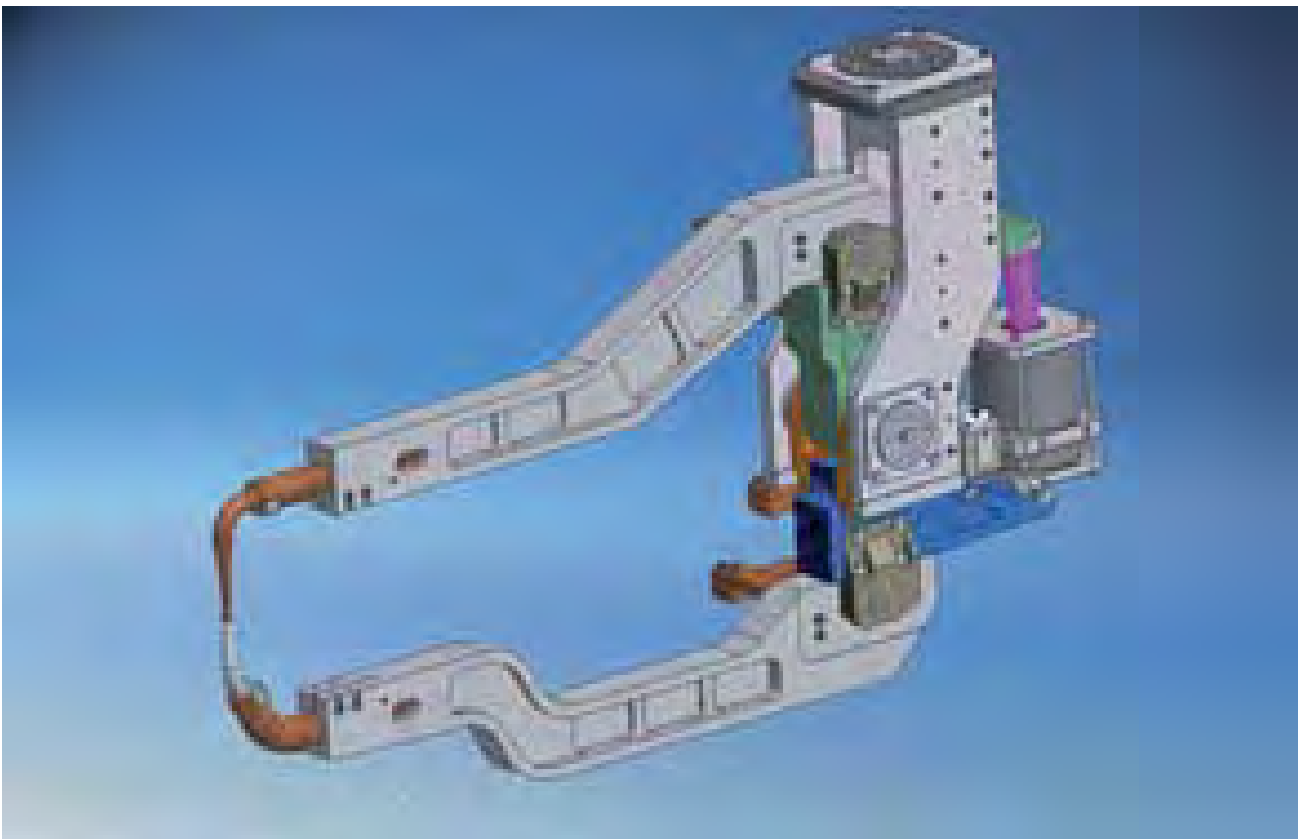

## Main features of SCB series LARGE STANDARG GUNS

These guns have been designed to use a **standard** weld gun **body** to enable us to provide weld guns of up to 1,500 mm throat length and distance between arms of up to 1,000 mm.

These guns are predominantly used in under body and roof lines, however the design can be adapted for many other applications such as Van and Truck Body sides etc.

The weld guns are manufactured from Aerospace grade 7075 Aluminium offering **great strength** whilst being **easy to machine** and **light weight**.

All components are **machined from solid** and no cast aluminium parts are used anywhere on the completed weld guns. This ensures the final weld guns are very robust and will provide many years of service.

To aid both the design , manufacturing and service process of these guns the **main pivot system is common**. This allows many variations to be manufactured using a common gun body.

The pivot system features the use of **dual Balancing cylinders** allowing fine tuning of the gun balancing system when operated independently to the main weld cylinder.

The weld guns come fitted with an SMC **proportional air valve** as standard for the regulation of the weld pressure. Alternative manufacturers equipment can be fitted if required.

The weld guns can be built **Handed** so that there would be a **LH** and/or a **RH** variant of each design to allow better integration into the assembly lines.

The weld guns can be supplied fitted with **various stroke cylinders** to suite the design requirements of the project and are supplied ready to fit and use on the robot of chose. This, along with the use of Medium Frequency Transformers, offers our customers a high quality alternative to the use of older style guns with hip mounted transformers.



## Left and Right views of a gun with a lateral and very compact mounting

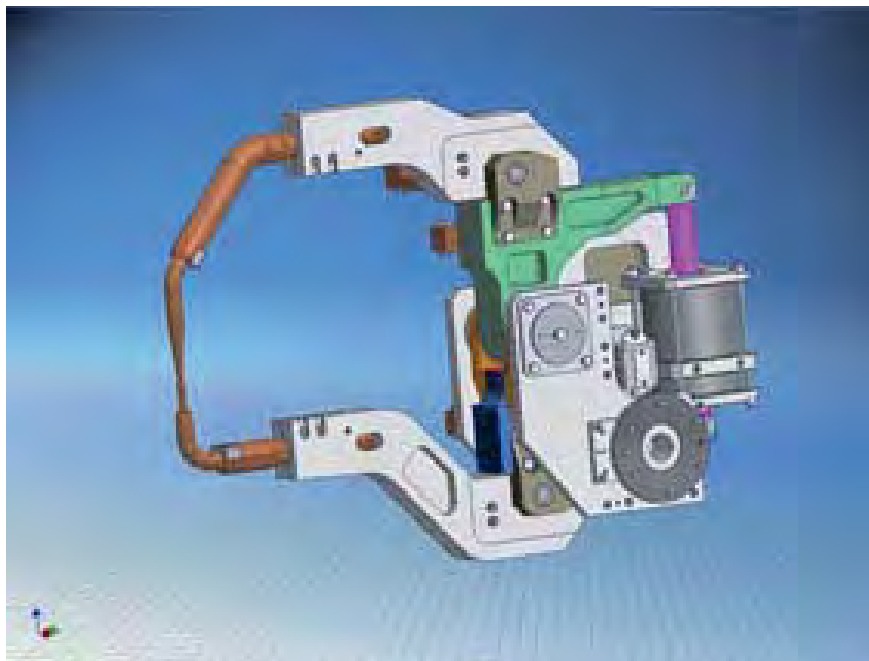
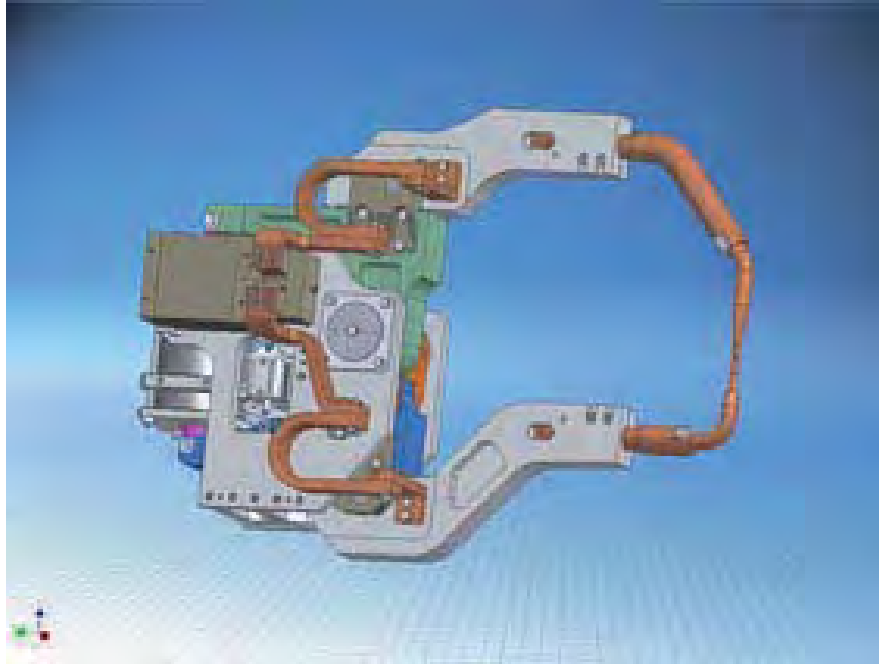

This document is exclusive property of ALESSIO (I). Reproduction or use by a third party without written consent of the company is strictly forbidden, according to EC intellectual property and copyright laws.  
Dieses Dokument ist exklusives Eigentum von ALESSIO (I). Reproduktion oder Verwendung durch Dritte ohne schriftliche Zustimmung der Firma ist strikt untersagt, gemäß den EU Gesetzen für Copyrights und geistiges Eigentum.

Ce document est la propriété exclusive de la société ALESSIO (I). La reproduction ou l'utilisation de ce document par des tiers sans une autorisation écrite de la société est interdite selon les lois CE sur la propriété intellectuelle et le copyright.  
Questo documento è proprietà esclusiva del Consorzio ALESSIO (I). Ne è pertanto vietata la riproduzione o l'utilizzo con qualsiasi mezzo senza il consenso del consorzio stesso ai sensi delle leggi CE sulla proprietà intellettuale e sul copyright.

## Different views of a gun with a vertical mounting and a very large secondary area

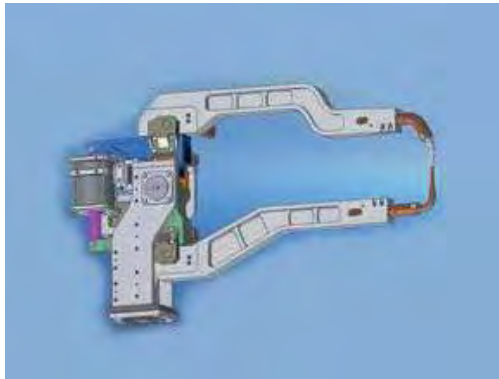
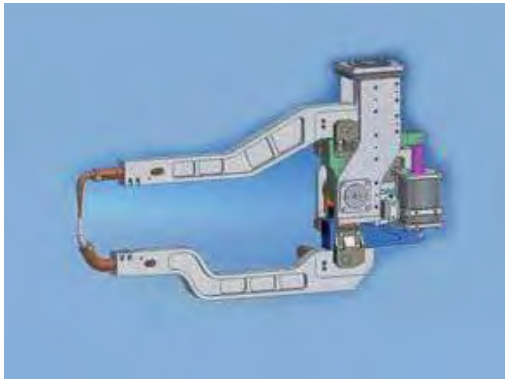
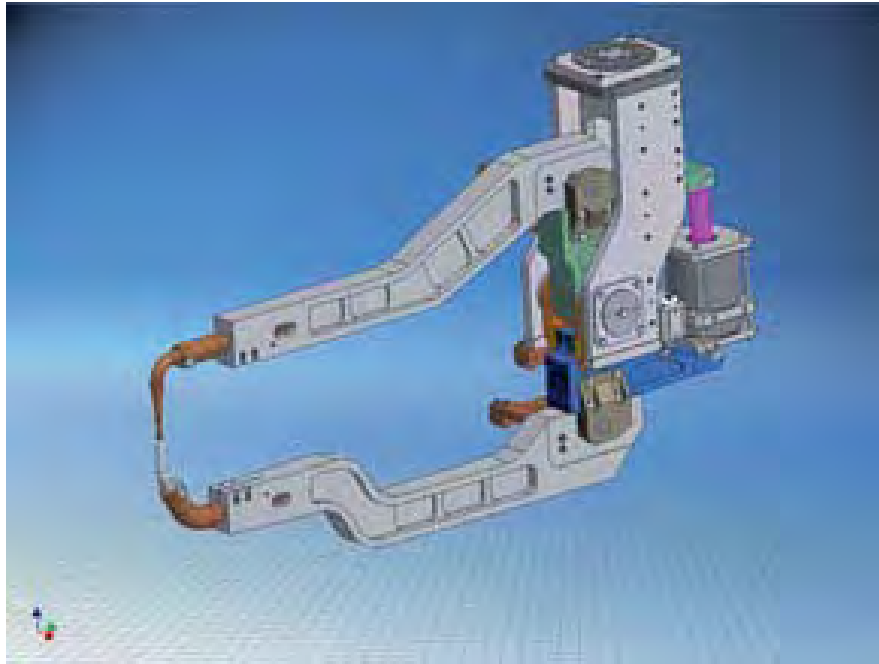

This document is exclusive property of ALESSIO (I). Reproduction or use by a third party without written consent of the company is strictly forbidden, according to EC intellectual property and copyright laws.  
Dieses Dokument ist exklusives Eigentum von ALESSIO (I). Reproduktion oder Verwendung durch Dritte ohne schriftliche Zustimmung der Firma ist strikt untersagt, gemäß den EU Gesetzen für Copyrights und geistiges Eigentum.

Ce document est la propriété exclusive de la société ALESSIO (I). La reproduction ou l'utilisation de ce document par des tiers sans une autorisation écrite de la société est interdite selon les lois CE sur la propriété intellectuelle et le copyright.  
Questo documento è proprietà esclusiva del Consorzio ALESSIO (I). Ne è pertanto vietata la riproduzione o l'utilizzo con qualsiasi mezzo senza il consenso del consorzio stesso ai sensi delle leggi CE sulla proprietà intellettuale e sul copyright.



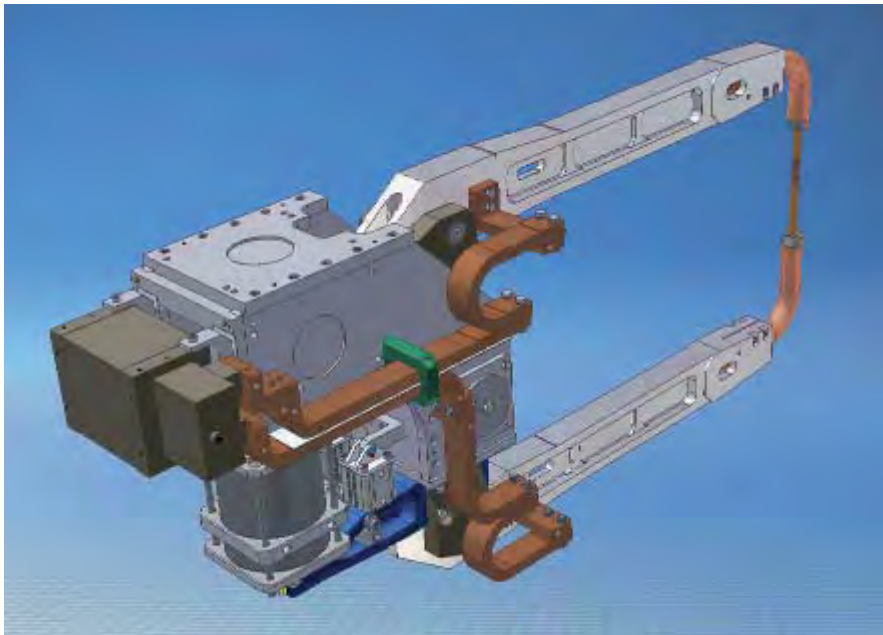
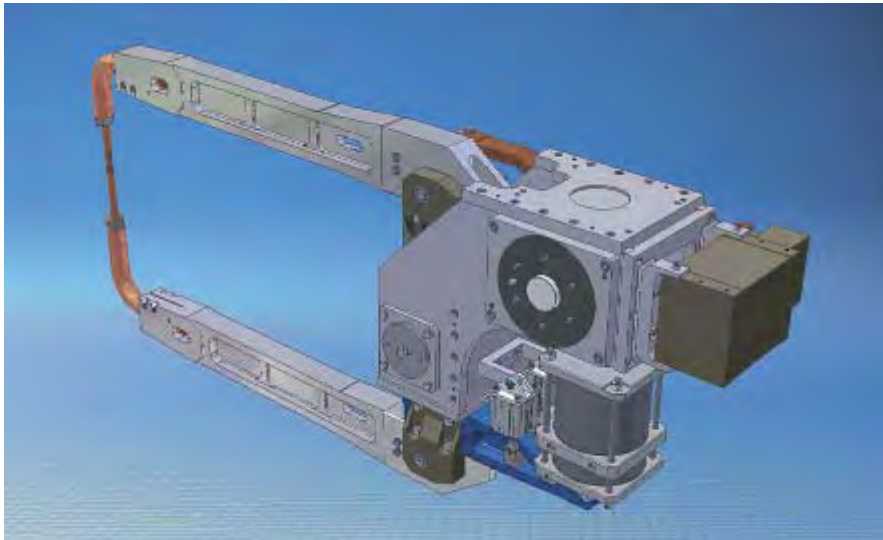
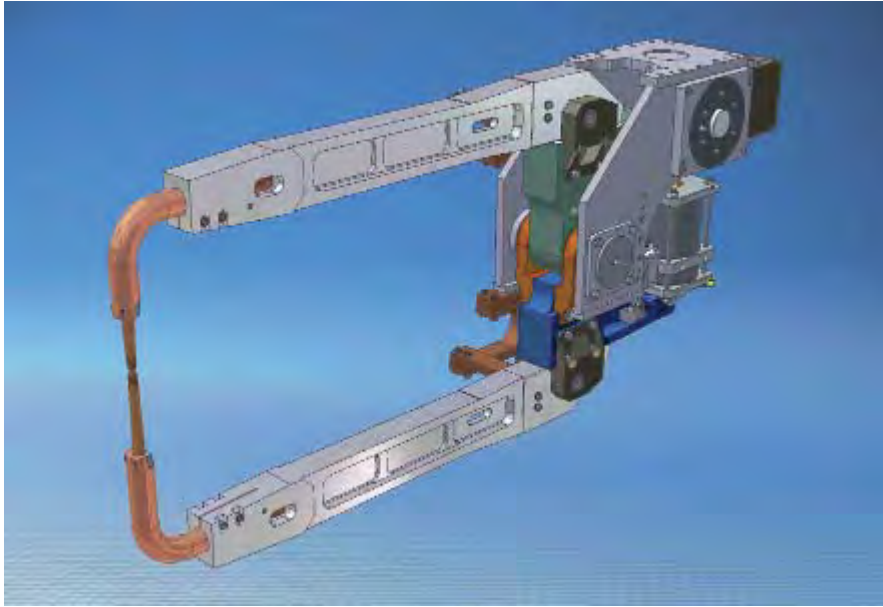

This document is exclusive property of ALESSIO (I). Reproduction or use by a third party without written consent of the company is strictly forbidden, according to EC intellectual property and copyright laws.  
Dieses Dokument ist exklusives Eigentum von ALESSIO (I). Reproduktion oder Verwendung durch Dritte ohne schriftliche Zustimmung der Firma ist strikt untersagt, gemäss den EU Gesetzen für Copyrights und geistiges Eigentum.

Ce document est la propriété exclusive de la société ALESSIO (I). La reproduction ou l'utilisation de ce document par des tiers sans une autorisation écrite de la société est interdite selon les lois CE sur la propriété intellectuelle et le copyright.  
Questo documento è proprietà esclusiva del Consorzio ALESSIO (I). Ne è pertanto vietata la riproduzione o l'utilizzo con qualsiasi mezzo senza il consenso del consorzio stesso ai sensi delle leggi CE sulla proprietà intellettuale e sul copyright.

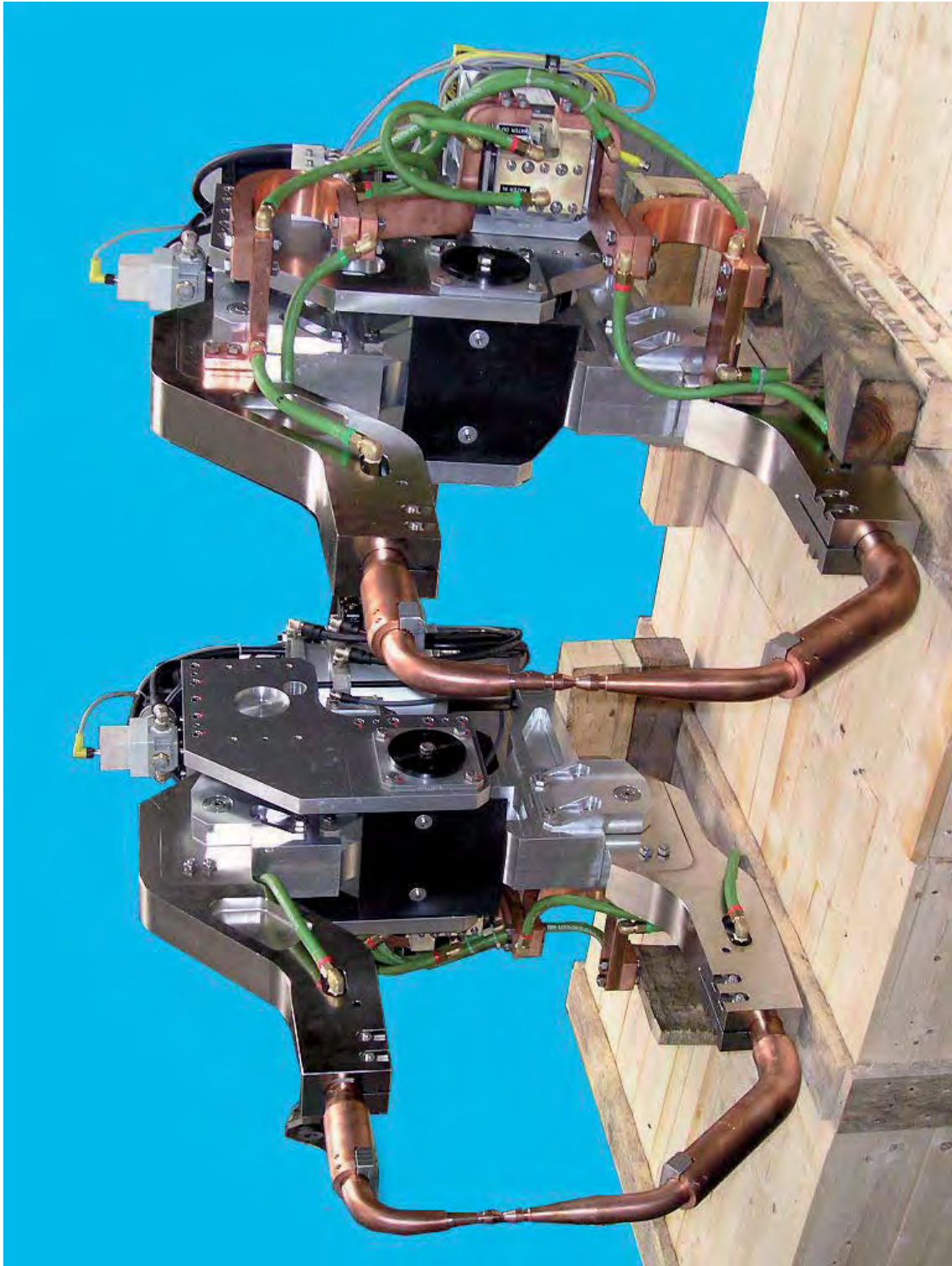

This document is exclusive property of ALESSIO (I). Reproduction or use by a third party without written consent of the company is strictly forbidden, according to EC intellectual property and copyright laws.  
Dieses Dokument ist exklusives Eigentum von ALESSIO (I). Reproduktion oder Verwendung durch Dritte ohne schriftliche Zustimmung der Firma ist strikt untersagt, gemäß den EU Gesetzen für Copyrights und geistiges Eigentum.

Ce document est la propriété exclusive de la société ALESSIO (I). La reproduction ou l'utilisation de ce document par des tiers sans une autorisation écrite de la société est interdite selon les lois CE sur la propriété intellectuelle et le copyright.  
Questo documento è proprietà esclusiva del Consorzio ALESSIO (I). Ne è pertanto vietata la riproduzione o l'utilizzo con qualsiasi mezzo senza il consenso del consorzio stesso ai sensi delle leggi CE sulla proprietà intellettuale e sul copyright.



This document is exclusive property of ALESSIO (I). Reproduction or use by a third party without written consent of the company is strictly forbidden, according to EC intellectual property and copyright laws.  
Dieses Dokument ist exklusives Eigentum von ALESSIO (I). Reproduktion oder Verwendung durch Dritte ohne schriftliche Zustimmung der Firma ist strikt untersagt, gemäß den EU Gesetzen für Copyrights und geistiges Eigentum.

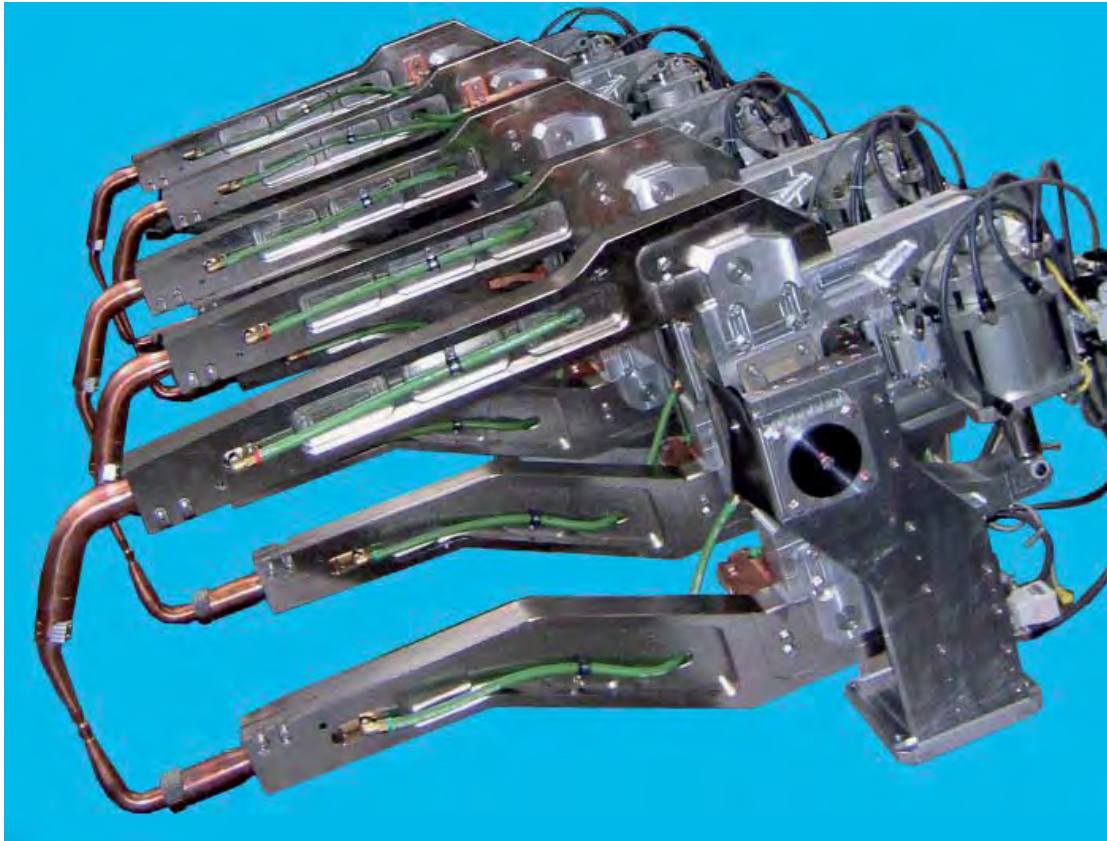

Ce document est la propriété exclusive de la société ALESSIO (I). La reproduction ou l'utilisation de ce document par des tiers sans une autorisation écrite de la société est interdite selon les lois CE sur la propriété intellectuelle et le copyright.  
Questo documento è proprietà esclusiva del Consorzio ALESSIO (I). Ne è pertanto vietata la riproduzione o l'utilizzo con qualsiasi mezzo senza il consenso del consorzio stesso ai sensi delle leggi CE sulla proprietà intellettuale e sul copyright.



This document is exclusive property of ALESSIO (I). Reproduction or use by a third party without written consent of the company is strictly forbidden, according to EC intellectual property and copyright laws.  
Dieses Dokument ist exklusives Eigentum von ALESSIO (I). Reproduktion oder Verwendung durch Dritte ohne schriftliche Zustimmung der Firma ist strikt untersagt, gemäß den EU Gesetzen für Copyrights und geistiges Eigentum.

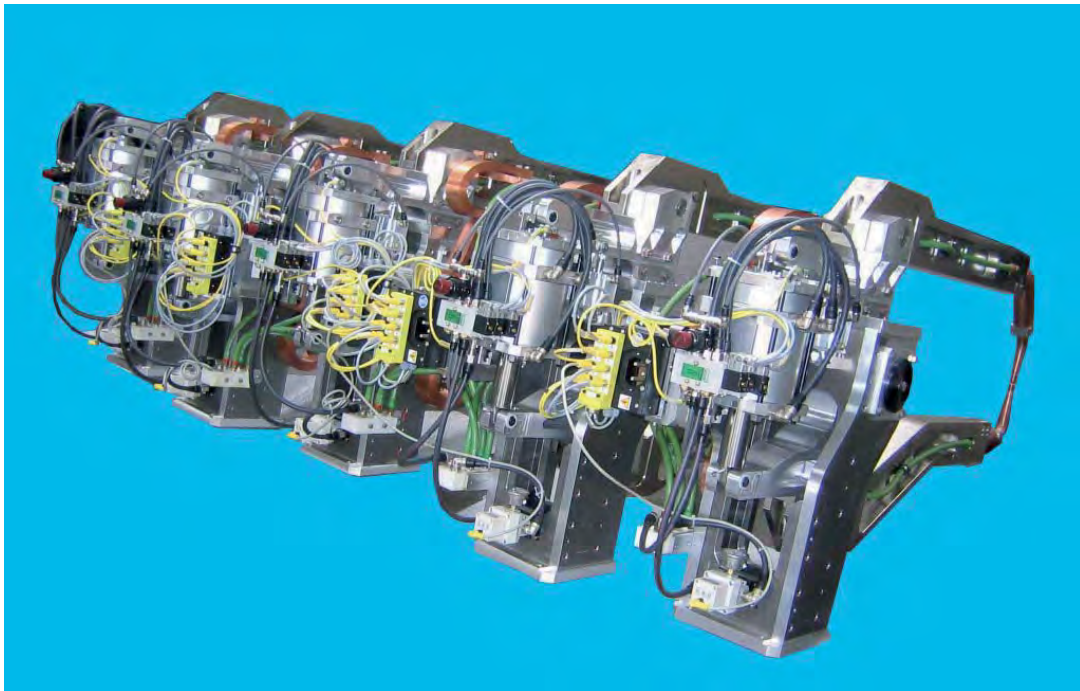
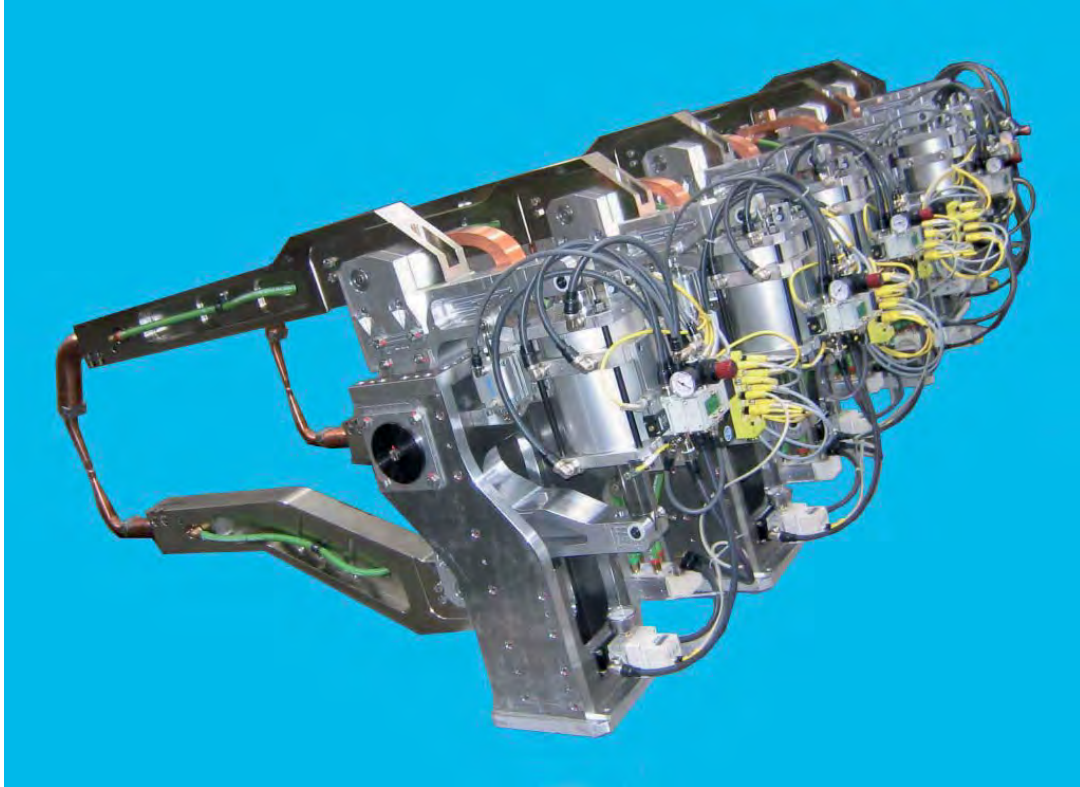

Ce document est la propriété exclusive de la société ALESSIO (I). La reproduction ou l'utilisation de ce document par des tiers sans une autorisation écrite de la société est interdite selon les lois CE sur la propriété intellectuelle et le copyright.  
Questo documento è proprietà esclusiva del Consorzio ALESSIO (I). Ne è pertanto vietata la riproduzione o l'utilizzo con qualsiasi mezzo senza il consenso del consorzio stesso ai sensi delle leggi CE sulla proprietà intellettuale e sul copyright.

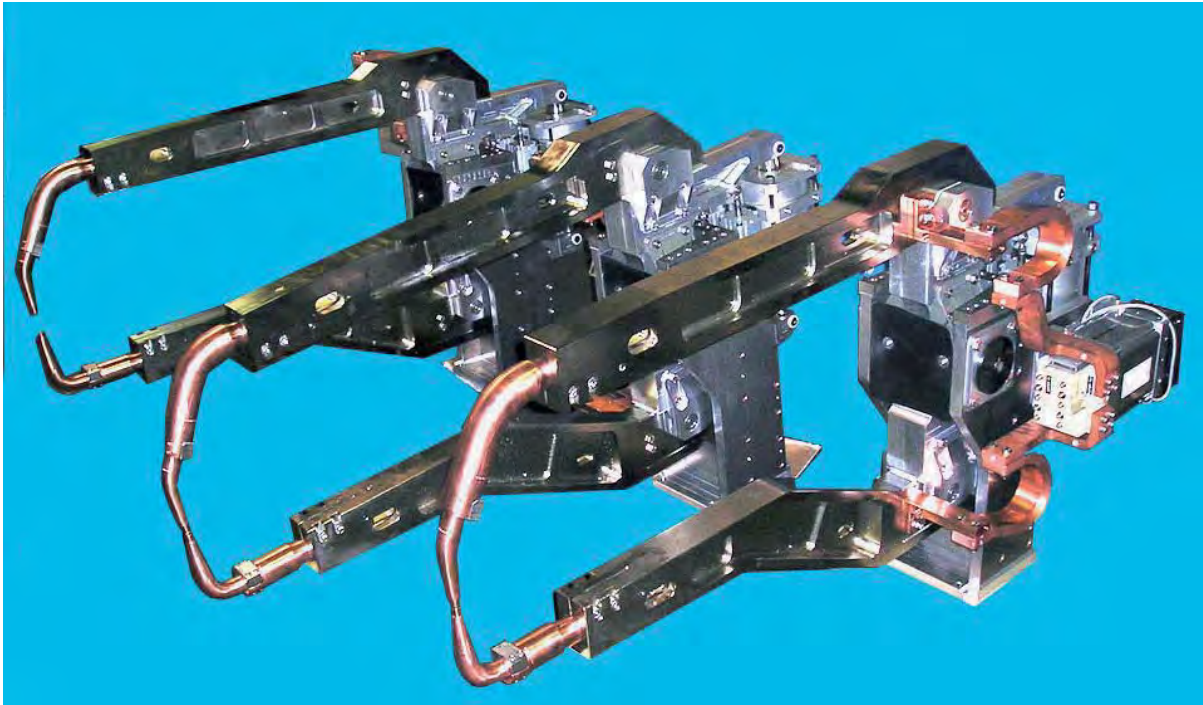
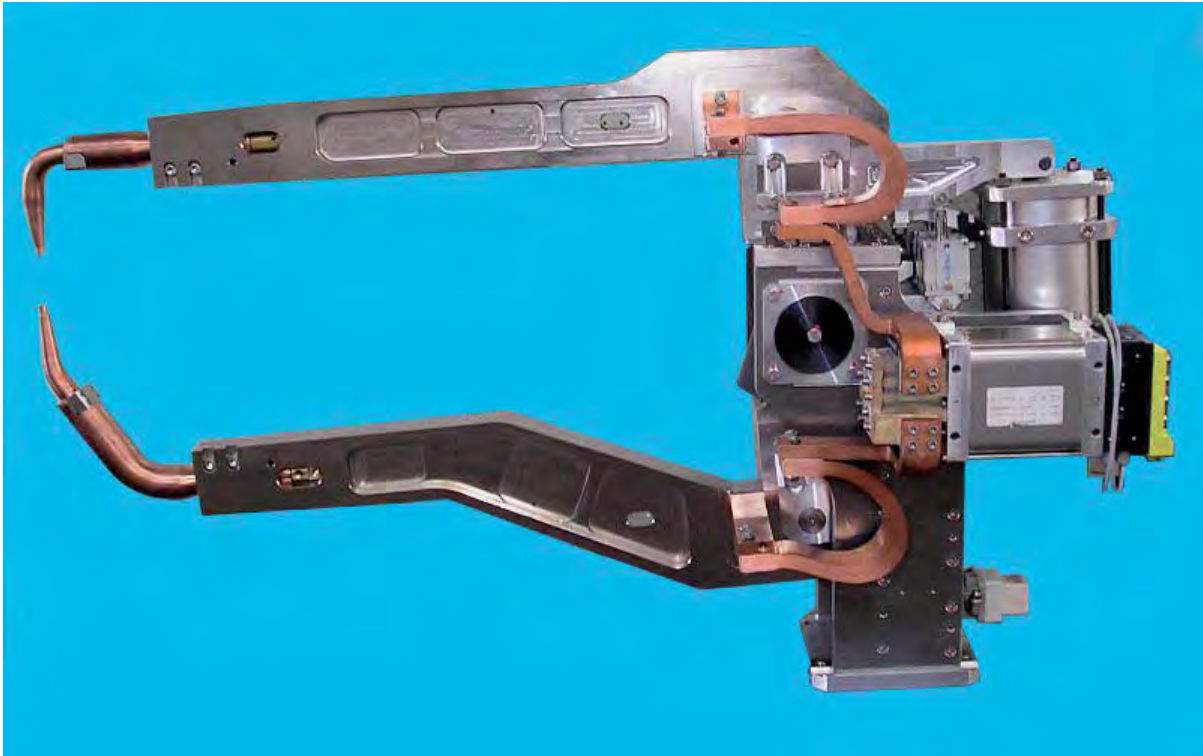

This document is exclusive property of ALESSIO (I). Reproduction or use by a third party without written consent of the company is strictly forbidden, according to EC intellectual property and copyright laws.  
Dieses Dokument ist exklusives Eigentum von ALESSIO (I). Reproduktion oder Verwendung durch Dritte ohne schriftliche Zustimmung der Firma ist strikt untersagt, gemäss den EU Gesetzen für Copyrights und geistiges Eigentum.

Ce document est la propriété exclusive de la société ALESSIO (I). La reproduction ou l'utilisation de ce document par des tiers sans une autorisation écrite de la société est interdite selon les lois CE sur la propriété intellectuelle et le copyright.  
Questo documento è proprietà esclusiva del Consorzio ALESSIO (I). Ne è pertanto vietata la riproduzione o l'utilizzo con qualsiasi mezzo senza il consenso del consorzio stesso ai sensi delle leggi CE sulla proprietà intellettuale e sul copyright.



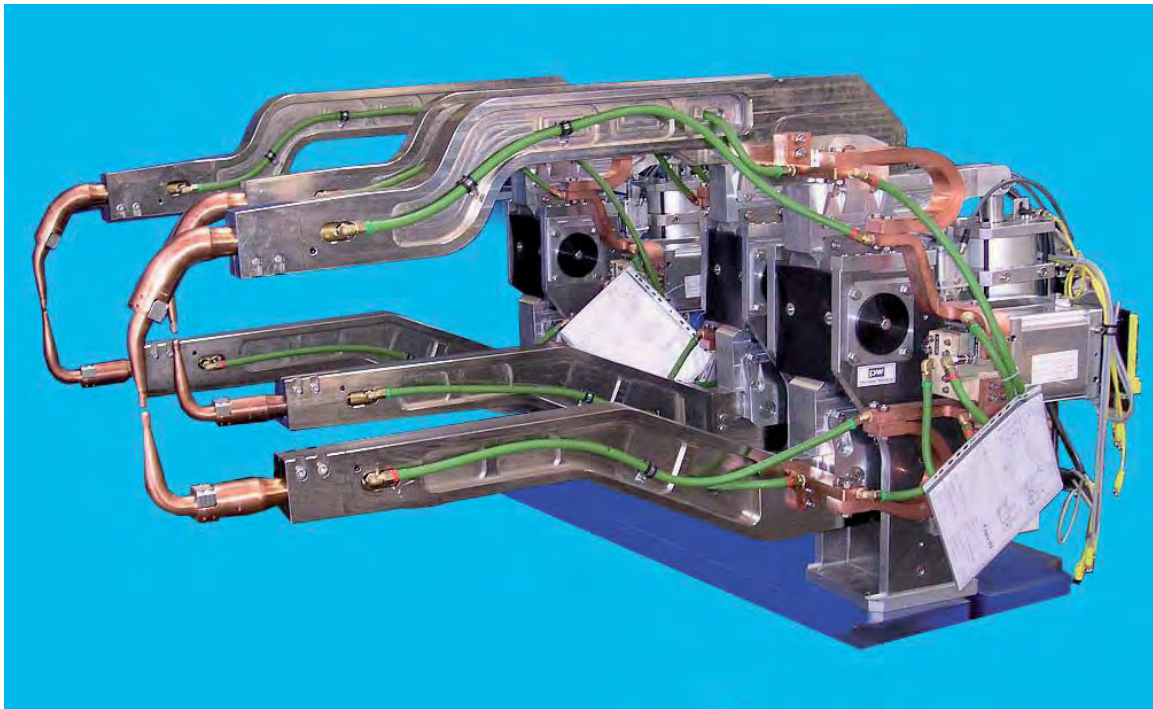
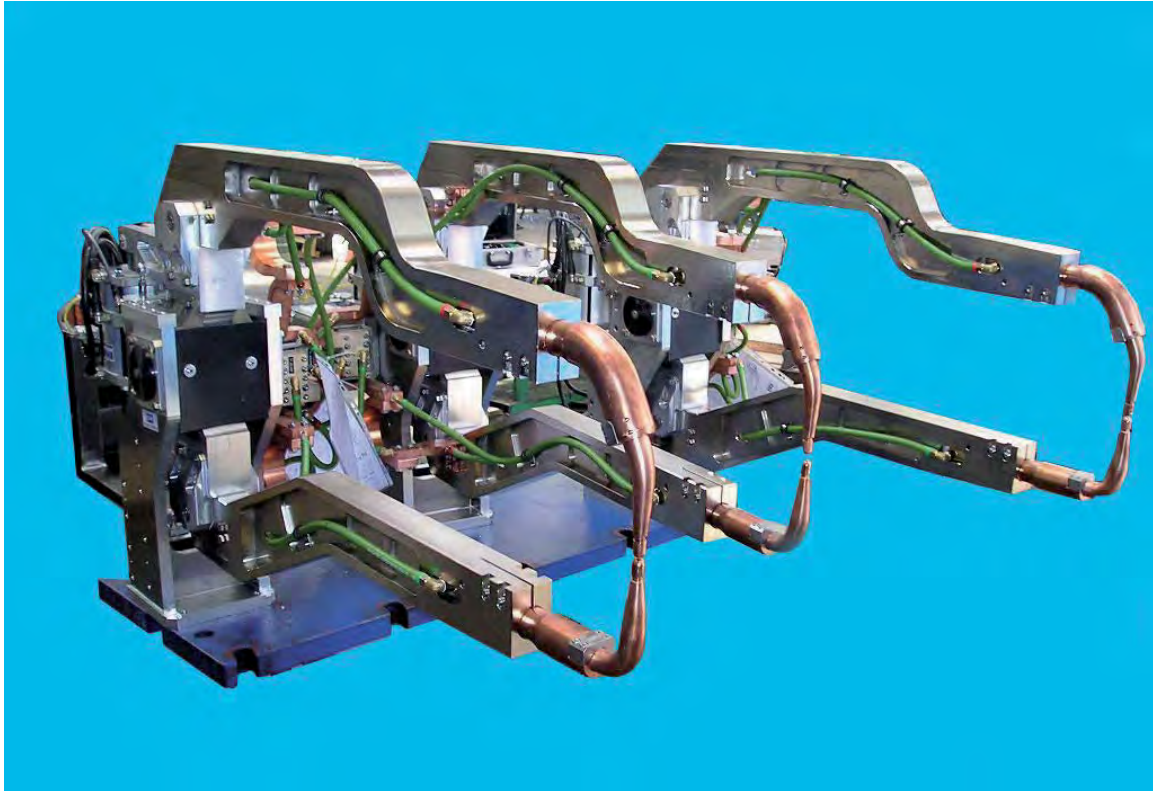

This document is exclusive property of ALESSIO (I). Reproduction or use by a third party without written consent of the company is strictly forbidden, according to EC intellectual property and copyright laws.  
Dieses Dokument ist exklusives Eigentum von ALESSIO (I). Reproduktion oder Verwendung durch Dritte ohne schriftliche Zustimmung der Firma ist strikt untersagt, gemäß den EU Gesetzen für Copyrights und geistiges Eigentum.

Ce document est la propriété exclusive de la société ALESSIO (I). La reproduction ou l'utilisation de ce document par des tiers sans une autorisation écrite de la société est interdite selon les lois CE sur la propriété intellectuelle et le copyright.  
Questo documento è proprietà esclusiva del Consorzio ALESSIO (I). Ne è pertanto vietata la riproduzione o l'utilizzo con qualsiasi mezzo senza il consenso del consorzio stesso ai sensi delle leggi CE sulla proprietà intellettuale e sul copyright.



# Drawings of the most requested guns

This document is exclusive property of ALESSIO (I). Reproduction or use by a third party without written consent of the company is strictly forbidden, according to EC intellectual property and copyright laws.  
Dieses Dokument ist exklusives Eigentum von ALESSIO (I). Reproduktion oder Verwendung durch Dritte ohne schriftliche Zustimmung der Firma ist strikt untersagt, gemäß den EU Gesetzen für Copyrights und geistiges Eigentum.

Ce document est la propriété exclusive de la société ALESSIO (I). La reproduction ou l'utilisation de ce document par des tiers sans une autorisation écrite de la société est interdite selon les lois CE sur la propriété intellectuelle et le copyright.  
Questo documento è proprietà esclusiva del Consorzio ALESSIO (I). Ne è pertanto vietata la riproduzione o l'utilizzo con qualsiasi mezzo senza il consenso del consorzio stesso ai sensi delle leggi CE sulla proprietà intellettuale e sul copyright.

This document is exclusive property of ALESSIO (I). Reproduction or use by a third party without written consent of the company is strictly forbidden, according to EC intellectual property and copyright laws.  
Dieses Dokument ist exklusives Eigentum von ALESSIO (I). Reproduktion oder Verwendung durch Dritte ohne schriftliche Zustimmung der Firma ist strikt untersagt, gemäß den EU Gesetzen für Copyrights und geistiges Eigentum.

Carico su elettrodi - Electrode force	Cilindro - Cylinder	Apertura pinza - Gun working stroke	Trasformatore
Carico a 0.1 MPa: Force at 0.1 MPa:	160 mm	Apertura di saldatura - Welding stroke: 30 mm	-
Carico a di esercizio: Welding force:	Alessaggio, saldatura Cylinder Weld Dia: 160 mm	Braccio superiore - mm	Cambio pinza
Carico a consigliato: -;	Corsa avvicinamento: Supplementary stroke: 25 mm	Apertura di stivolo - Supplementary stroke: 250 mm	-
	Corsa di saldatura Weld Stroke:	Braccio inferiore - mm	

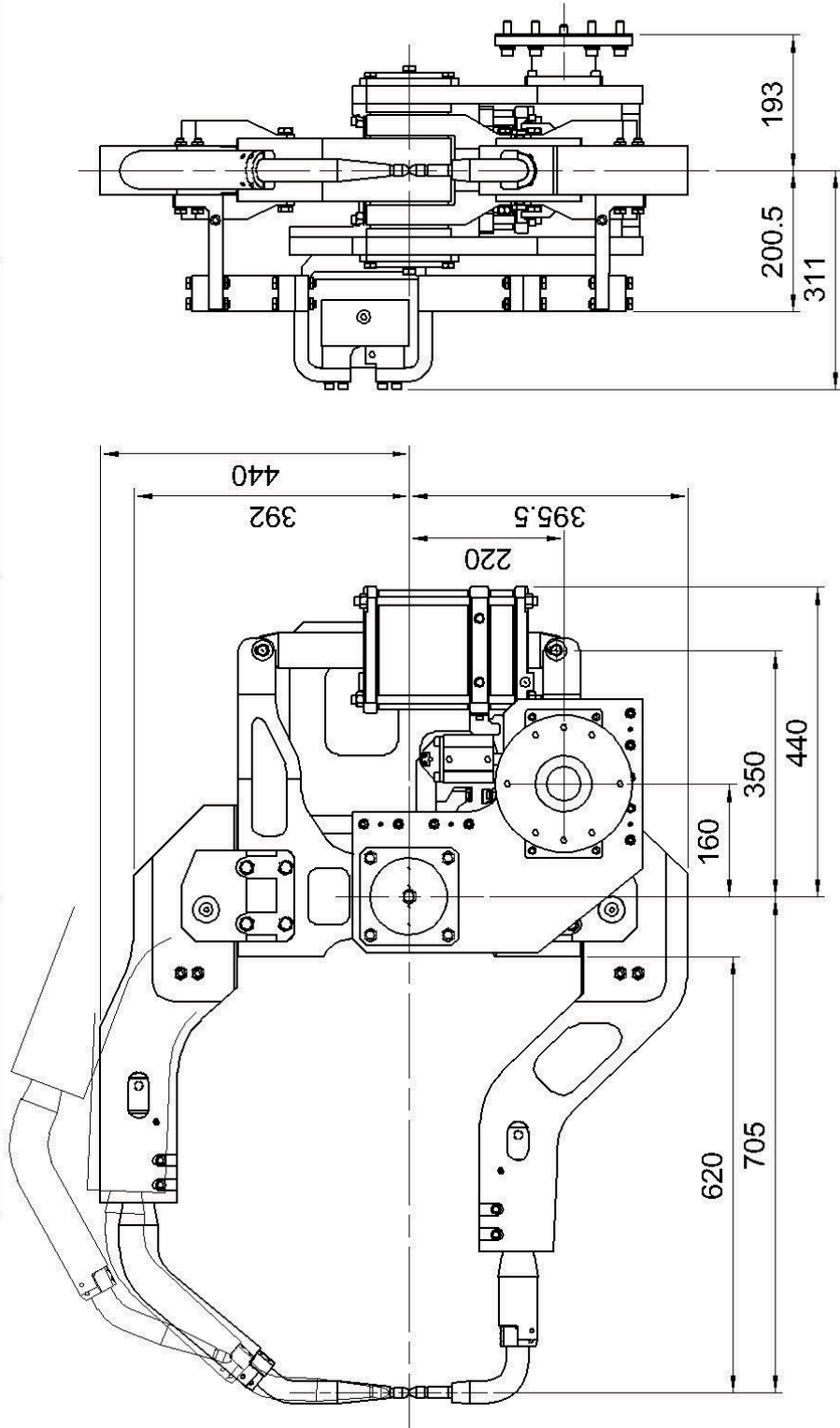

Ce document est la propriété exclusive de la société ALESSIO (I). La reproduction ou l'utilisation de ce document par des tiers sans une autorisation écrite de la société est interdite selon les lois CE sur la propriété intellectuelle et le copyright.  
Questo documento è proprietà esclusiva del Consorzio ALESSIO (I). Ne è pertanto vietata la riproduzione o l'utilizzo con qualsiasi mezzo senza il consenso del consorzio stesso ai sensi delle leggi CE sulla proprietà intellettuale e sul copyright.

This document is exclusive property of ALESSIO (I). Reproduction or use by a third party without written consent of the company is strictly forbidden, according to EC intellectual property and copyright laws.  
 Dieses Dokument ist exklusives Eigentum von ALESSIO (I). Reproduktion oder Verwendung durch Dritte ohne schriftliche Zustimmung der Firma ist strikt untersagt, gemäß den EU Gesetzen für Copyrights und geistiges Eigentum.

Carico su elettrodi - Electrode force	Cilindro - Cylinder	Apertura pinza - Gun working stroke	Trasformatore
Carico a 0.1 MPa: Force at 0.1 MPa: Carico a di esercizio: Welding force: Carico a consigliato: -	Alésaggio, precorso: Cylinder Dia: Alésaggio, saldatura Cylinder Weld Dia: Corso avvicinamento: Supplementary stroke: Corso di saldatura Weld Stroke:	Apertura di saldatura - Welding stroke Braccio superiore Braccio inferiore Apertura di svincolo - Supplementary stroke Braccio superiore Braccio inferiore	- Cambio pinza -
54 daN - daN a - MPa - MPa	160 mm 160 mm 97 mm 48 mm	133 mm - mm 449 mm - mm	

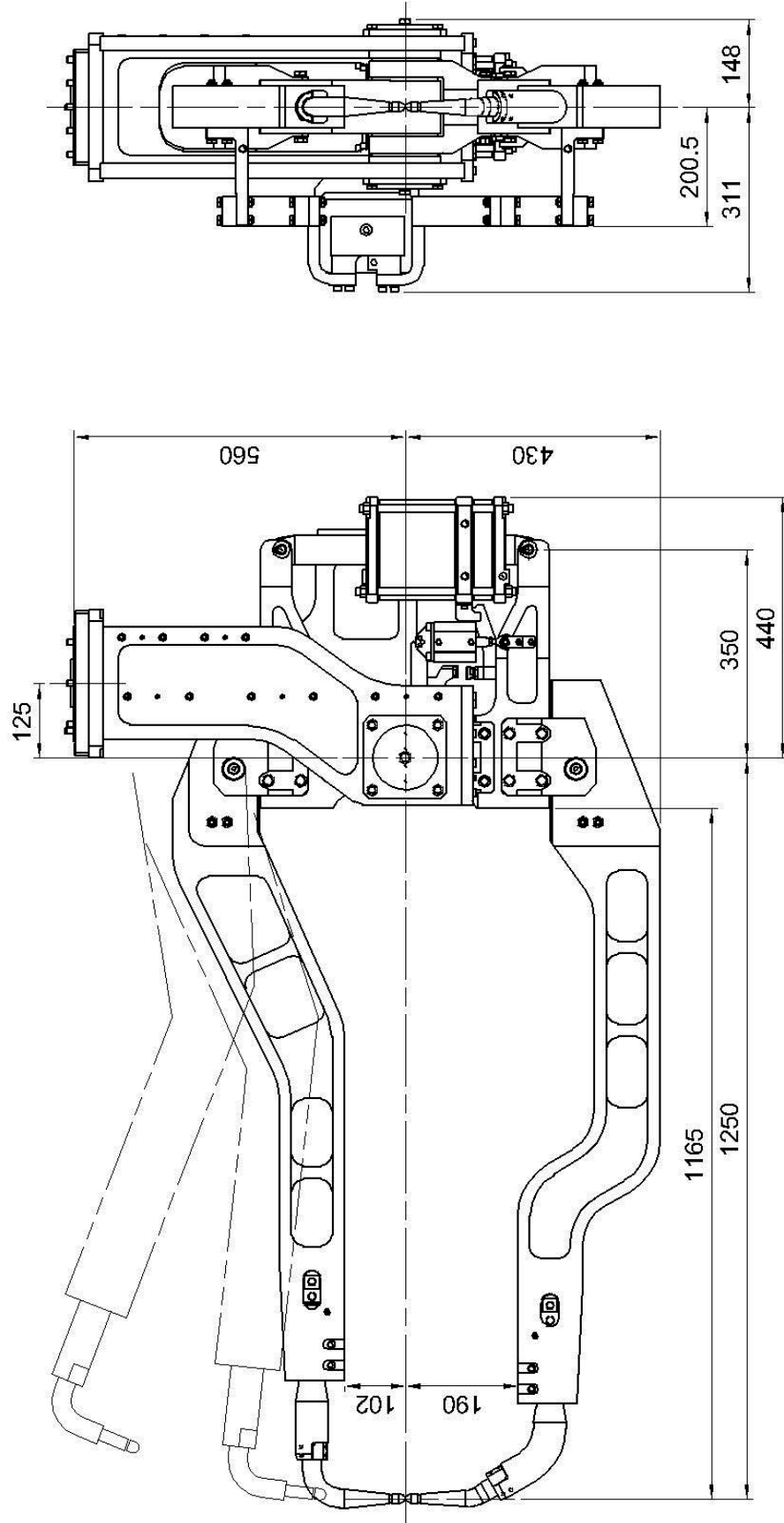

Ce document est la propriété exclusive de la société ALESSIO (I). La reproduction ou l'utilisation de ce document par tiers sans une autorisation écrite de la société est interdite selon les lois CE sur la propriété intellectuelle et le copyright.  
 Questo documento è proprietà esclusiva del Consorzio ALESSIO (I). Ne è pertanto vietata la riproduzione o l'utilizzo con qualsiasi mezzo senza il consenso del consorzio stesso ai sensi delle leggi CE sulla proprietà intellettuale e sul copyright.



This document is exclusive property of ALESSIO (I). Reproduction or use by a third party without written consent of the company is strictly forbidden, according to EC intellectual property and copyright laws.  
Dieses Dokument ist exklusives Eigentum von ALESSIO (I). Reproduktion oder Verwendung durch Dritte ohne schriftliche Zustimmung der Firma ist strikt untersagt, gemäss den EU Gesetzen für Copyrights und geistiges Eigentum.

Carico su elettrodi - Electrode force	Cilindro - Cylinder	Apertura pinza - Gun working stroke	Trasformatore
Carico a 0.1 MPa: Force at 0.1 MPa:	Alesaggio precorsa: Cylinder Dia:	Apertura di saldatura - Welding stroke	-
Carico a di esercizio: Welding force:	Alesaggio saldatura Cylinder Weld Dia:	Braccio superiore Braccio inferiore	Cambio pinza
Carico a consigliato: -:	Corsa avvicinamento: Supplementary stroke: Corsa di saldatura Weld Stroke:	Apertura di svincolo - Supplementary stroke Braccio superiore Braccio inferiore	-
60 daN	160 mm	45 mm	-
- daN a - MPa	160 mm	- mm	-
- daN a - MPa	120 mm	395 mm	-
- daN a - MPa	25 mm	- mm	-

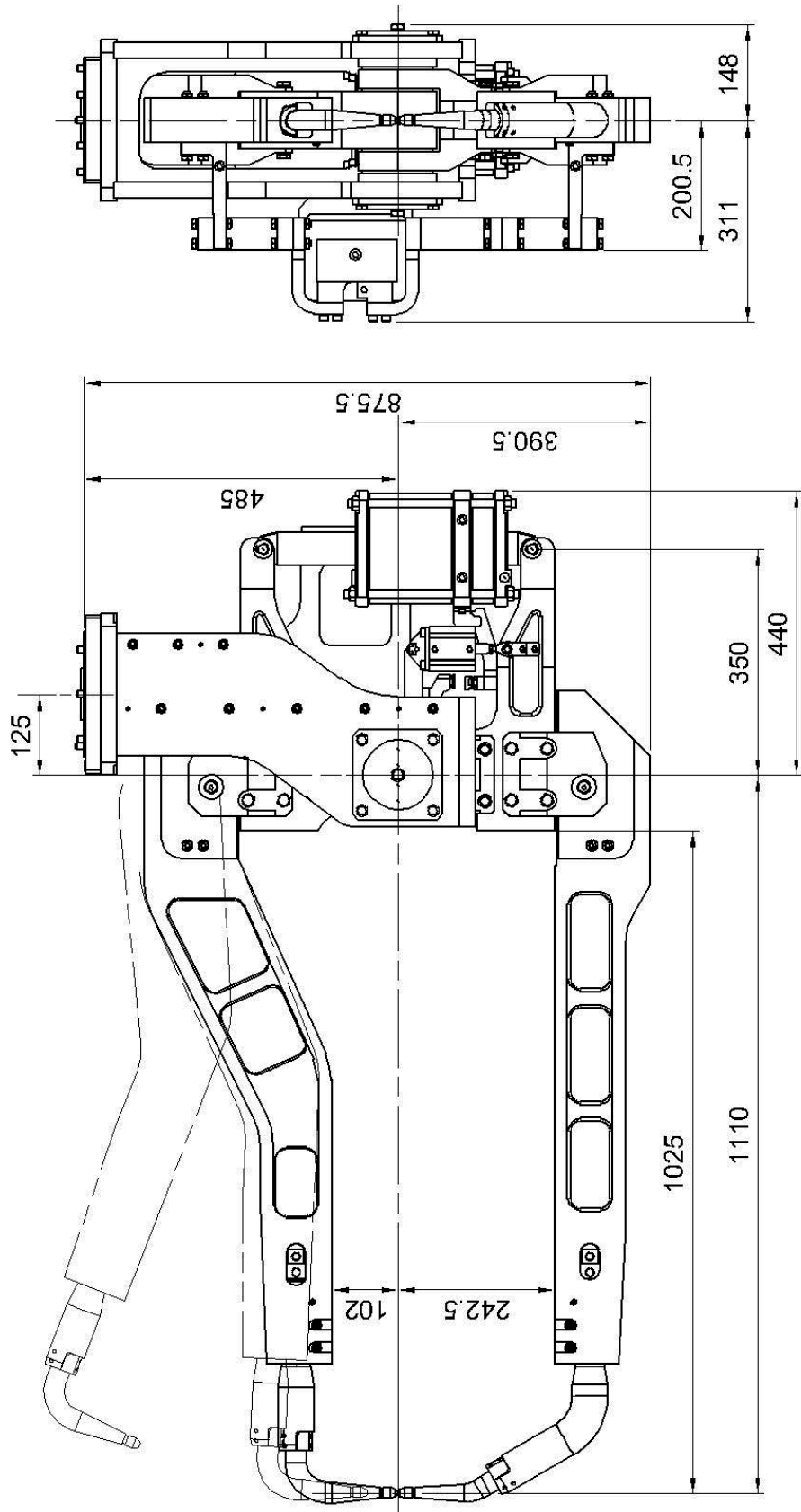

Ce document est la propriété exclusive de la société ALESSIO (I). La reproduction ou l'utilisation de ce document par des tiers sans une autorisation écrite de la société est interdite selon les lois CE sur la propriété intellectuelle et le copyright.  
Questo documento è proprietà esclusiva del Consorzio ALESSIO (I). Ne è pertanto vietata la riproduzione o l'utilizzo con qualsiasi mezzo senza il consenso del consorzio stesso ai sensi delle leggi CE sulla proprietà intellettuale e sul copyright.

This document is exclusive property of ALESSIO (I). Reproduction or use by a third party without written consent of the company is strictly forbidden, according to EC intellectual property and copyright laws.  
 Dieses Dokument ist exklusives Eigentum von ALESSIO (I). Reproduktion oder Verwendung durch Dritte ohne schriftliche Zustimmung der Firma ist strikt untersagt, gemäß den EU Gesetzen für Copyrights und geistiges Eigentum.

Carico su elettrodi - Electrode force	Cilindro - Cylinder	Apertura pinza - Gun working stroke	Trasformatore
Carico a 0.1 MPa: Force at 0.1 MPa:	Alesaggio precorsa: Cylinder Dia:	Apertura di saldatura - Welding stroke	-
Carico a di esercizio: Welding force:	Alesaggio saldatura Cylinder Weld Dia:	Braccio superiore Braccio inferiore	Cambio pinza
Carico a consigliato: -:	Corso avvicinamento: Supplementary stroke: Corso di saldatura Weld Stroke:	Apertura di svincolo - Supplementary stroke Braccio superiore Braccio inferiore	

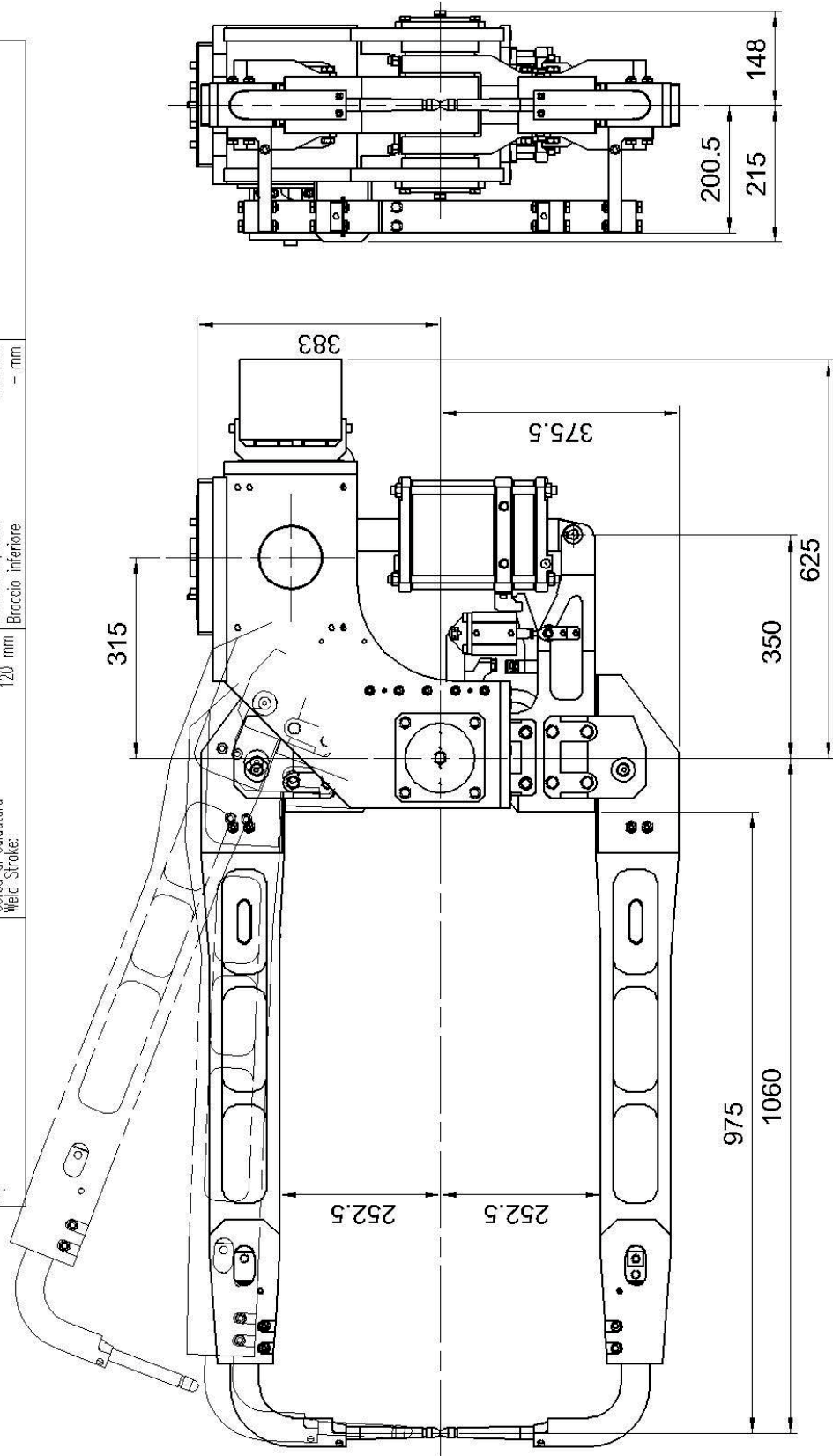

Ce document est la propriété exclusive de la société ALESSIO (I). La reproduction ou l'utilisation de ce document par des tiers sans une autorisation écrite de la société est interdite selon les lois CE sur la propriété intellectuelle et le copyright.  
 Questo documento è proprietà esclusiva del Consorzio ALESSIO (I). Ne è pertanto vietata la riproduzione o l'utilizzo con qualsiasi mezzo senza il consenso del consorzio stesso ai sensi delle leggi CE sulla proprietà intellettuale e sul copyright.

This document is exclusive property of ALESSIO (I). Reproduction or use by a third party without written consent of the company is strictly forbidden, according to EC intellectual property and copyright laws.  
Dieses Dokument ist exklusives Eigentum von ALESSIO (I). Reproduktion oder Verwendung durch Dritte ohne schriftliche Zustimmung der Firma ist strikt untersagt, gemäß den EU Gesetzen für Copyrights und geistiges Eigentum.

Carico su elettrodi - Electrode force	Cilindro - Cylinder	Apertura pinza - Gun working stroke	Trasformatore
Carico a 0,1 MPa: Force at 0,1 MPa:	160 mm	Apertura di saldatura - Welding stroke 45 mm	-
Carico a di esercizio: Welding force:	Alesogio saldatura Cylinder Weld Dia: 160 mm	Braccio superiore Braccio inferiore - mm	Cambio pinza
Carico a consigliato: - MPa	Corso avvicinamento: Supplementary stroke: 25 mm	Apertura di svicolo - Supplementary stroke 378 mm	-
	Corso di saldatura Weld Stroke: 120 mm	Braccio superiore Braccio inferiore - mm	-

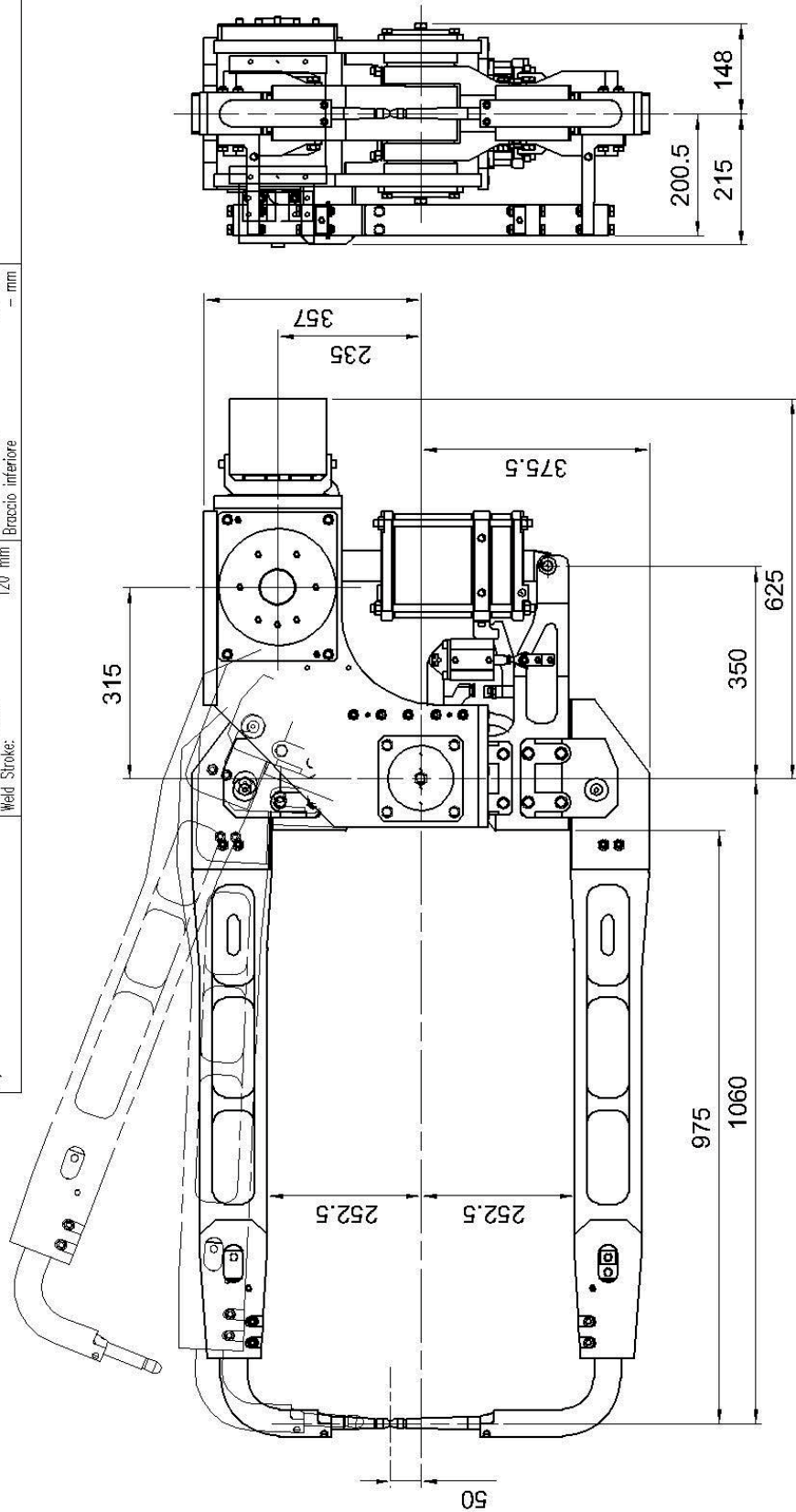

Ce document est la propriété exclusive de la société ALESSIO (I). La reproduction ou l'utilisation de ce document par tiers sans une autorisation écrite de la société est interdite selon les lois CE sur la propriété intellectuelle et le copyright.  
Questo documento è proprietà esclusiva del Consorzio ALESSIO (I). Ne è pertanto vietata la riproduzione o l'utilizzo con qualsiasi mezzo senza il consenso del consorzio stesso ai sensi delle leggi CE sulla proprietà intellettuale e sul copyright.



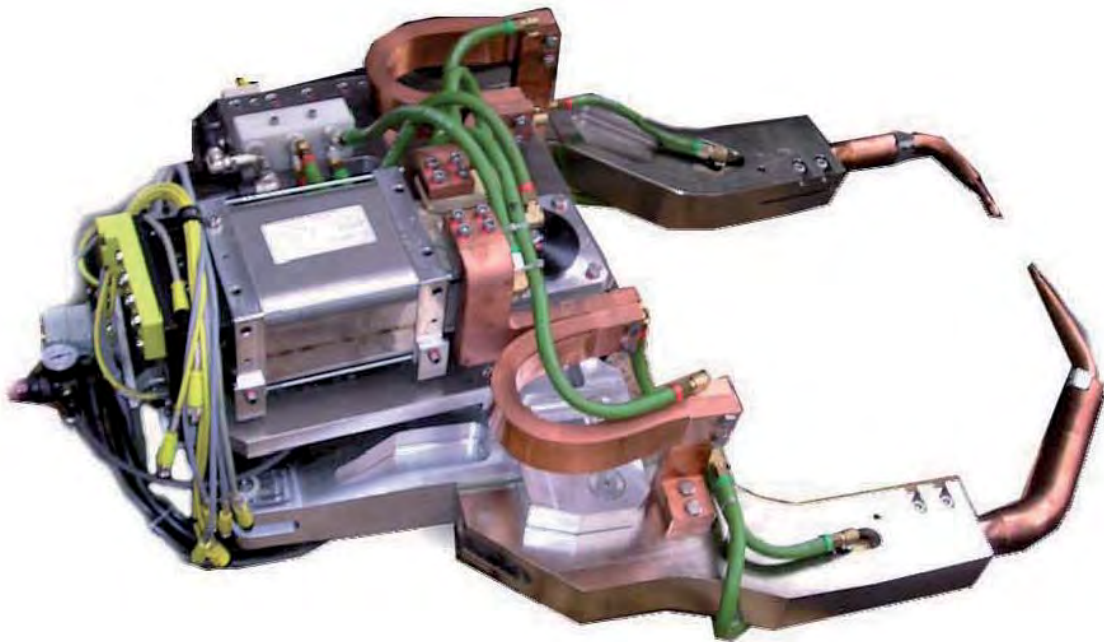
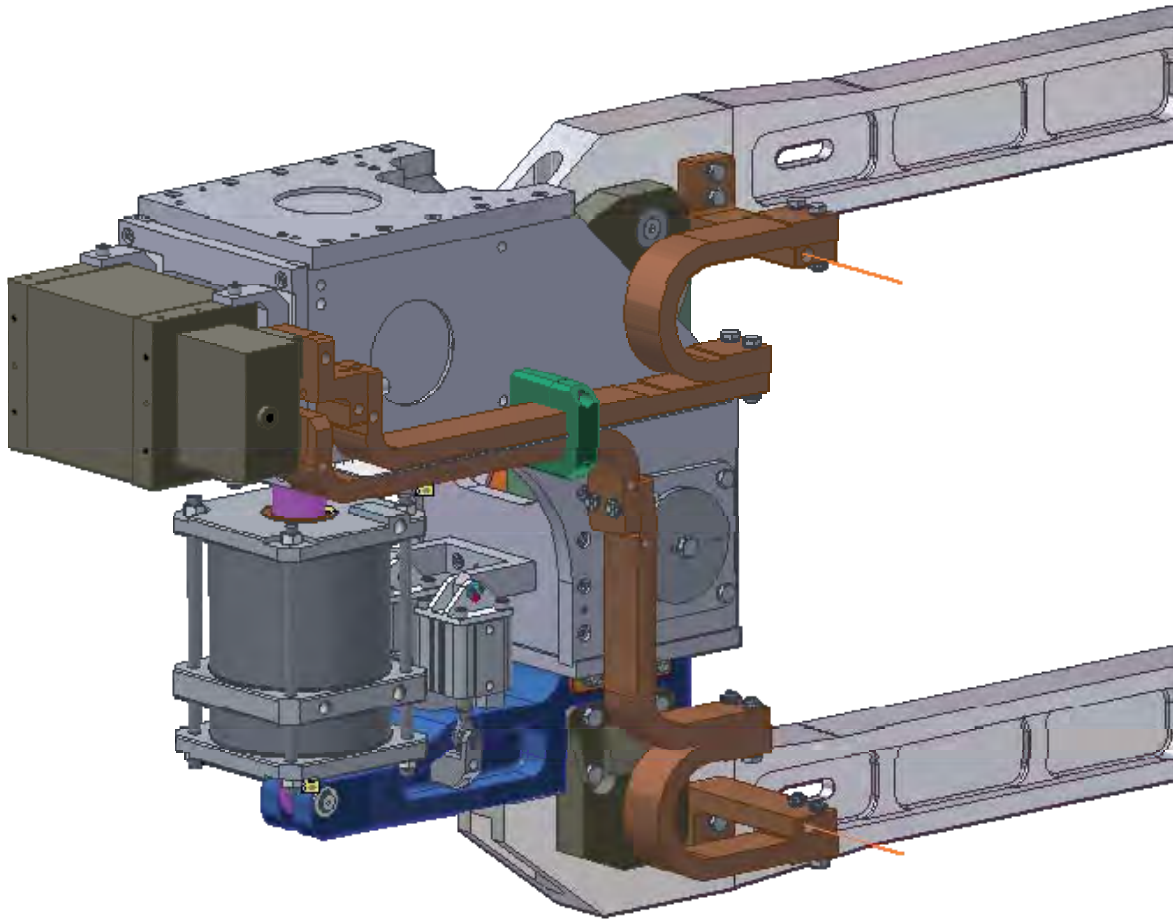

This document is exclusive property of ALESSIO (I). Reproduction or use by a third party without written consent of the company is strictly forbidden, according to EC intellectual property and copyright laws.  
Dieses Dokument ist exklusives Eigentum von ALESSIO (I). Reproduktion oder Verwendung durch Dritte ohne schriftliche Zustimmung der Firma ist strikt untersagt, gemäß den EU-Gesetzen für Copyrights und geistiges Eigentum.

Ce document est la propriété exclusive de la société ALESSIO (I). La reproduction ou l'utilisation de ce document par des tiers sans une autorisation écrite de la société est interdite selon les lois CE sur la propriété intellectuelle et le copyright.  
Questo documento è proprietà esclusiva del Consorzio ALESSIO (I). Ne è pertanto vietata la riproduzione o l'utilizzo con qualsiasi mezzo senza il consenso del consorzio stesso ai sensi delle leggi CE sulla proprietà intellettuale e sul copyright.

# Technical details of design concept and manufacturing process

This document is exclusive property of ALESSIO (I). Reproduction or use by a third party without written consent of the company is strictly forbidden, according to EC intellectual property and copyright laws.  
Dieses Dokument ist exklusives Eigentum von ALESSIO (I). Reproduktion oder Verwendung durch Dritte ohne schriftliche Zustimmung der Firma ist strikt untersagt, gemäß den EU Gesetzen für Copyrights und geistiges Eigentum.

Ce document est la propriété exclusive de la société ALESSIO (I). La reproduction ou l'utilisation de ce document par des tiers sans une autorisation écrite de la société est interdite selon les lois CE sur la propriété intellectuelle et le copyright.  
Questo documento è proprietà esclusiva del Consorzio ALESSIO (I). Ne è pertanto vietata la riproduzione o l'utilizzo con qualsiasi mezzo senza il consenso del consorzio stesso ai sensi delle leggi CE sulla proprietà intellettuale e sul copyright.

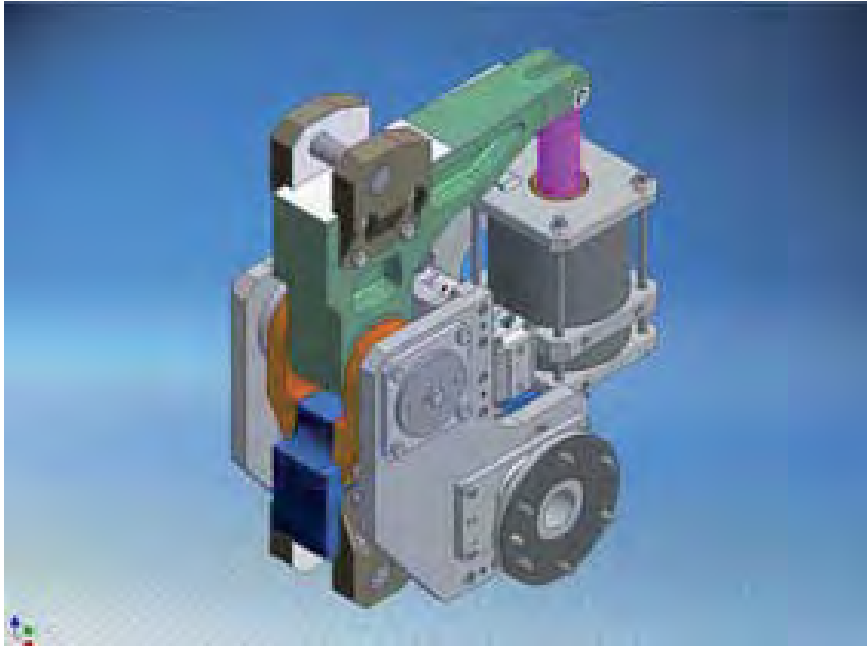

View of the standard gun body coupled with a mounting for fixing the gun to the robot sidewise.

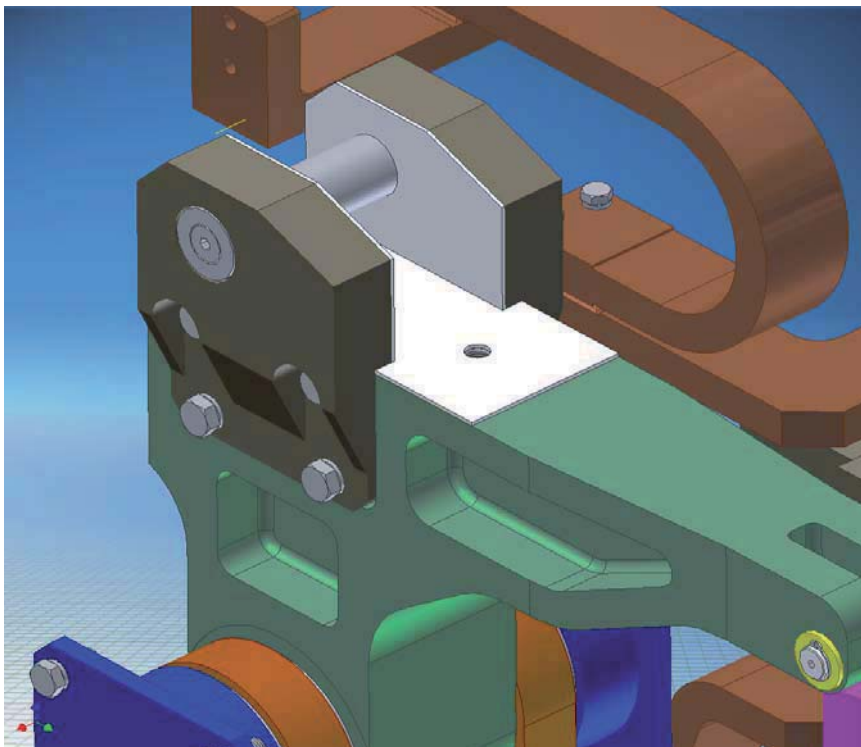

Each of the arm-holders centres and keeps the arm tightly:

- a) by a 32mm reaction rod
- b) by a large reaction plane
- c) by an adjustable pressing screw with counter-nuts to avoid backlash



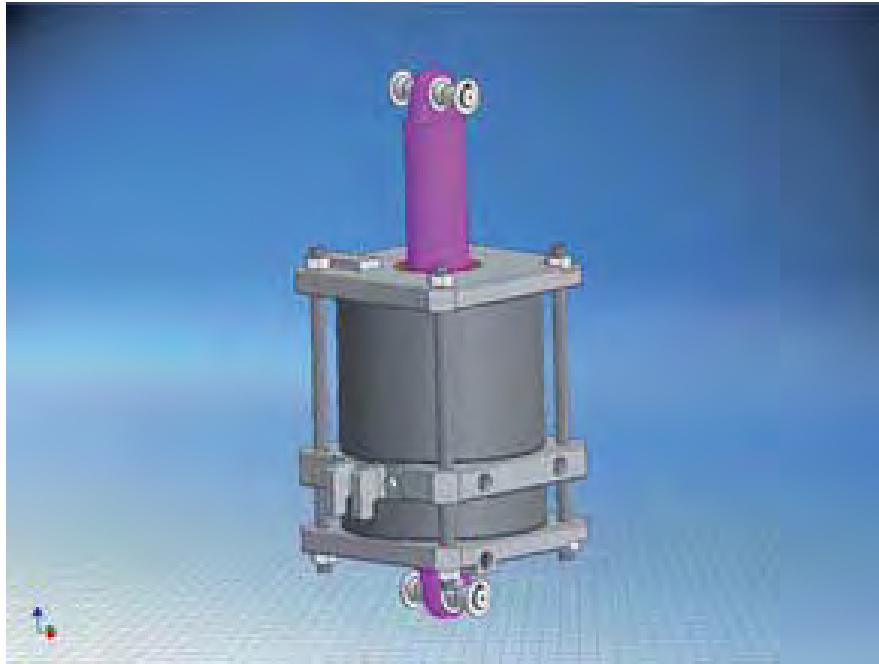

**WELD CYLINDER:**

One type of weld cylinder is foreseen, dia. 160mm (Weld Force = 196daN x bar)

The total stroke is 135 mm (weld stroke + pre-stroke).

Strokes can be varied by adding internal spacers.

Usually a pre-stroke up to 120 mm and a weld stroke of 15 mm are used (+ 10mm stroke for burn-off)

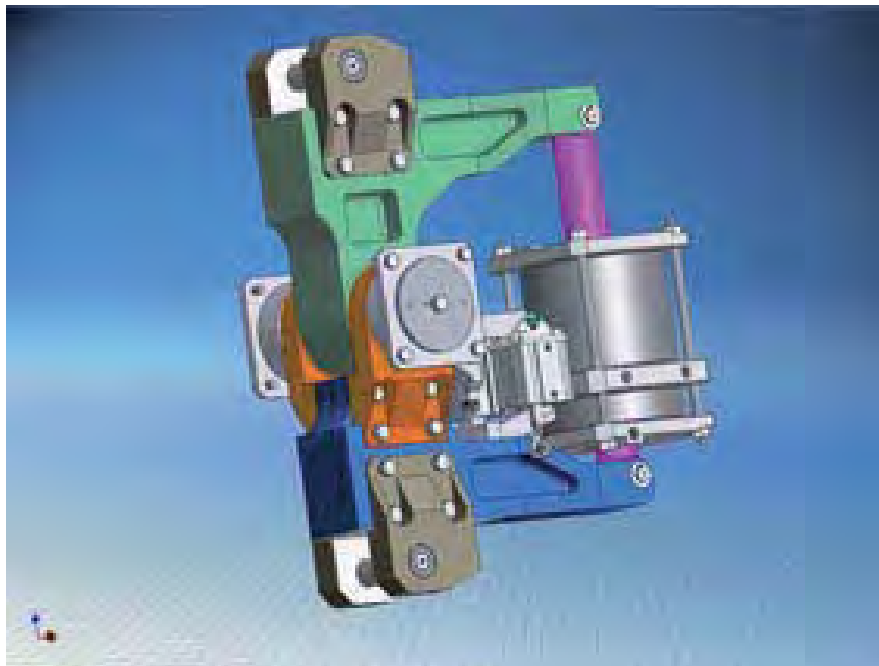

View of the gun body in its standard version, without mountings and arms.

# Weld Cylinder

Standard Strokes:

Approach ....125 mm  
Weld ..... 25 mm

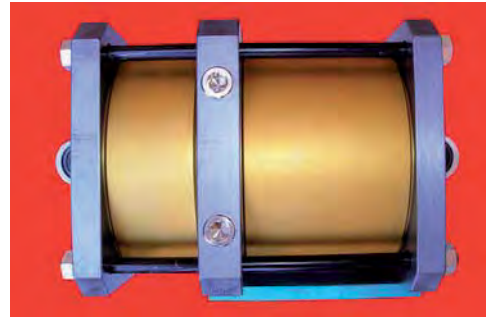

This document is exclusive property of ALESSIO (I). Reproduction or use by a third party without written consent of the company is strictly forbidden, according to EC intellectual property and copyright laws.  
Dieses Dokument ist exclusives Eigentum von ALESSIO (I). Reproduktion oder Verwendung durch Dritte ohne schriftliche Zustimmung der Firma ist strikt untersagt, gemäss den EU Gesetzen für Copyrights und geistiges Eigentum.

Ce document est la propriété exclusive de la société ALESSIO (I). La reproduction ou l'utilisation de ce document par des tiers sans une autorisation écrite de la société est interdite selon les lois CE sur la propriété intellectuelle et le copyright.  
Questo documento è proprietà esclusiva del Consorzio ALESSIO (I). Ne è pertanto vietata la riproduzione o l'utilizzo con qualsiasi mezzo senza il consenso del consorzio stesso ai sensi delle leggi CE sulla proprietà intellettuale e sul copyright.

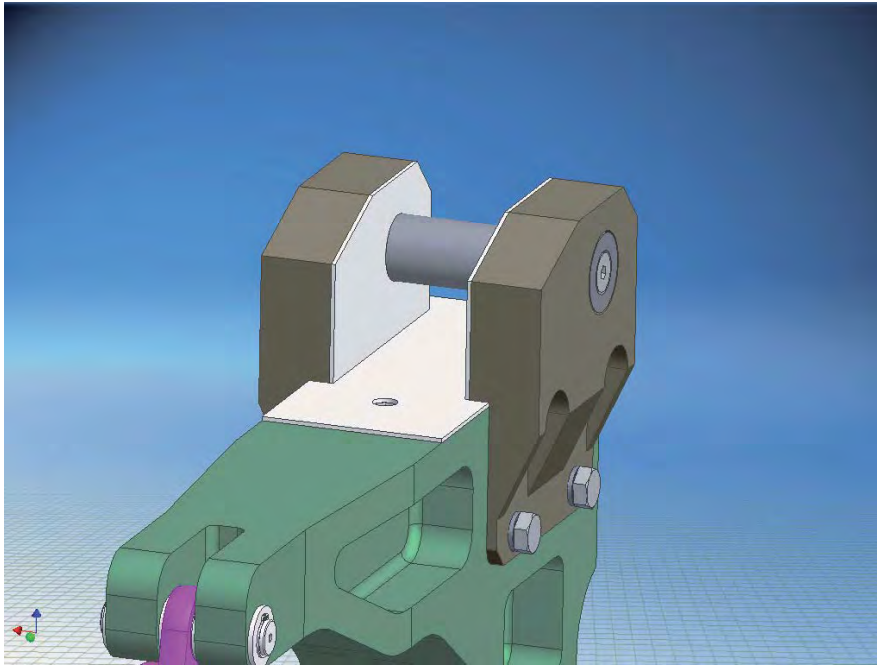

Detail of the arm holder showing the insulation of the arm from gun body (white plates in Vetronyte).

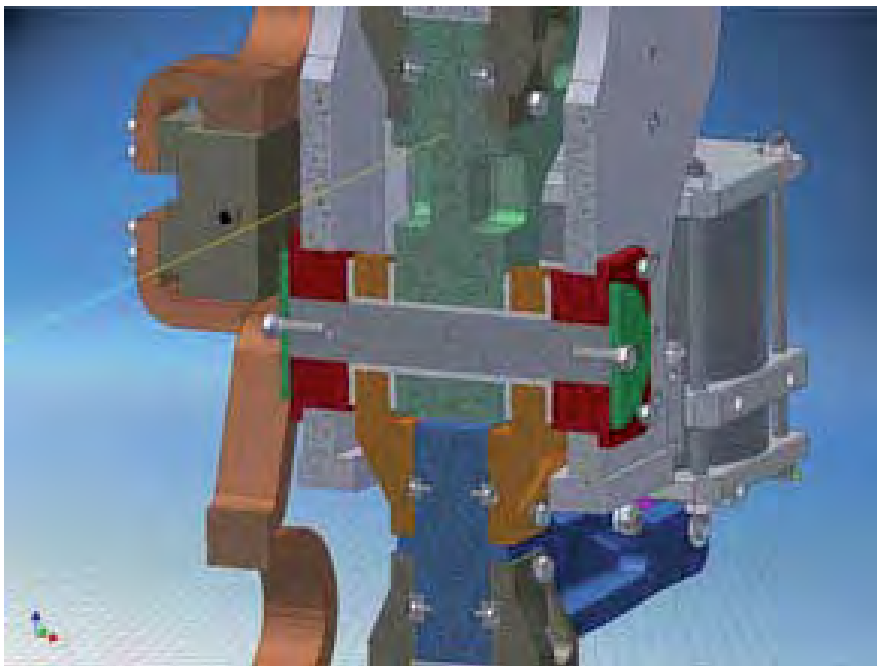

Cross section of the pivoting centre and of its connection to other components. This assembly is the same for LH and RH versions of the guns. Busbars are kept very close to gun body for minimum bulk.



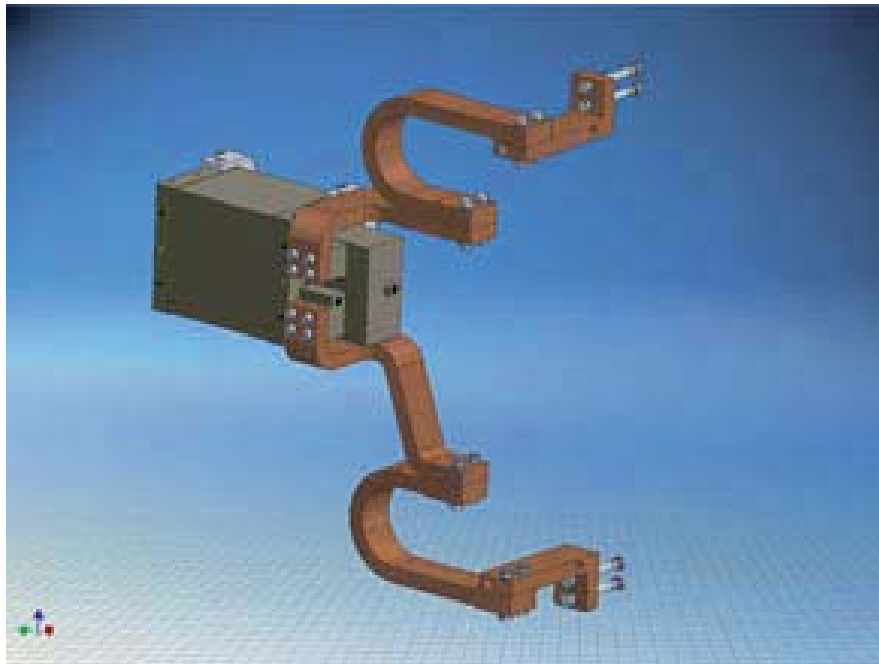

For any secondary area, busbars and shunts from TR to the arms are the same for all gun configurations.  
For these large gun types, only MF transformers are foreseen.  
As far as secondary circuit, LH & RH versions differ only for the two busbars From TR to shunts.  
Heating of busbars is reduced to minimum as large cross-sections are used (1000 mm<sup>2</sup>)

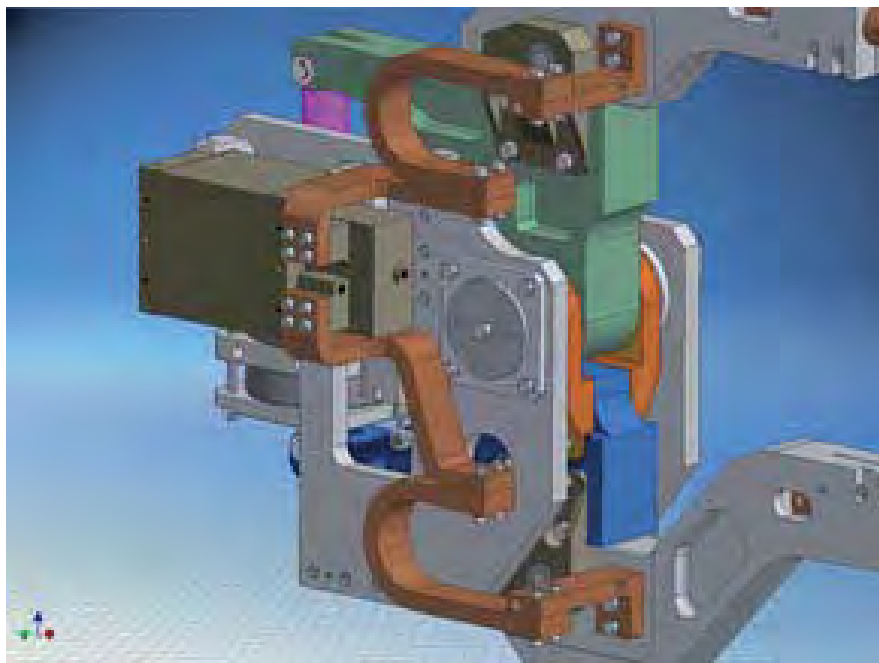

View of the secondary circuit inserted in the gun.

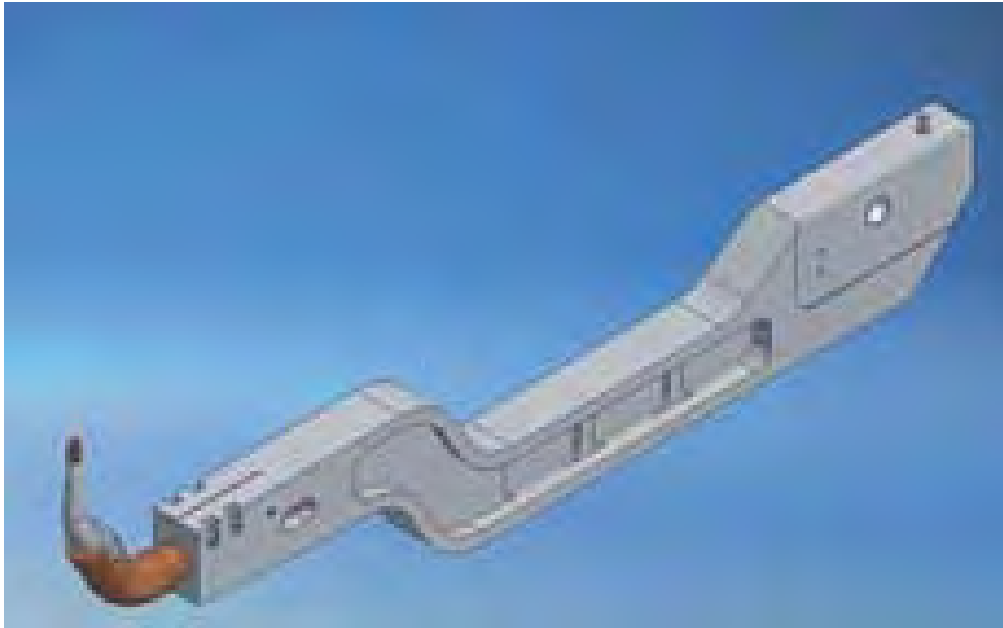

All arms are made in high resistance Al alloy (see page 13).  
 NO castings are used. All arms are machined directly from plates, then Nickel-plated.  
 In the areas in which they are in contact with Copper components bringing the weld current they are silver-plated.  
 The arms and the electrode holders are the only specific components in a new gun configuration.  
 The two ends of the arms are always constant and machining programs are pre-defined to be coupled to those for machining the variable shape of arms.

All socket head screws needing an insulation are inserted in bushes covering head and stem of the screw.  
 A stainless steel washer is encapsulated in the bush to distribute pressure in the insulating material in the most uniform way.

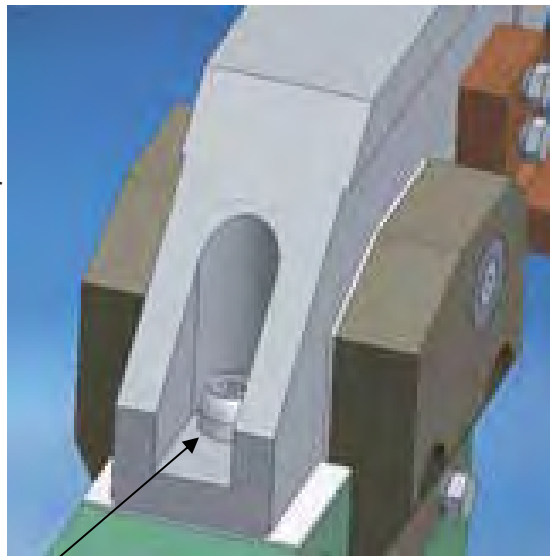

B

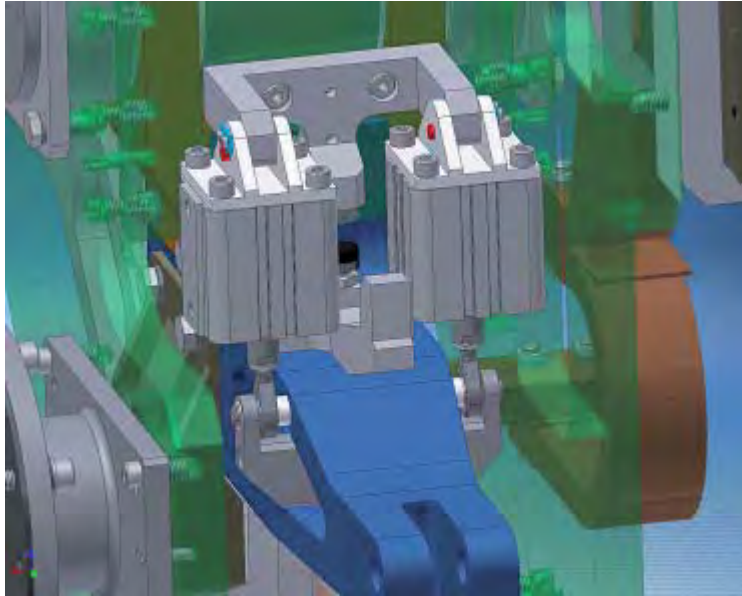

### BALANCE CYLINDERS

Two balance cylinders are fitted to the gun.  
 Each cylinder is 50mm dia. and 25 mm. stroke.  
 The total balancing force generated is 39.25kg x bar.  
 At 5.5 bar the balancing force is 217kg.

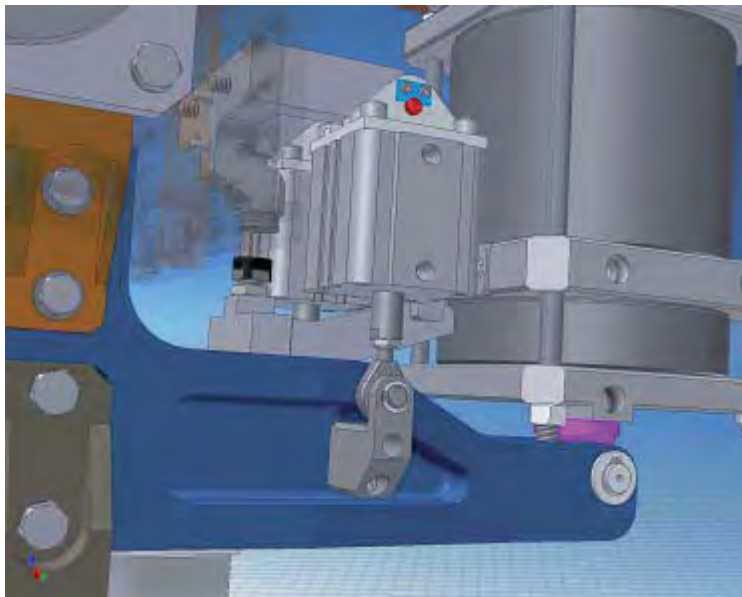

### STOP BRACKET.

The stop against which the 2 balance cylinders push the gun body after a spot-weld is adjustable by a threaded rod with counter-nut. Both cylinders exert their force on the same stop, through a bifurcated bracket positioned in the centre.



## All gun bolts submitted to fatigue stress are self-locking

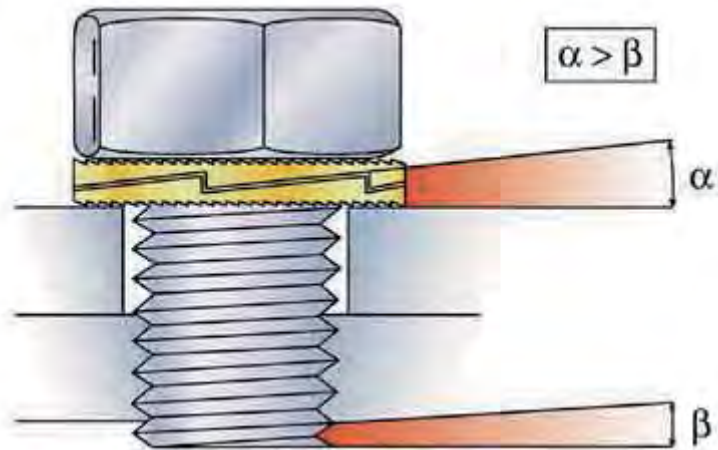

The key is the difference in angles. Since the angle "  $\alpha$  " is larger than the angle "  $\beta$  ", the pair of washers expand more than the corresponding pitch of the thread. Nord-Lock® washers positively lock the fastener in a joint which is subjected to extreme vibration or dynamic loads.

### Locking function

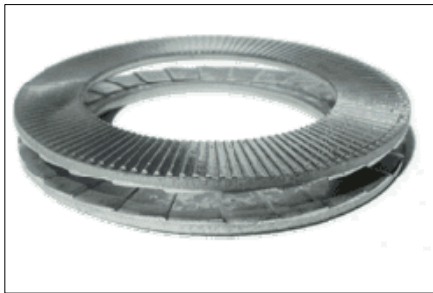

Nord-Lock® is a pair of washers with a wedge-locking action meeting DIN 25201 which is a unique method using tension instead of friction.

The rise of the cams between the Nord-Lock® washers is greater than the pitch of the bolt. In addition, there are adial teeth on the opposite side. The washers are installed in pairs, cam face to cam face.

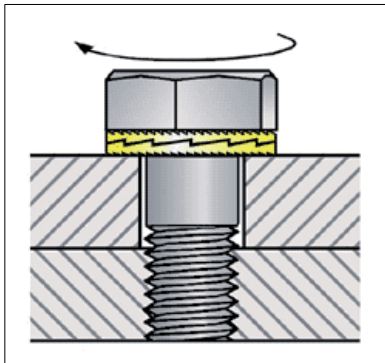

When the bolt and/or nut is tightened the teeth grip and seat the mating surfaces. The Nord-Lock® washer is locked in place, allowing movement only across the face of the cams.

Any attempt from the bolt/nut to rotate loose is blocked by the wedge effect of the cams.

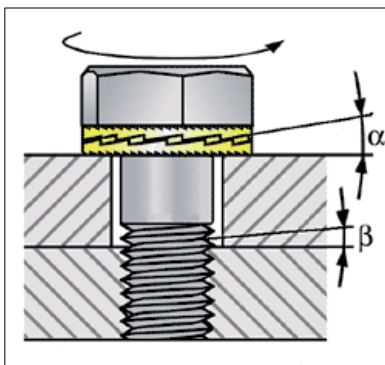

Here you see what happens when a bolt is untightened with a wrench. The pair of washers expand more than the corresponding pitch of the thread allows the bolt/nut to rise.

Nord-Lock® washers positively lock the fastener in a joint which is subjected to any kind of vibration or dynamic loads.

## Components in Al alloy

In this type of guns the components made in Al alloy represent more than 70% in quantity and more than 50% in weight.

No cast component is used.

All components are machined directly from plates.

From each plate one or more components can be made, according to their shape, with CAM programs to minimize material waste.

The surface of raw material is already finished.

The alloy is EN-AW 7075 T651 (EN AW-Al Zn5,5MgCu)

The chemical and mechanical characteristics of the alloy are the following:

### **Chemical composition:**

Si 0,40 %

Fe 0,50 %

Cu 1,2-2 %

Mn 0,3 %

Mg 2,1-2,9 %

Cr 0,18-0,28 %

Zn 5,1-6,1 %

Ti 0,20%

Others: 0,05% each element for a total of 0,15%)

Rest: Al (87,17-89,87%)

### **Mechanical and electrical characteristics:**

Hardness: 147-161 HBS

Tensile stress: min 49-54 kg/mm<sup>2</sup>

Yield point: 39-47 kg/mm<sup>2</sup>

Electrical conductivity: >22MS/m

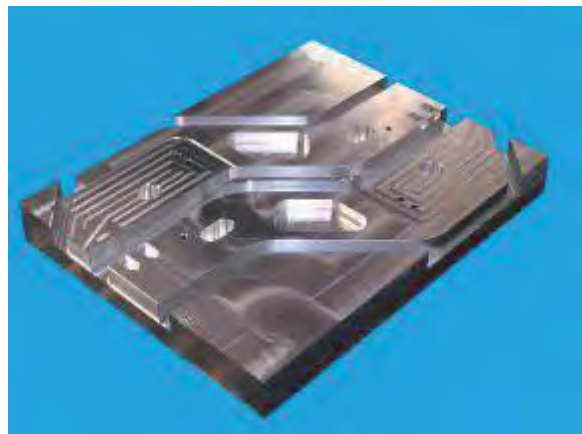
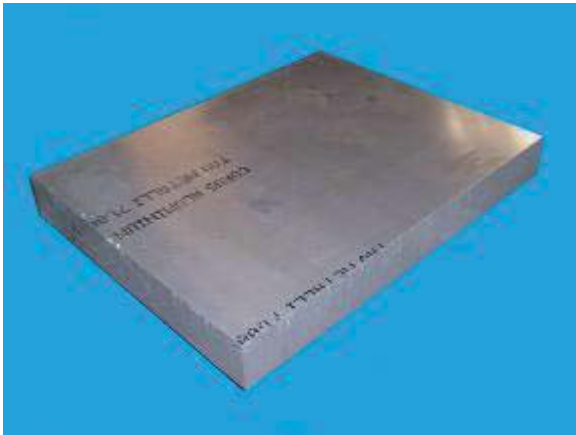



## Different phases of machining components from plates

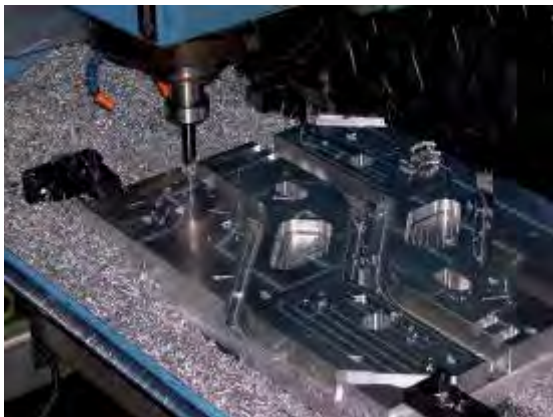
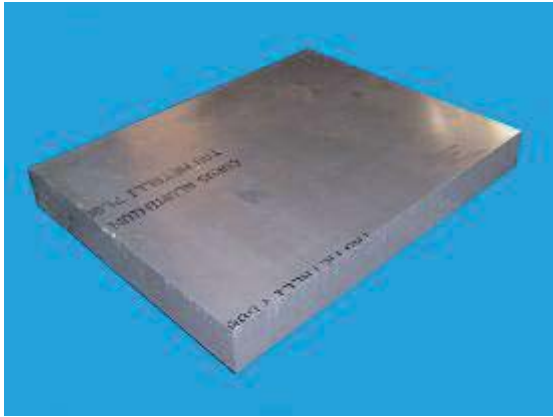

This document is exclusive property of ALESSIO (I). Reproduction or use by a third party without written consent of the company is strictly forbidden, according to EC intellectual property and copyright laws. Dieses Dokument ist exklusives Eigentum von ALESSIO (I). Reproduktion oder Verwendung durch Dritte ohne schriftliche Zustimmung der Firma ist strikt untersagt, gemäß den EU Gesetzen für Copyrights und geistiges Eigentum.

Ce document est la propriété exclusive de la société ALESSIO (I). La reproduction ou l'utilisation de ce document par des tiers sans une autorisation écrite de la société est interdite selon les lois CE sur la propriété intellectuelle et le copyright. Questo documento è proprietà esclusiva del Consorzio ALESSIO (I). Ne è pertanto vietata la riproduzione o l'utilizzo con qualsiasi mezzo senza il consenso del consorzio stesso ai sensi delle leggi CE sulla proprietà intellettuale e sul copyright.



## No cast components. Only parts from plates

This new range of guns use plates of high resistance Al alloy.  
Their tensile strength is  $> 50 \text{ kg/mm}^2$ .

Parts are CAM machined and programs are standardized.

Variables for specific gun configurations involve  $< 30\%$  change in machining programs.

200 kg of raw Al material for 80kg of finished high-resistance components

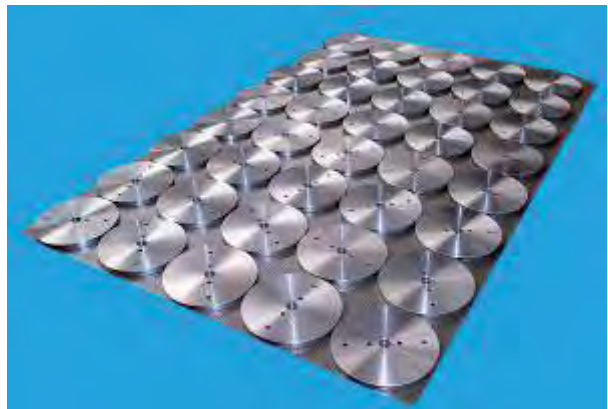
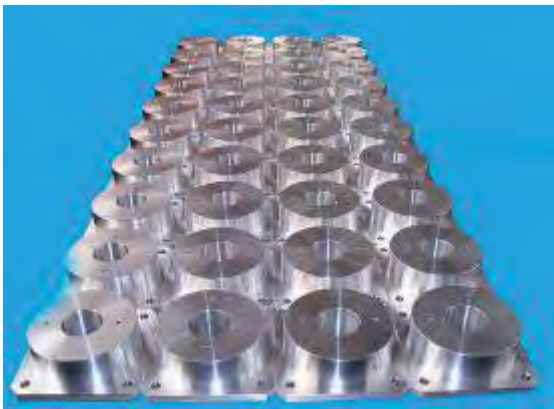
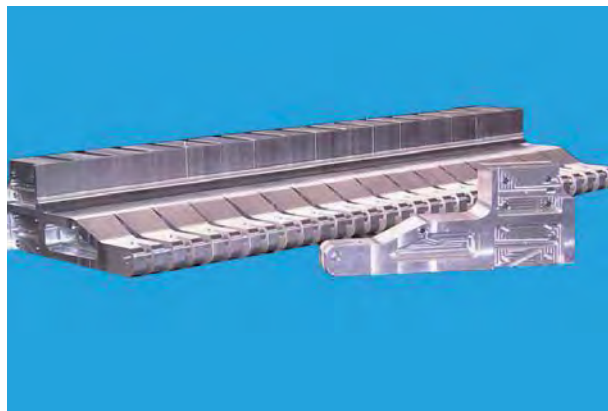

This document is exclusive property of ALESSIO (I). Reproduction or use by a third party without written consent of the company is strictly forbidden, according to EC intellectual property and copyright laws.  
Dieses Dokument ist exklusives Eigentum von ALESSIO (I). Reproduktion oder Verwendung durch Dritte ohne schriftliche Zustimmung der Firma ist strikt untersagt, gemäß den EU Gesetzen für Copyrights und geistiges Eigentum.

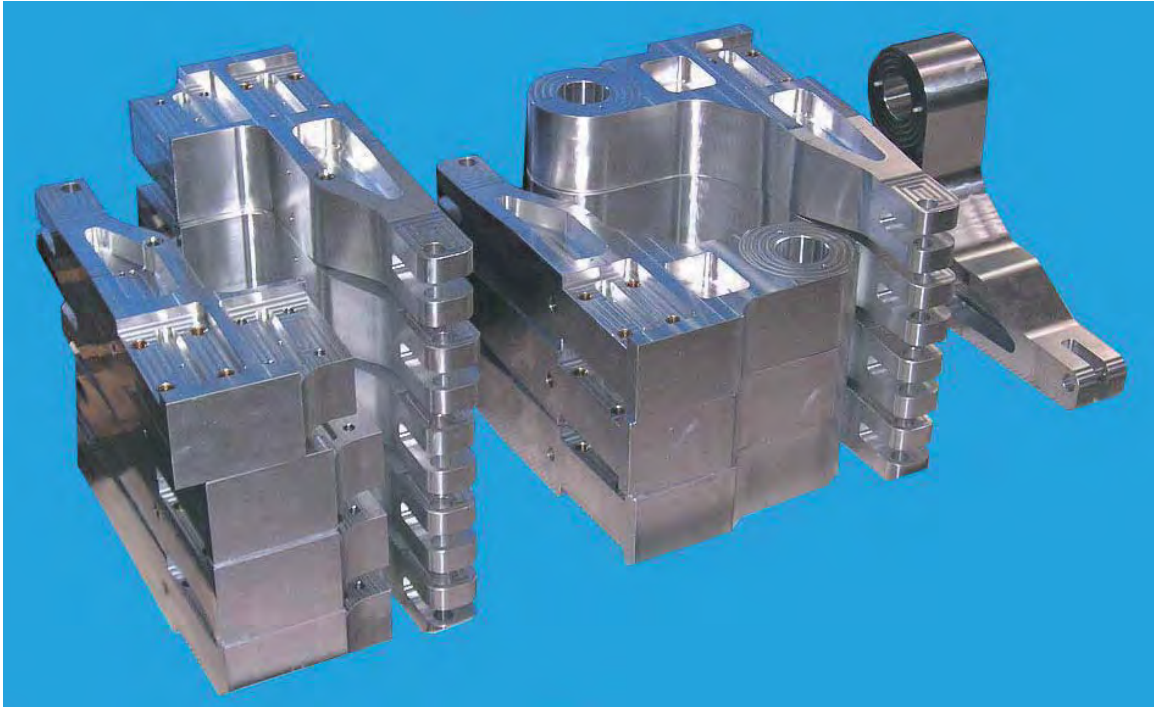

Ce document est la propriété exclusive de la société ALESSIO (I). La reproduction ou l'utilisation de ce document par des tiers sans une autorisation écrite de la société est interdite selon les lois CE sur la propriété intellectuelle et le copyright.  
Questo documento è proprietà esclusiva del Consorzio ALESSIO (I). Ne è pertanto vietata la riproduzione o l'utilizzo con qualsiasi mezzo senza il consenso del consorzio stesso ai sensi delle leggi CE sulla proprietà intellettuale e sul copyright.

# Optimisation of costs by producing in batches

This document is exclusive property of ALESSIO (I). Reproduction or use by a third party without written consent if the company is strictly forbidden, according to EC intellectual property and copyright laws.  
Dieses Dokument ist exklusives Eigentum von ALESSIO (I). Reproduktion oder Verwendung durch Dritte ohne schriftliche Zustimmung der Firma ist strikt untersagt, gemäß den EU Gesetzen für Copyrights und geistiges Eigentum.

Ce document est la propriété exclusive de la société ALESSIO (I). La reproduction ou l'utilisation de ce document par des tiers sans une autorisation écrite de la société est interdite selon les lois CE sur la propriété intellectuelle et le copyright.  
Questo documento è proprietà esclusiva del Consorzio ALESSIO (I). Ne è pertanto vietata la riproduzione o l'utilizzo con qualsiasi mezzo senza il consenso del consorzio stesso ai sensi delle leggi CE sulla proprietà intellettuale e sul copyright.



## Optimizing costs by producing batches of 20 units

It is always difficult to predict quantities when producing large robot guns.

This range of guns has been designed to knock down the quantity of special components to less than 15%

In fact:

- 1) the body is common for all gun configurations
- 2) Each gun is made of 100 components, of which:
  - 42 major components and 43 minor ones are standard
  - 14 other components only are specific to the gun configuration

This range of guns allows then:

- to manufacturer to produce in small batches, optimize costs, keep a stock of standard components and offer faster delivery terms and better prices
- to the customer to have the minimum risk for special design guns, and the minimum stock of spares for the max. quantity of guns.

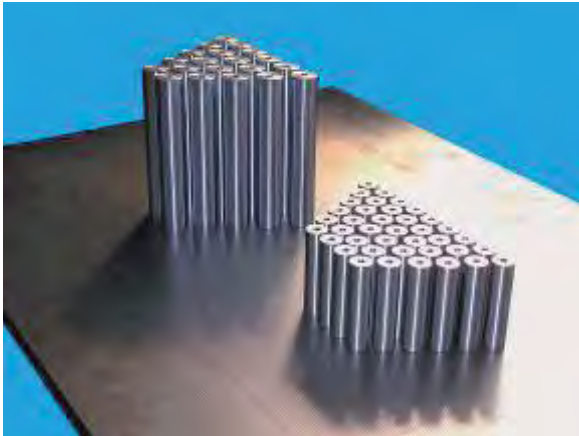

This document is exclusive property of ALESSIO (I). Reproduction or use by a third party without written consent of the company is strictly forbidden, according to EC intellectual property and copyright laws.  
Dieses Dokument ist exklusives Eigentum von ALESSIO (I). Reproduktion oder Verwendung durch Dritte ohne schriftliche Zustimmung der Firma ist strikt untersagt, gemäß den EU Gesetzen für Copyrights und geistiges Eigentum.



Ce document est la propriété exclusive de la société ALESSIO (I). La reproduction ou l'utilisation de ce document par des tiers sans une autorisation écrite de la société est interdite selon les lois CE sur la propriété intellectuelle et le copyright.  
Questo documento è proprietà esclusiva del Consorzio ALESSIO (I). Ne è pertanto vietata la riproduzione o l'utilizzo con qualsiasi mezzo senza il consenso del consorzio stesso ai sensi delle leggi CE sulla proprietà intellettuale e sul copyright.



This document is exclusive property of ALESSIO (I). Reproduction or use by a third party without written consent of the company is strictly forbidden, according to EC intellectual property and copyright laws.  
Dieses Dokument ist exklusives Eigentum von ALESSIO (I). Reproduktion oder Verwendung durch Dritte ohne schriftliche Zustimmung der Firma ist strikt untersagt, gemäß den EU Gesetzen für Copyrights und geistiges Eigentum.

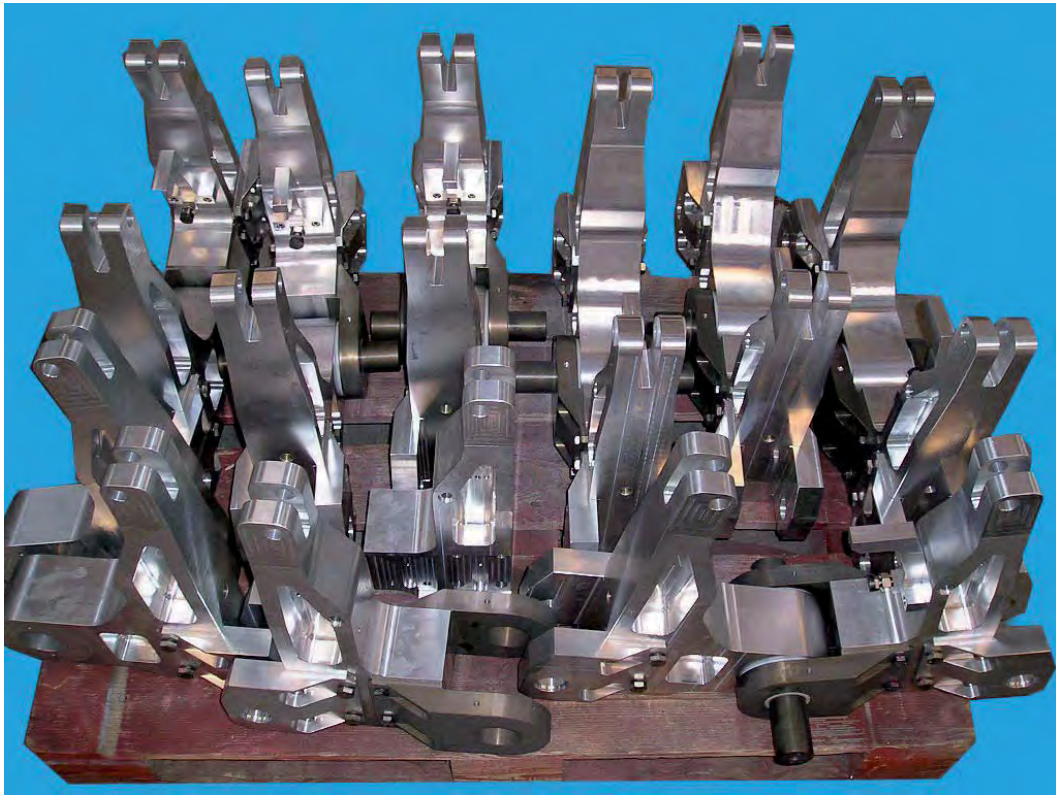
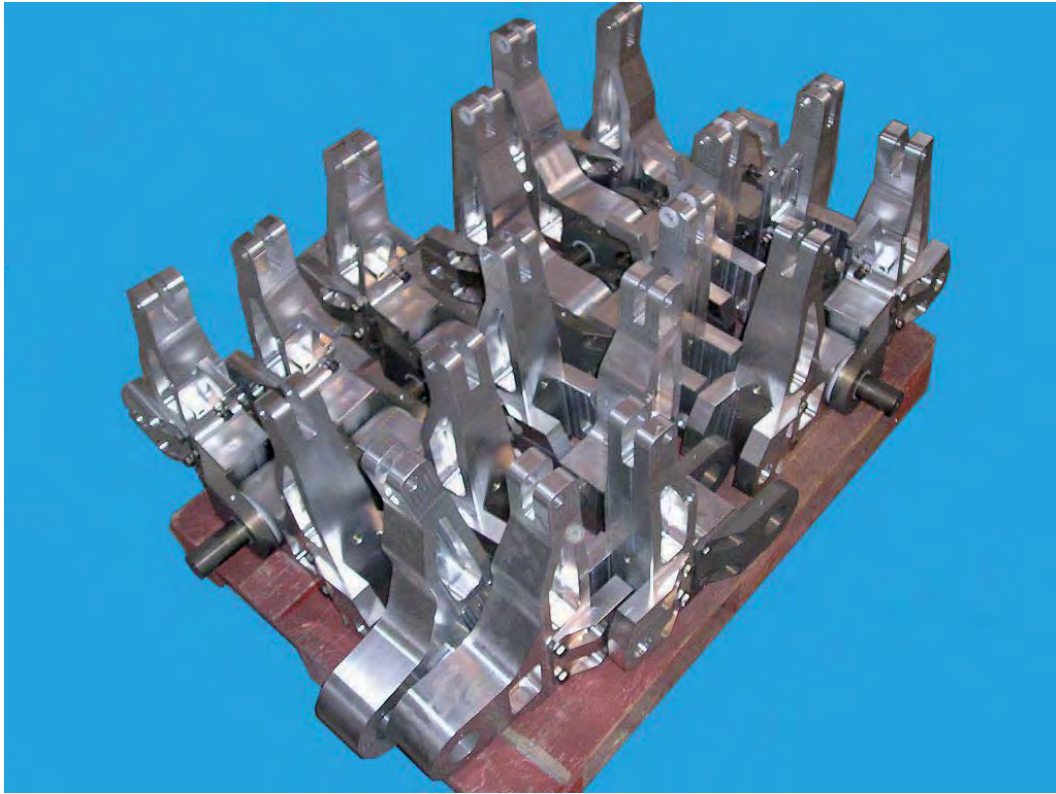

Ce document est la propriété exclusive de la société ALESSIO (I). La reproduction ou l'utilisation de ce document par des tiers sans une autorisation écrite de la société est interdite selon les lois CE sur la propriété intellectuelle et le copyright.  
Questo documento è proprietà esclusiva del Consorzio ALESSIO (I). Ne è pertanto vietata la riproduzione o l'utilizzo con qualsiasi mezzo senza il consenso del consorzio stesso ai sensi delle leggi CE sulla proprietà intellettuale e sul copyright.



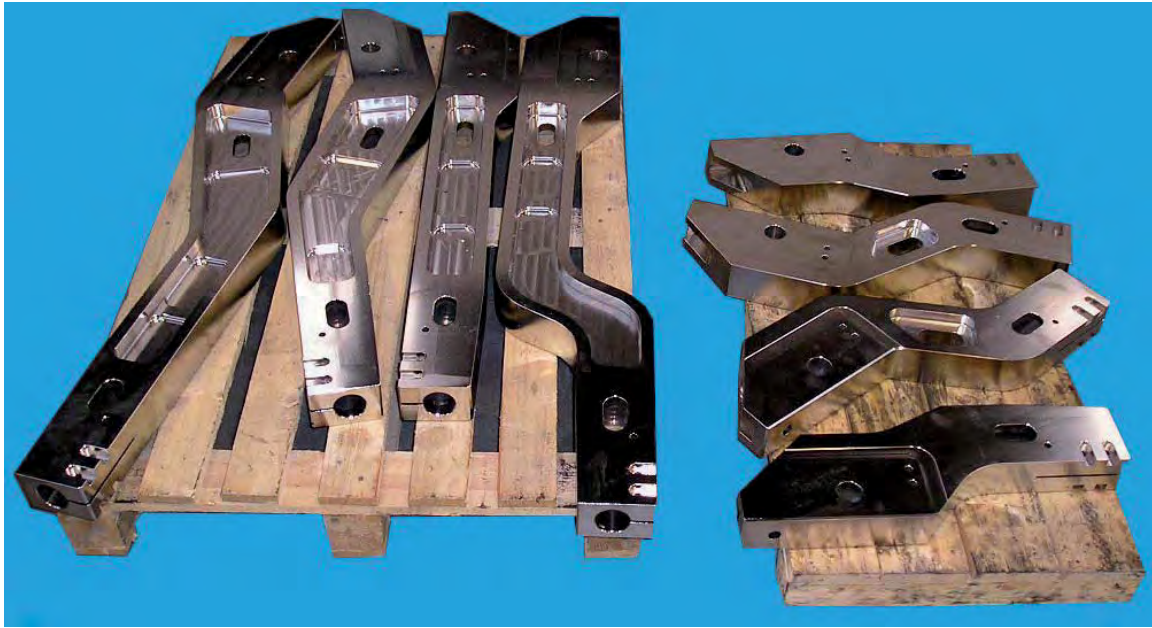

This document is exclusive property of ALESSIO (I). Reproduction or use by a third party without written consent of the company is strictly forbidden, according to EC intellectual property and copyright laws. Dieses Dokument ist exklusives Eigentum von ALESSIO (I). Reproduktion oder Verwendung durch Dritte ohne schriftliche Zustimmung der Firma ist strikt untersagt, gemäß den EU-Gesetzen für Copyrights und geistiges Eigentum.

Ce document est la propriété exclusive de la société ALESSIO (I). La reproduction ou l'utilisation de ce document par des tiers sans une autorisation écrite de la société est interdite selon les lois CE sur la propriété intellectuelle et le copyright. Questo documento è proprietà esclusiva del Consorzio ALESSIO (I). Ne è pertanto vietata la riproduzione o l'utilizzo con qualsiasi mezzo senza il consenso del consorzio stesso ai sensi della legge CE sulla proprietà intellettuale e sul copyright.

This document is exclusive property of ALESSIO (I). Reproduction or use by a third party without written consent if the company is strictly forbidden, according to EC intellectual property and copyright laws.  
Dieses Dokument ist exklusives Eigentum von ALESSIO (I). Reproduktion oder Verwendung durch Dritte ohne schriftliche Zustimmung der Firma ist strikt untersagt, gemäss den EU Gesetzen für Copyrights und geistiges Eigentum.



Ce document est la propriété exclusive de la société ALESSIO (I). La reproduction ou l'utilisation de ce document par des tiers sans une autorisation écrite de la société est interdite selon les lois CE sur la propriété intellectuelle et le copyright.  
Questo documento è proprietà esclusiva del Consorzio ALESSIO (I). Ne è pertanto vietata la riproduzione o l'utilizzo con qualsiasi mezzo senza il consenso del consorzio stesso ai sensi delle leggi CE sulla proprietà intellettuale e sul copyright.



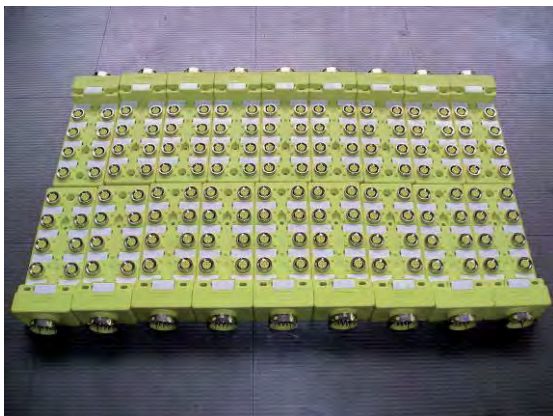
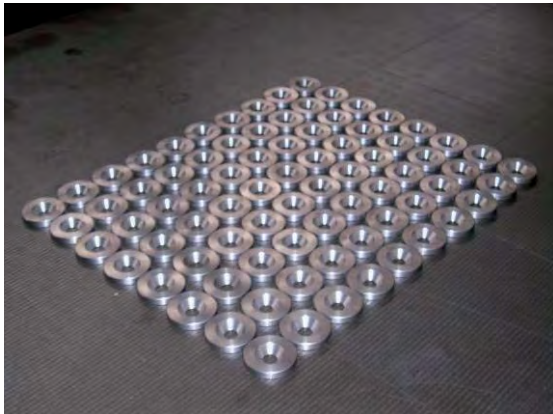
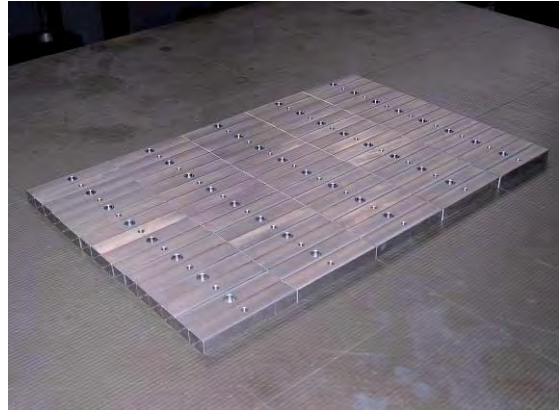

This document is exclusive property of ALESSIO (I). Reproduction or use by a third party without written consent of the company is strictly forbidden, according to EC intellectual property and copyright laws. Dieses Dokument ist exklusives Eigentum von ALESSIO (I). Reproduktion oder Verwendung durch Dritte ohne schriftliche Zustimmung der Firma ist strikt untersagt, gemäß den EU Gesetzen für Copyrights und geistiges Eigentum.

Ce document est la propriété exclusive de la société ALESSIO (I). La reproduction ou l'utilisation de ce document par des tiers sans une autorisation écrite de la société est interdite selon les lois CE sur la propriété intellectuelle et le copyright. Questo documento è proprietà esclusiva del Consorzio ALESSIO (I). Ne è pertanto vietata la riproduzione o l'utilizzo con qualsiasi mezzo senza il consenso del consorzio stesso ai sensi delle leggi CE sulla proprietà intellettuale e sul copyright.



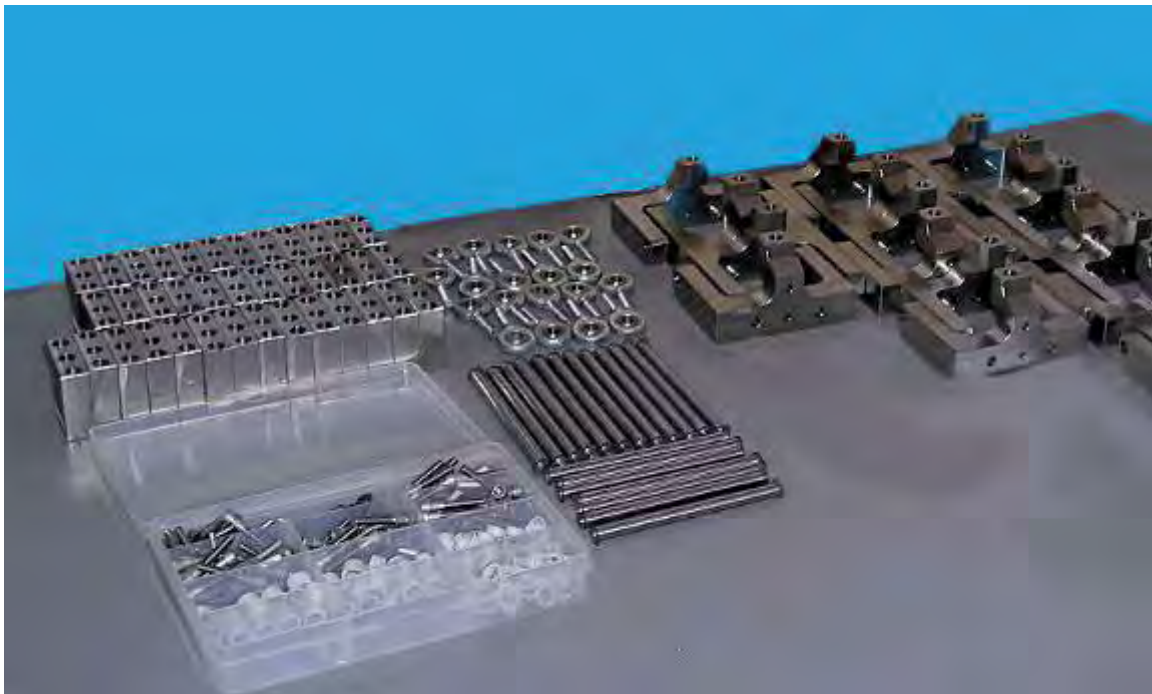

This document is exclusive property of ALESSIO (I). Reproduction or use by a third party without written consent of the company is strictly forbidden, according to EC intellectual property and copyright laws. Dieses Dokument ist exklusives Eigentum von ALESSIO (I). Reproduktion oder Verwendung durch Dritte ohne schriftliche Zustimmung der Firma ist strikt untersagt, gemäß den EU Gesetzen für Copyrights und geistiges Eigentum.

Ce document est la propriété exclusive de la société ALESSIO (I). La reproduction ou l'utilisation de ce document par des tiers sans une autorisation écrite de la société est interdite selon les lois CE sur la propriété intellectuelle et le copyright. Questo documento è proprietà esclusiva del Consorzio ALESSIO (I). Ne è pertanto vietata la riproduzione o l'utilizzo con qualsiasi mezzo senza il consenso del consorzio stesso ai sensi delle leggi CE sulla proprietà intellettuale e sul copyright.

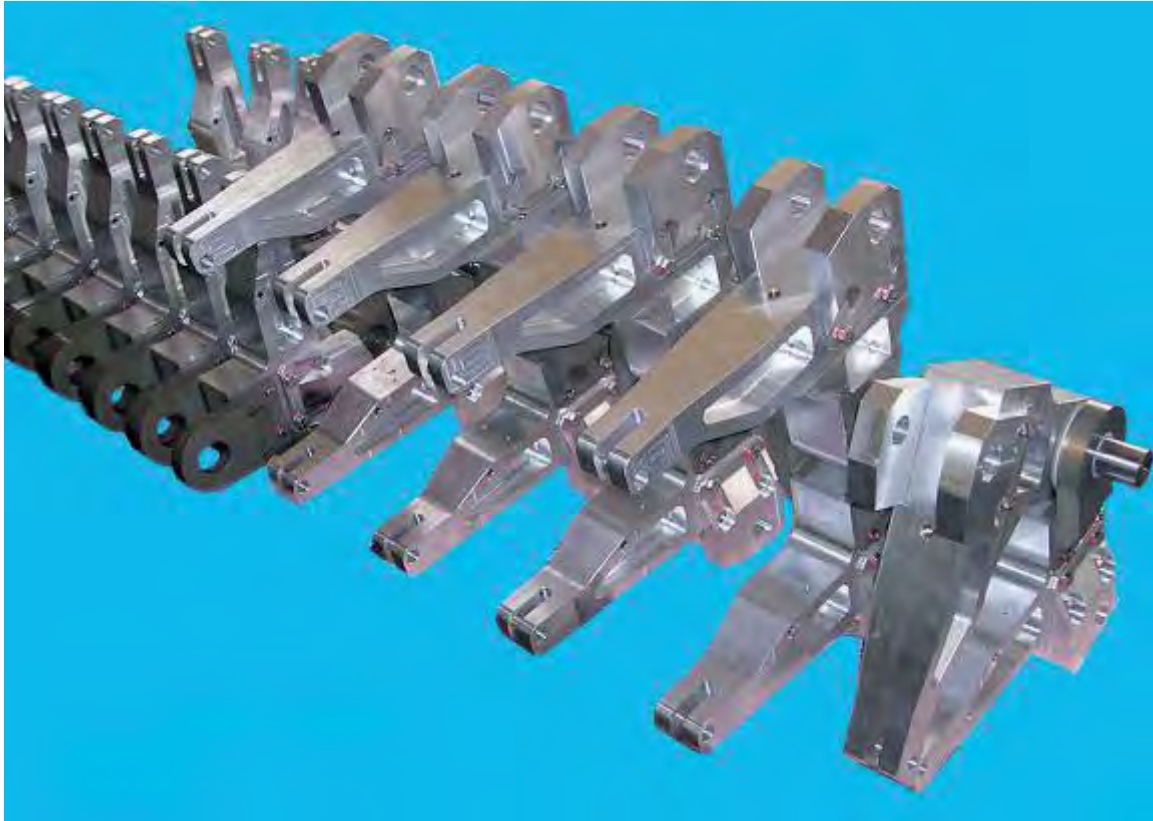

This document is exclusive property of ALESSIO (I). Reproduction or use by a third party without written consent of the company is strictly forbidden, according to EC intellectual property and copyright laws.  
Dieses Dokument ist exklusives Eigentum von ALESSIO (I). Reproduktion oder Verwendung durch Dritte ohne schriftliche Zustimmung der Firma ist strikt untersagt, gemäß den EU Gesetzen für Copyrights und geistiges Eigentum.

Ce document est la propriété exclusive de la société ALESSIO (I). La reproduction ou l'utilisation de ce document par des tiers sans une autorisation écrite de la société est interdite selon les lois CE sur la propriété intellectuelle et le copyright.  
Questo documento è proprietà esclusiva del Consorzio ALESSIO (I). Ne è pertanto vietata la riproduzione o l'utilizzo con qualsiasi mezzo senza il consenso del consorzio stesso ai sensi delle leggi CE sulla proprietà intellettuale e sul copyright.



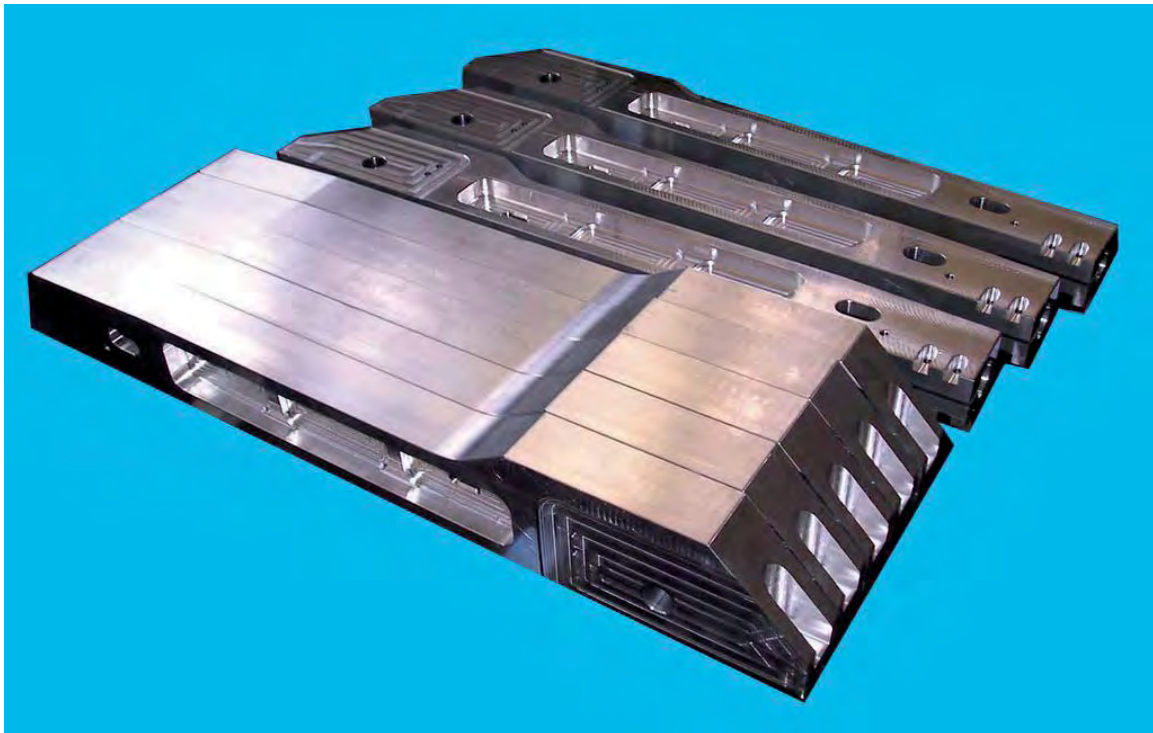
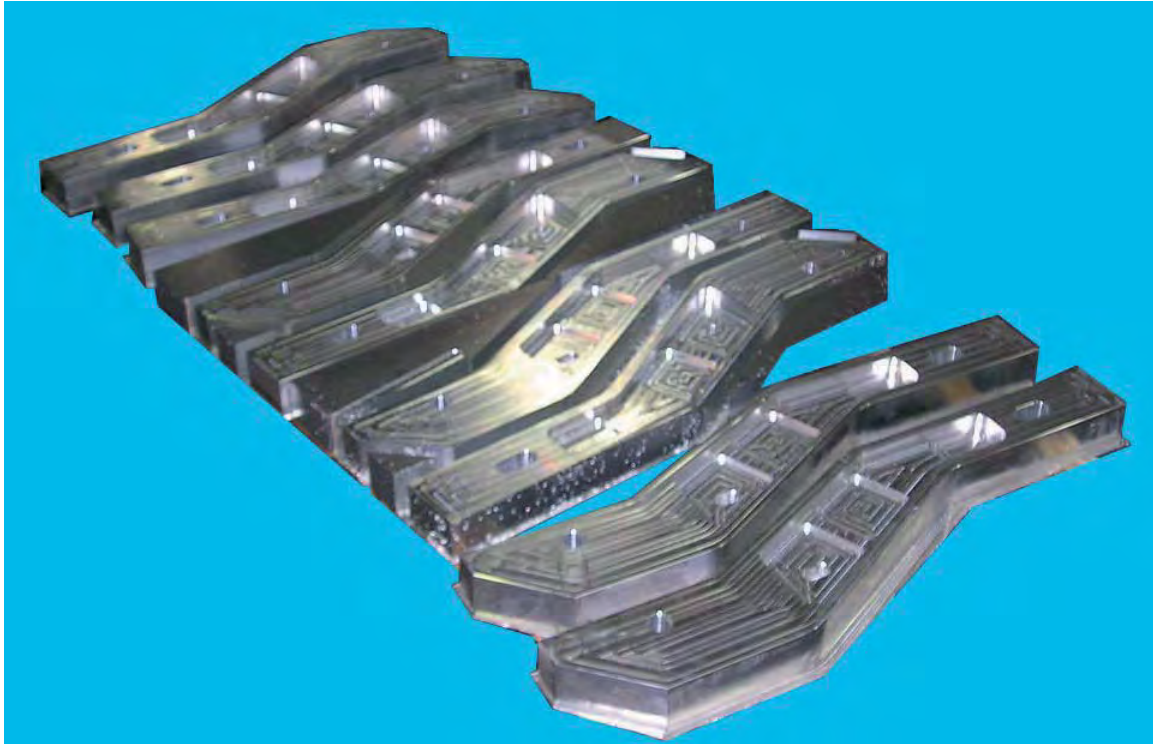

This document is exclusive property of ALESSIO (I). Reproduction or use by a third party without written consent of the company is strictly forbidden, according to EC intellectual property and copyright laws. Dieses Dokument ist exklusives Eigentum von ALESSIO (I). Reproduktion oder Verwendung durch Dritte ohne schriftliche Zustimmung der Firma ist strikt untersagt, gemäß den EU Gesetzen für Copyrights und geistiges Eigentum.

Ce document est la propriété exclusive de la société ALESSIO (I). La reproduction ou l'utilisation de ce document par des tiers sans une autorisation écrite de la société est interdite selon les lois CE sur la propriété intellectuelle et le copyright. Questo documento è proprietà esclusiva del Consorzio ALESSIO (I). Ne è pertanto vietata la riproduzione o l'utilizzo con qualsiasi mezzo senza il consenso del consorzio stesso ai sensi delle leggi CE sulla proprietà intellettuale e sul copyright.



This document is exclusive property of ALESSIO (I). Reproduction or use by a third party without written consent of the company is strictly forbidden, according to EC intellectual property and copyright laws.  
Dieses Dokument ist exklusives Eigentum von ALESSIO (I). Reproduktion oder Verwendung durch Dritte ohne schriftliche Zustimmung der Firma ist strikt untersagt, gemäß den EU Gesetzen für Copyrights und geistiges Eigentum.



Ce document est la propriété exclusive de la société ALESSIO (I). La reproduction ou l'utilisation de ce document par des tiers sans une autorisation écrite de la société est interdite selon les lois CE sur la propriété intellectuelle et le copyright.  
Questo documento è proprietà esclusiva del Consorzio ALESSIO (I). Ne è pertanto vietata la riproduzione o l'utilizzo con qualsiasi mezzo senza il consenso del consorzio stesso ai sensi delle leggi CE sulla proprietà intellettuale e sul copyright.

# ELECTRIC SERVO-GUNS

the FUTURE of welding guns!

You can change  
Force & Stroke  
at each spot

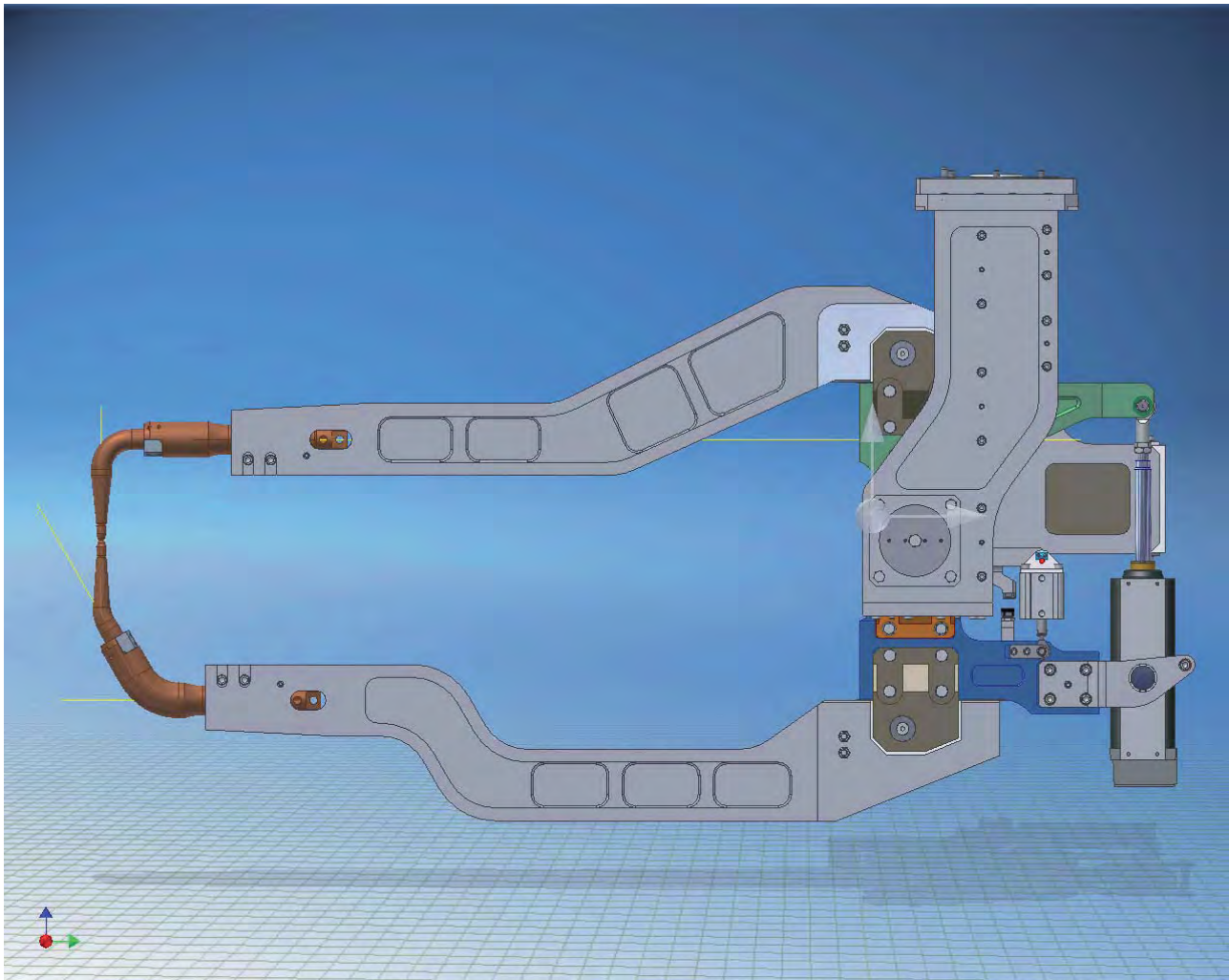

This document is exclusive property of ALESSIO (I). Reproduction or use by a third party without written consent of the company is strictly forbidden, according to EC intellectual property and copyright laws.  
Dieses Dokument ist exklusives Eigentum von ALESSIO (I). Reproduktion oder Verwendung durch Dritte ohne schriftliche Zustimmung der Firma ist strikt untersagt, gemäß den EU Gesetzen für Copyrights und geistiges Eigentum.

Ce document est la propriété exclusive de la société ALESSIO (I). La reproduction ou l'utilisation de ce document par des tiers sans une autorisation écrite de la société est interdite selon les lois CE sur la propriété intellectuelle et le copyright.  
Questo documento è proprietà esclusiva del Consorzio ALESSIO (I). Ne è pertanto vietata la riproduzione o l'utilizzo con qualsiasi mezzo senza il consenso del consorzio stesso ai sensi delle leggi CE sulla proprietà intellettuale e sul copyright.



This document is exclusive property of ALESSIO (I). Reproduction or use by a third party without written consent of the company is strictly forbidden, according to EC intellectual property and copyright laws.  
Dieses Dokument ist exklusives Eigentum von ALESSIO (I). Reproduktion oder Verwendung durch Dritte ohne schriftliche Zustimmung der Firma ist strikt untersagt, gemäß den EU Gesetzen für Copyrights und geistiges Eigentum.

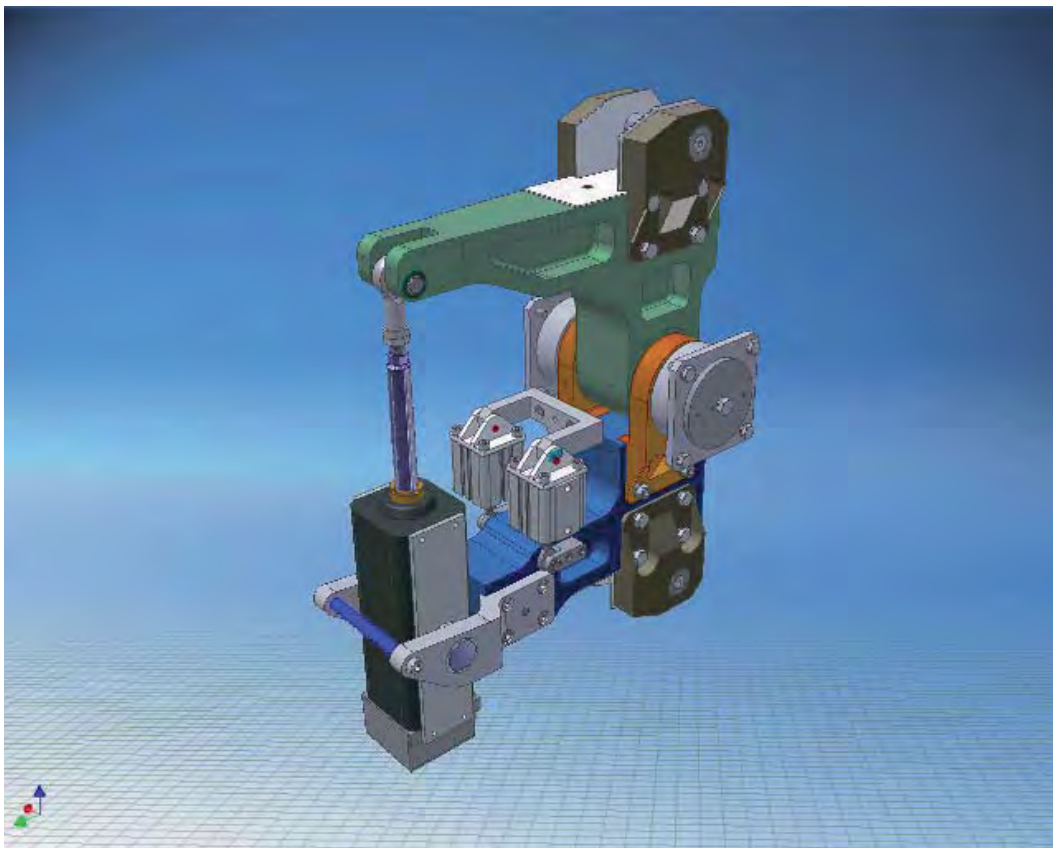
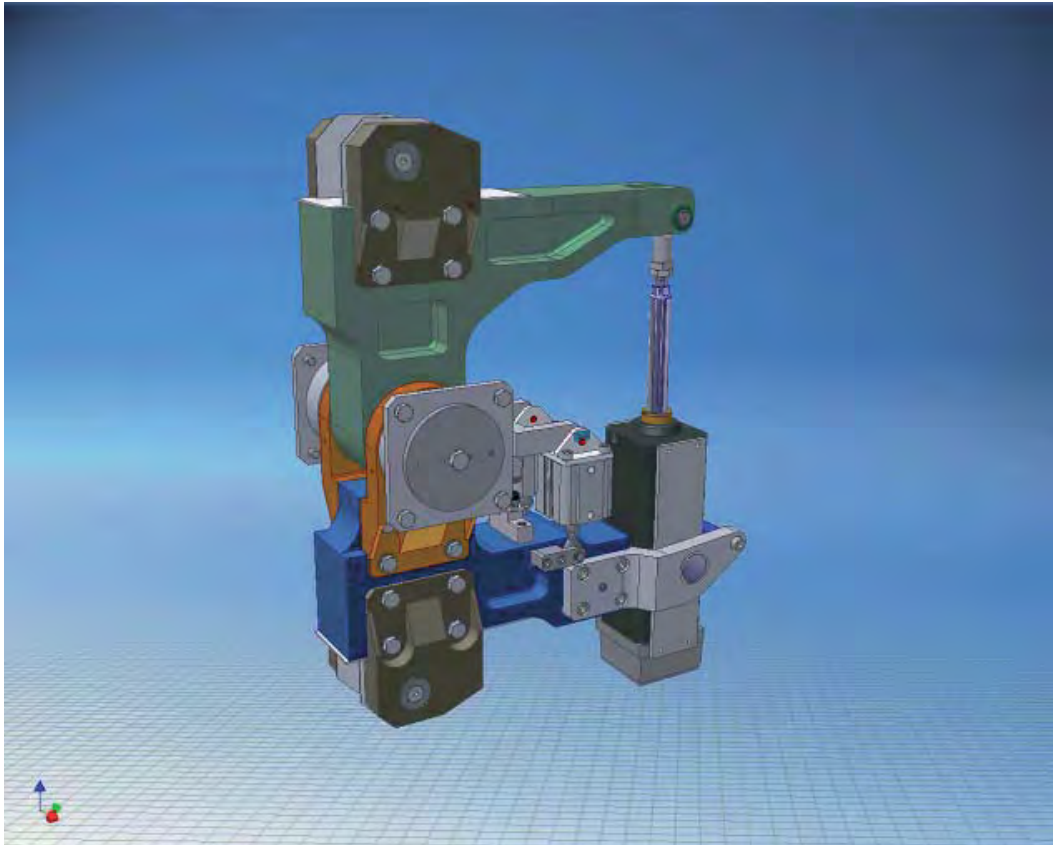

Ce document est la propriété exclusive de la société ALESSIO (I). La reproduction ou l'utilisation de ce document par des tiers sans une autorisation écrite de la société est interdite selon les lois CE sur la propriété intellectuelle et le copyright.  
Questo documento è proprietà esclusiva del Consorzio ALESSIO (I). Ne è pertanto vietata la riproduzione o l'utilizzo con qualsiasi mezzo senza il consenso del consorzio stesso ai sensi delle leggi CE sulla proprietà intellettuale e sul copyright.



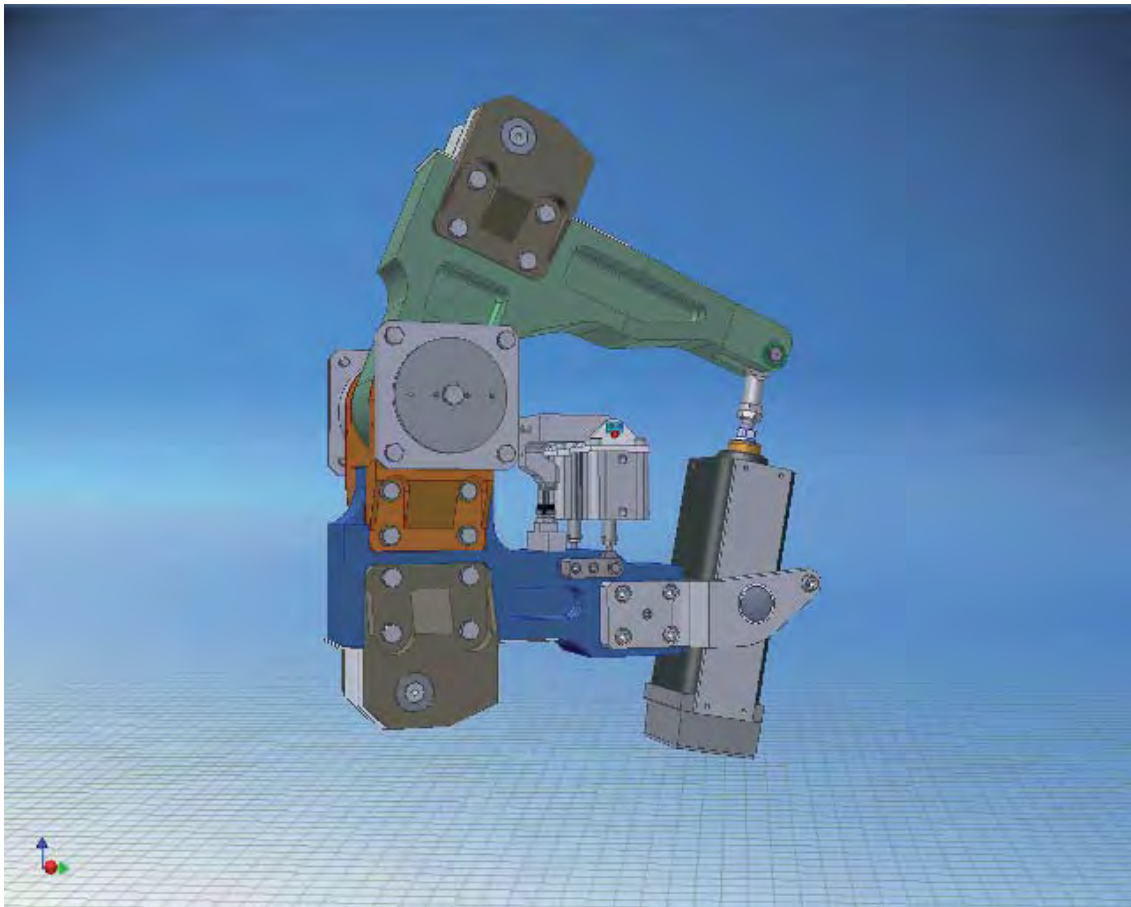
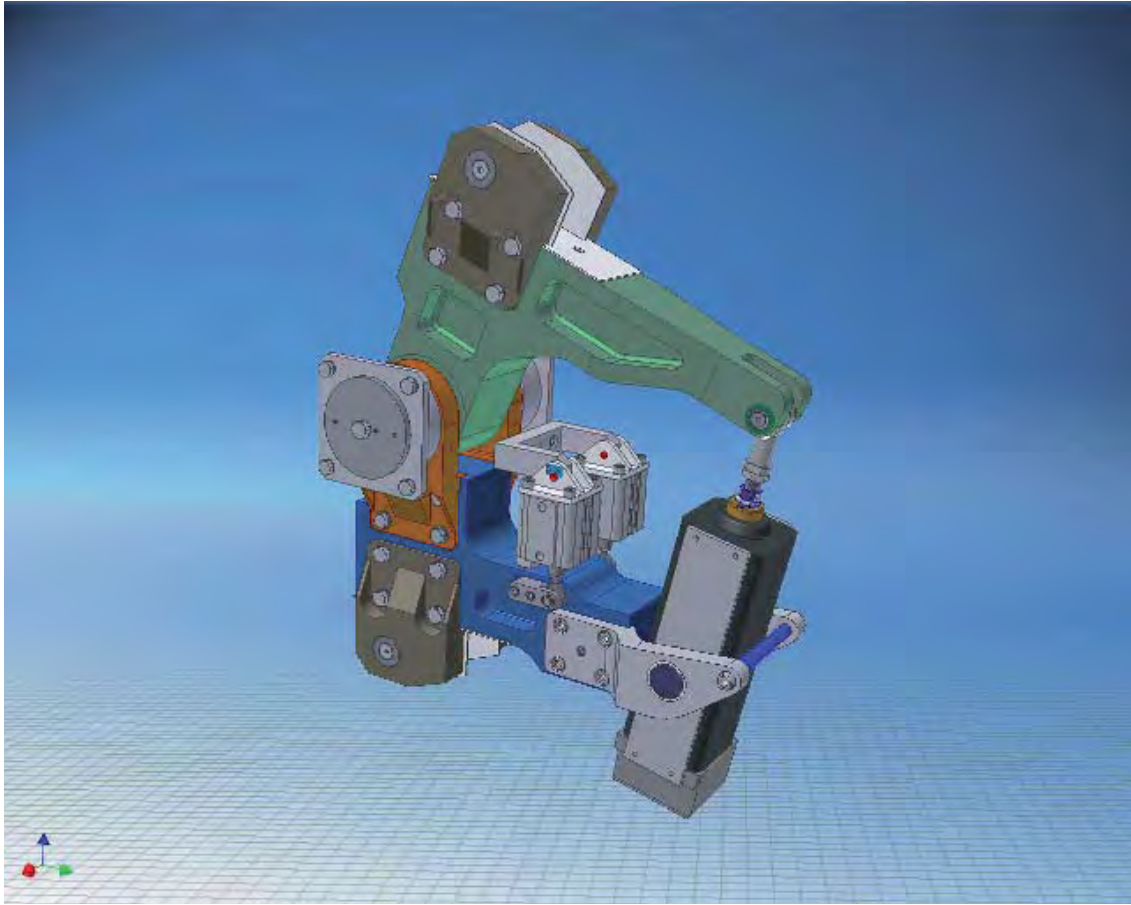

This document is exclusive property of ALESSIO (I). Reproduction or use by a third party without written consent of the company is strictly forbidden, according to EC intellectual property and copyright laws.  
Dieses Dokument ist exclusives Eigentum von ALESSIO (I). Reproduktion oder Verwendung durch Dritte ohne schriftliche Zustimmung der Firma ist strikt untersagt, gemäß den EU-Gesetzen für Copyrights und geistiges Eigentum.

Ce document est la propriété exclusive de la société ALESSIO (I). La reproduction ou l'utilisation de ce document par des tiers sans une autorisation écrite de la société est interdite selon les lois CE sur la propriété intellectuelle et le copyright.  
Questo documento è proprietà esclusiva del Consorzio ALESSIO (I). Ne è pertanto vietata la riproduzione o l'utilizzo con qualsiasi mezzo senza il consenso del consorzio stesso ai sensi delle leggi CE sulla proprietà intellettuale e sul copyright.

This document is exclusive property of ALESSIO (I). Reproduction or use by a third party without written consent of the company is strictly forbidden, according to EC intellectual property and copyright laws.  
Dieses Dokument ist exklusives Eigentum von ALESSIO (I). Reproduktion oder Verwendung durch Dritte ohne schriftliche Zustimmung der Firma ist strikt untersagt, gemäß den EU Gesetzen für Copyrights und geistiges Eigentum.

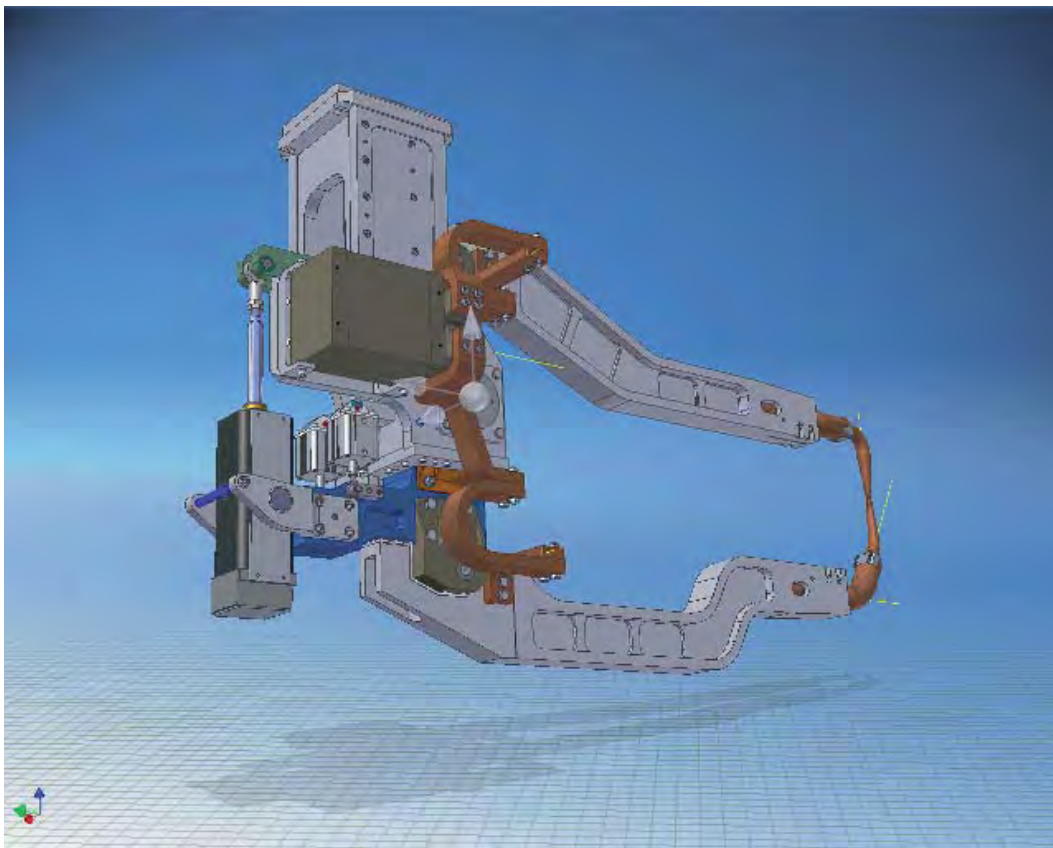
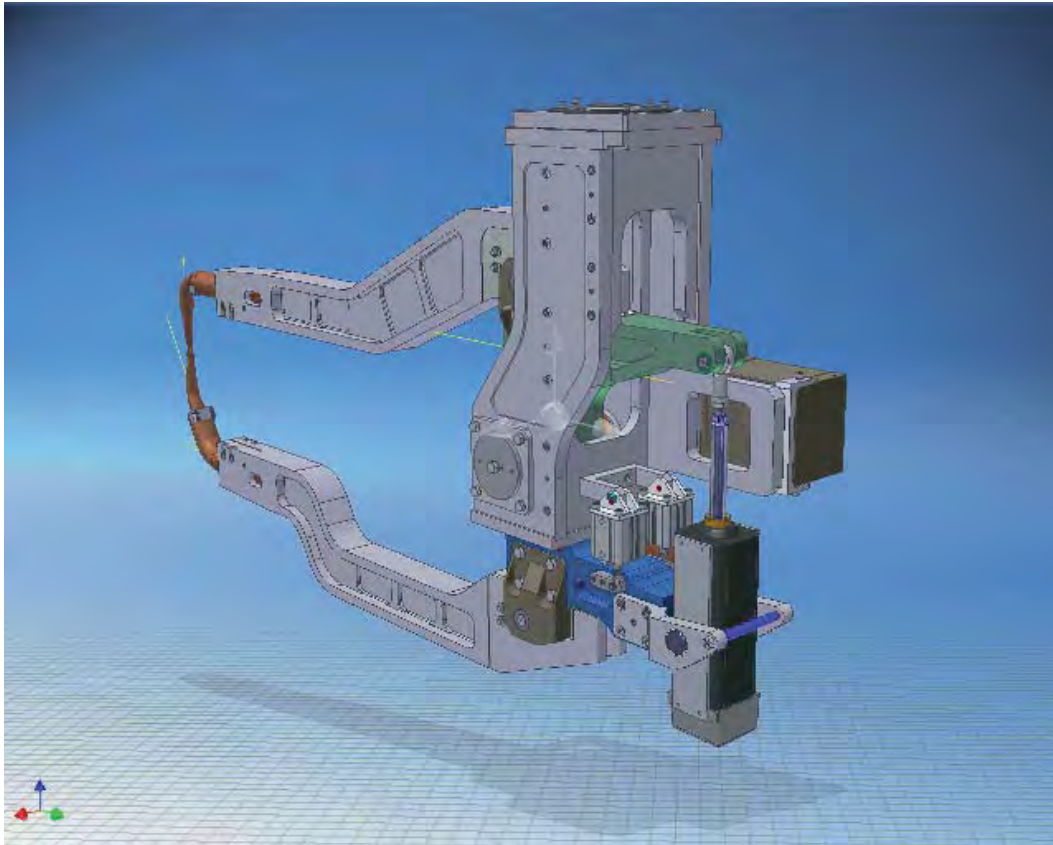

Ce document est la propriété exclusive de la société ALESSIO (I). La reproduction ou l'utilisation de ce document par des tiers sans une autorisation écrite de la société est interdite selon les lois CE sur la propriété intellectuelle et le copyright.  
Questo documento è proprietà esclusiva del Consorzio ALESSIO (I). Ne è pertanto vietata la riproduzione o l'utilizzo con qualsiasi mezzo senza il consenso del consorzio stesso ai sensi delle leggi CE sulla proprietà intellettuale e sul copyright.



This document is exclusive property of ALESSIO (I). Reproduction or use by a third party without written consent of the company is strictly forbidden, according to EC intellectual property and copyright laws. Dieses Dokument ist exklusives Eigentum von ALESSIO (I). Reproduktion oder Verwendung durch Dritte ohne schriftliche Zustimmung der Firma ist strikt untersagt, gemäß den EU Gesetzen für Copyrights und geistiges Eigentum.

Customer Approval History	
Dalle	APPROVED/DATE
12/18/05	Sent For Customer Approval

Feedback Wiring		Power Wiring	
Pin	Wire Color	Wire Color	Function
1	Therm Lead 1	Red	M1
2	Blue	Blue	M3
3	Black	Green	PE
4	Black/White	Black	M2
5	Therm Lead 2		
6	Yellow		
7	Red		
8	Red/White		
9			
10			
11			
12			
Case	Bare(s)		Shield

UNLESS SPECIFIED:	
Pin	Wire Color
1	Red
2	Blue
3	Green
4	Black
5	Black/White
6	Yellow
7	Red
8	Red/White
9	
10	
11	
12	
Case	Bare(s)

<b>EXLARA</b>	
THE INFORMATION CONTAINED IN THIS DRAWING IS THE SOLE PROPERTY OF ALESSIO (I). ANY REPRODUCTION IN PART OR AS A WHOLE WITHOUT THE WRITTEN PERMISSION OF ALESSIO (I) IS PROHIBITED.	
Description: <b>GSX40-0602-ITA-EL1-258</b>	
SIZE	Part Number: <b>25237</b>
REV	Model: <b>GSX40</b>
<b>A</b>	DO NOT SCALE FROM DRAWING
	SHEET 1 OF 1

This document is the exclusive property of the company ALESSIO (I). The reproduction or the use of this document by third parties without the written consent of ALESSIO (I) is strictly prohibited. Ce document est la propriété exclusive de la société ALESSIO (I). La reproduction ou l'utilisation de ce document par des tiers sans une autorisation écrite de la société est interdite selon les lois CE sur la propriété intellectuelle et le copyright. Questo documento è proprietà esclusiva del Consorzio ALESSIO (I). Ne è pertanto vietata la riproduzione o l'utilizzo con qualsiasi mezzo senza il consenso del consorzio stesso ai sensi delle leggi CE sulla proprietà intellettuale e sul copyright.



This document is exclusive property of ALESSIO (I). Reproduction or use by a third party without written consent of the company is strictly forbidden, according to EC intellectual property and copyright laws. Dieses Dokument ist exklusives Eigentum von ALESSIO (I). Reproduktion oder Verwendung durch Dritte ohne schriftliche Zustimmung der Firma ist strikt untersagt, gemäß den EU Gesetzen für Copyrights und geistiges Eigentum.

Customer Approval History	
Date	APPROVED-DATE
2/18/05	Sent For Customer Approval

Feedback Wiring		Power Wiring	
Pin	Wire Color	Pin	Wire Color
1	Therm Lead 1	1	Red
2	Blue	2	Blue
3	Black	3	Green
4	Black/White	4	Black
5	Therm Lead 2	5	Black
6	Yellow	E	
7	Red		
8	Red/White		
9			
10			
11			
12			
Case	Bare(s)		
	Shield		

<b>EXLAR</b>	
THE INFORMATION CONTAINED IN THIS DRAWING IS THE SOLE PROPERTY OF EXLAR. ANY REPRODUCTION IN PART OR AS A WHOLE WITHOUT THE WRITTEN PERMISSION OF EXLAR IS PROHIBITED.	
Description <b>GSX40-0605-IMA-EL1-258</b>	
UNLESS SPECIFIED: Pin: "in or mm" Plus "in or mm" 1 pin=±0.1    3 pins=±0.005 2 pins=±0.01    4 pins=±0.002 Inside Edge Break: 0.005"±0.001 Outside Edge Break: 0.005" to 0.015" Angles: ±1/2° Finish: 63 µinches R.M.S.	Material: N/A Finish/Treat: N/A
Dimensions Shown In: <b>INCHES</b> Drawing Date: TRW 2/18/05 Eng. Appr: N/A Dwg. Appr: N/A	Part Number: <b>25238</b> Model: <b>GSX40</b>
SIZE: <b>A</b>	REV: <b>2/18/05</b>
DO NOT SCALE FROM DRAWING SHEET 1 OF 1	

Ce document est la propriété exclusive de la société ALESSIO (I). La reproduction ou l'utilisation de ce document par des tiers sans une autorisation écrite de la société est interdite selon les lois CE sur la propriété intellectuelle et le copyright. Questo documento è proprietà esclusiva del Consorzio ALESSIO (I). Ne è pertanto vietata la riproduzione o l'utilizzo con qualsiasi mezzo senza il consenso del consorzio stesso ai sensi delle leggi CE sulla proprietà intellettuale e sul copyright.

## 5.2 GSX Mechanical / Electrical Specifications (Cont'd)

		<b>GSX40</b>									
Nominal Backlash	in (mm)	0.004 (.10)									
Maximum Backlash (pre-loaded)	in (mm)	0									
Lead Accuracy	in/ft (mm/300 mm)	0.001 (.025)									
Maximum Radial Load	lb (N)	40 (179)									
Environmental Rating:	Std / Opt.	IP65/67									
<b>MOTOR STATOR</b>		<b>118</b>	<b>138</b>	<b>158</b>	<b>168</b>	<b>238</b>	<b>258</b>	<b>268</b>	<b>338</b>	<b>358</b>	<b>368</b>
<b>RMS Sinusoidal Commutation</b>											
Continuous Motor Torque	Lbf-in	47.6	47.6	44.7	45.5	78.9	78.8	79.7	107.1	105.5	107.1
	(N-m)	(5.38)	(5.37)	(5.05)	(5.14)	(8.91)	(8.91)	(9.00)	(12.10)	(11.92)	(12.10)
Torque Constant (Kt)	Lbf-in/A	4.1	8.2	14.6	16.8	8.2	14.6	16.8	8.4	14.6	16.8
	+/- 10% @ 25 °C (N-m/A)	(0.46)	(0.93)	1.65	(1.90)	(0.93)	(1.65)	(1.90)	(0.95)	(1.65)	(1.90)
Cont. Current Rating: Greased (IG),	A	12.9	6.5	3.4	3.0	10.7	6.0	5.3	14.2	8.1	7.1
	Oiled (IL), A	25.9	12.9	6.9	6.0	21.4	12.1	10.6	28.5	16.2	14.2
Peak Current Rating	A	25.9	12.9	6.9	6.0	21.4	12.1	10.6	28.5	16.2	14.2
<b>Trapezoidal Commutation</b>											
Continuous Motor Torque	Lbf-in	45.5	45.4	42.7	43.5	75.3	75.3	76.1	102.3	100.7	102.3
	(N-m)	(5.14)	(5.13)	(4.83)	(4.91)	(9.51)	(8.50)	(8.60)	(11.56)	(11.38)	(11.56)
Torque Constant (Kt)	Lbf-in/A	3.2	6.4	11.4	13.1	6.4	11.4	13.1	6.6	11.4	13.1
	+/- 10% @ 25 °C (N-m/A)	(0.36)	(0.72)	(1.28)	(1.48)	(0.72)	(1.28)	(1.48)	(0.74)	(1.28)	(1.48)
Cont. Current Rating: Greased (IG),	A	15.9	7.9	4.2	3.7	13.1	7.4	6.5	17.4	9.9	8.7
	Oiled (IL), A	31.7	15.8	8.4	7.4	26.3	14.8	13.0	34.9	19.8	17.4
Peak Current Rating	A	31.7	15.8	8.4	7.4	26.3	14.8	13.0	34.9	19.8	17.4
<b>Motor Stator Data</b>											
Voltage Constant (Ke)	Vrms / Krpm	28.1	56.1	99.5	114.8	56.1	99.5	114.8	57.4	99.5	114.8
+/- 10% @ 25 °C	Vpk / Krpm	39.7	79.4	140.7	162.4	79.4	140.7	162.4	81.2	140.7	162.4
Pole Configuration		8	8	8	8 8 8 8 8					8	8
Resistance (L-L) +/- 5% @ 25 °C	Ohms	0.4	1.7	6.0	7.8	0.7	2.26	3.0	0.5	1.52	1.9
Inductance (L-L) +/- 15%	mH	3.0	11.9	37.5	49.9	5.8	18.2	24.2	4.0	12.0	16.0
Brake Inertia	lbf-in-sec <sup>2</sup>	0.00									
	Kg-cm <sup>2</sup> ( )	0.06									
Brake Current @ 24 Vdc	A	0.67									
Brake Holding Torque	lb	97									
	(N)	(11)									
Brake Engage/Disengage Time	ms	20/29									
Mechanical Time Constant (tm), ms	min	5.3	5.3	6.0	5.8	2.3	2.3	2.2	1.5	1.5	1.5
	max	7.7	7.7	8.7	8.4	3.3	3.3	3.2	2.1	2.2	2.1
Electrical Time Constant (te)	ms	7.0	7.0	6.2	6.4	8.0	8.0	8.2	8.2	7.9	8.2
Damping Constant	lbf-in/krpm	3.25	3.25	3.25	3.25	3.25	3.25	3.25	3.25	3.25	3.25
	(N-m/krpm)	(0.37)	(0.37)	(0.37)	(0.37)	(0.37)	(0.37)	(0.37)	(0.37)	(0.37)	(0.37)
Friction Torque	lbf-in	4.50	4.50	4.50	4.50	4.50	4.50	4.50	4.50	4.50	4.50
	(Nm)	(0.51)	(0.51)	(0.51)	(0.51)	(0.51)	(0.51)	(0.51)	(0.51)	(0.51)	(0.51)
Bus Voltage	Vrms	115	230	400	460	230	400	460	230	400	460
Speed @ Bus Voltage	RPM	3000	3000	3000	3000	3000	3000	3000	3000	3000	3000
Thermal Switch, case temperature	deg C	100									
Motor Wire Insulation		Class H									
Motor Stator Rating		Class H									

All ratings at 25 degrees Celsius. For amplifiers using peak sinusoidal ratings, multiply K<sub>t</sub> by .707 and current by 1.414. Refer to Performance Specifications for availability of 3 stack stator by stroke/lead combination. Test data derived using NEMA recommended aluminum heatsink 12" x 12" x 1/2".

**OPENING between electrodes with different ARM LENGTHS vs. strokes of Electric Cylinder (CS) (All dimensions in mm)**

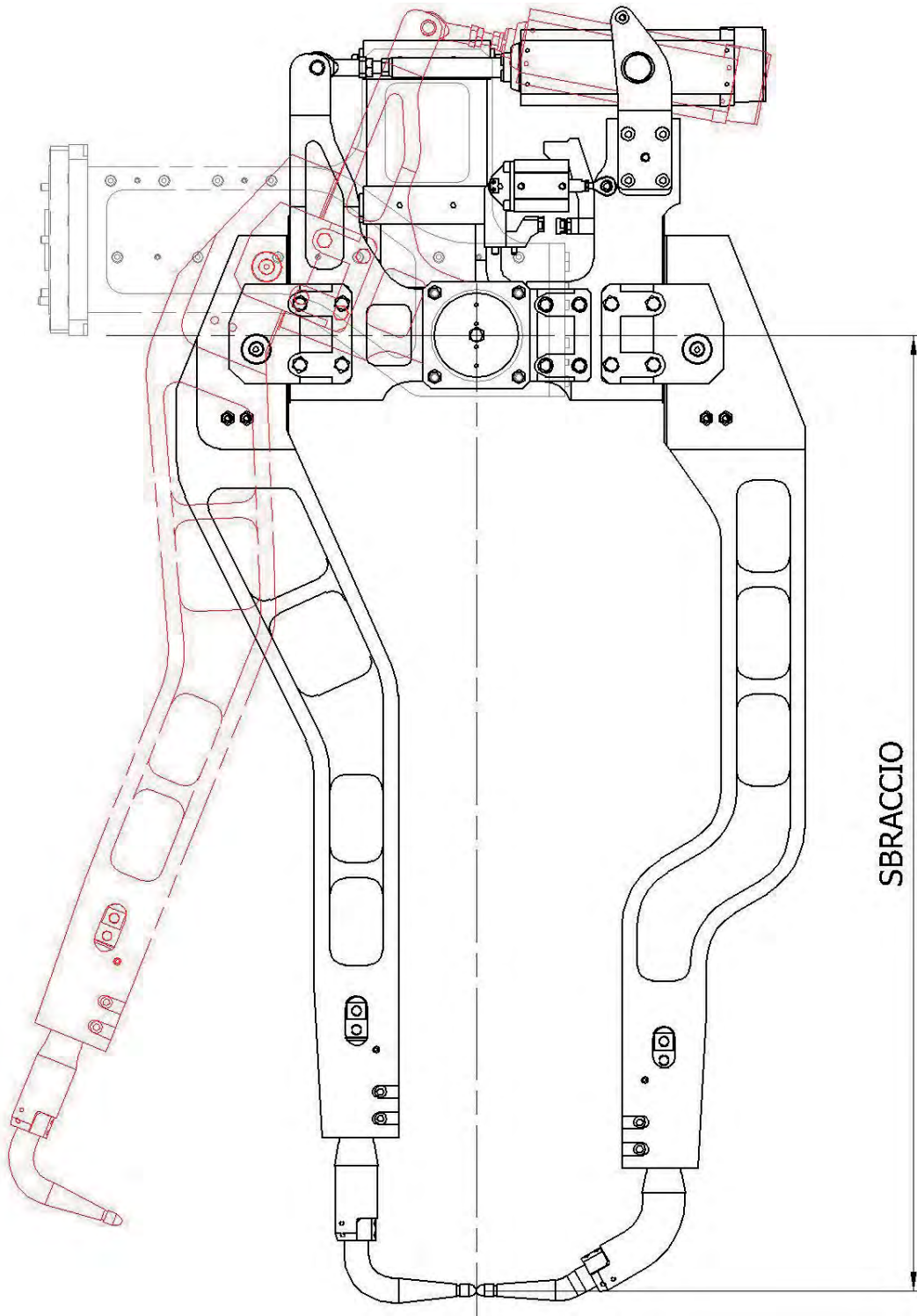

This document is exclusive property of ALESSIO (I). Reproduction or use by a third party without written consent of the company is strictly forbidden, according to EC intellectual property and copyright laws. Dieses Dokument ist exklusives Eigentum von ALESSIO (I). Reproduktion oder Verwendung durch Dritte ohne schriftliche Zustimmung der Firma ist strikt untersagt, gemäß den EU Gesetzen für Copyrights und geistiges Eigentum.

Ce document est la propriété exclusive de la société ALESSIO (I). La reproduction ou l'utilisation de ce document par des tiers sans une autorisation écrite de la société est interdite selon les lois CE sur la propriété intellectuelle et le copyright. Questo documento è proprietà esclusiva del Consorzio ALESSIO (I). Ne è pertanto vietata la riproduzione o l'utilizzo con qualsiasi mezzo senza il consenso del consorzio stesso ai sensi delle leggi CE sulla proprietà intellettuale e sul copyright.



## OPENING between electrodes with different **ARM LENGTHS** vs. strokes of Electric Cylinder (CS) (All dimensions in mm)

<b>CS</b>	<b>Arm lenght 700</b>	<b>Arm lenght 900</b>	<b>Arm lenght 1100</b>	<b>Arm lenght 1300</b>	<b>Arm lenght 1500</b>
0	0	0	0	0	0
1	2	3	3	4	4
2	4	5	6	7	9
3	6	8	9	11	13
4	8	10	13	15	17
5	10	13	16	19	21
6	12	15	19	22	26
7	14	18	22	26	30
8	16	20	25	30	34
9	18	23	28	33	38
10	20	26	31	37	43
11	22	28	34	41	47
12	24	31	37	44	51
13	26	33	41	48	55
14	28	36	44	52	60
15	30	38	47	55	64
16	32	41	50	59	68
17	34	43	53	63	72
18	36	46	56	66	76
19	38	48	59	70	81
20	40	51	62	74	85
21	42	53	65	77	89
22	44	56	68	81	93
23	45	58	71	84	97
24	47	61	75	88	102
25	49	63	78	92	106
26	51	66	81	95	110
27	53	68	84	99	114
28	55	71	87	103	118
29	57	73	90	106	122
30	59	76	93	110	127
31	61	78	96	113	131
32	63	81	99	117	135
33	65	83	102	121	139
34	67	86	105	124	143
35	69	88	108	128	147
36	71	91	111	131	152
37	73	93	114	135	156
38	75	96	117	139	160
39	77	98	120	142	164
40	78	101	123	146	168
41	80	103	126	149	172
42	82	106	129	153	176
43	84	108	132	156	180
44	86	111	135	160	185
45	88	113	138	163	189
46	90	116	141	167	193

This document is exclusive property of ALESSIO (I). Reproduction or use by a third party without written consent of the company is strictly forbidden, according to EC intellectual property and copyright laws. Dieses Dokument ist exklusives Eigentum von ALESSIO (I). Reproduktion oder Verwendung durch Dritte ohne schriftliche Zustimmung der Firma ist strikt untersagt, gemäß den EU Gesetzen für Copyrights und geistiges Eigentum.

Ce document est la propriété exclusive de la société ALESSIO (I). La reproduction ou l'utilisation de ce document par des tiers sans une autorisation écrite de la société est interdite selon les lois CE sur la propriété intellectuelle et le copyright. Questo documento è proprietà esclusiva del Consorzio ALESSIO (I). Ne è pertanto vietata la riproduzione o l'utilizzo con qualsiasi mezzo senza il consenso del consorzio stesso ai sensi delle leggi CE sulla proprietà intellettuale e sul copyright.

## OPENING between electrodes with different **ARM LENGTHS** vs. strokes of Electric Cylinder (CS) (All dimensions in mm)

<b>CS</b>	<b>Arm lenght 700</b>	<b>Arm lenght 900</b>	<b>Arm lenght 1100</b>	<b>Arm lenght 1300</b>	<b>Arm lenght 1500</b>
47	92	118	144	171	197
48	94	121	147	174	201
49	96	123	150	178	205
50	98	125	153	181	209
51	99	128	156	185	213
52	101	130	159	188	217
53	103	133	162	192	221
54	105	135	165	195	225
55	107	138	168	199	229
56	109	140	171	202	233
57	111	142	174	206	237
58	113	145	177	209	242
59	115	147	180	213	246
60	116	150	183	216	250
61	118	152	186	220	254
62	120	155	189	223	258
63	122	157	192	227	262
64	124	159	195	230	266
65	126	162	198	234	270
66	128	164	201	237	274
67	130	167	204	241	278
68	131	169	207	244	282
69	133	171	210	248	286
70	135	174	212	251	290
71	137	176	215	255	294
72	139	179	218	258	298
73	141	181	221	261	302
74	143	183	224	265	306
75	144	186	227	268	310
76	146	188	230	272	314
77	148	190	233	275	317
78	150	193	236	279	321
79	152	195	239	282	325
80	154	198	242	285	329
81	156	200	244	289	333
82	157	202	247	292	337
83	159	205	250	296	341
84	161	207	253	299	345
85	163	209	256	302	349
86	165	212	259	306	353
87	167	214	262	309	357
88	168	216	265	313	361
89	170	219	267	316	365
90	172	221	270	319	368
91	174	223	273	323	372
92	176	226	276	326	376
93	177	228	279	329	380

This document is exclusive property of ALESSIO (I). Reproduction or use by a third party without written consent of the company is strictly forbidden, according to EC intellectual property and copyright laws. Dieses Dokument ist exklusives Eigentum von ALESSIO (I). Reproduktion oder Verwendung durch Dritte ohne schriftliche Zustimmung der Firma ist strikt untersagt, gemäß den EU Gesetzen für Copyrights und geistiges Eigentum.

Ce document est la propriété exclusive de la société ALESSIO (I). La reproduction ou l'utilisation de ce document par des tiers sans une autorisation écrite de la société est interdite selon les lois CE sur la propriété intellectuelle et le copyright. Questo documento è proprietà esclusiva del Consorzio ALESSIO (I). Ne è pertanto vietata la riproduzione o l'utilizzo con qualsiasi mezzo senza il consenso del consorzio stesso ai sensi delle leggi CE sulla proprietà intellettuale e sul copyright.

## OPENING between electrodes with different ARM LENGTHS vs. strokes of Electric Cylinder (CS) (All dimensions in mm)

CS	Arm lenght 700	Arm lenght 900	Arm lenght 1100	Arm lenght 1300	Arm lenght 1500
94	179	230	282	333	384
95	181	233	284	336	388
96	183	235	287	340	392
97	185	237	290	343	396
98	186	240	293	346	399
99	188	242	296	350	403
100	190	244	299	353	407
101	192	247	301	356	411
102	194	249	304	360	415
103	195	251	307	363	419
104	197	253	310	366	422
105	199	256	313	369	426
106	201	258	315	373	430
107	202	260	318	376	434
108	204	263	321	379	438
109	206	265	324	383	442
110	208	267	327	386	445
111	210	269	329	389	449
112	211	272	332	392	453
113	213	274	335	396	457
114	215	276	338	399	460
115	217	279	340	402	464
116	218	281	343	406	468
117	220	283	346	409	472
118	222	285	349	412	475
119	224	288	351	415	479
120	225	290	354	419	483
121	227	292	357	422	487
122	229	294	360	425	490
123	231	296	362	428	494
124	232	299	365	431	498
125	234	301	368	435	502
126	236	303	371	438	505
127	238	305	373	441	509
128	239	308	376	444	513
129	241	310	379	448	516
130	243	312	381	451	520
131	244	314	384	454	524
132	246	316	387	457	527
133	248	319	389	460	531
134	250	321	392	463	535
135	251	323	395	467	538
136	253	325	398	470	542
137	255	327	400	473	546
138	256	330	403	476	549
139	258	332	406	479	553
140	260	334	408	482	557

This document is exclusive property of ALESSIO (I). Reproduction or use by a third party without written consent of the company is strictly forbidden, according to EC intellectual property and copyright laws. Dieses Dokument ist exklusives Eigentum von ALESSIO (I). Reproduktion oder Verwendung durch Dritte ohne schriftliche Zustimmung der Firma ist strikt untersagt, gemäß den EU Gesetzen für Copyrights und geistiges Eigentum.

Ce document est la propriété exclusive de la société ALESSIO (I). La reproduction ou l'utilisation de ce document par des tiers sans une autorisation écrite de la société est interdite selon les lois CE sur la propriété intellectuelle et le copyright. Questo documento è proprietà esclusiva del Consorzio ALESSIO (I). Ne è pertanto vietata la riproduzione o l'utilizzo con qualsiasi mezzo senza il consenso del consorzio stesso al sensi delle leggi CE sulla proprietà intellettuale e sul copyright.



This document is exclusive property of ALESSIO (I). Reproduction or use by a third party without written consent of the company is strictly forbidden, according to EC intellectual property and copyright laws.  
Dieses Dokument ist exklusives Eigentum von ALESSIO (I). Reproduktion oder Verwendung durch Dritte ohne schriftliche Zustimmung der Firma ist strikt untersagt, gemäss den EU Gesetzen für Copyrights und geistiges Eigentum.

## ELECTRIC GUN Distance between electrodes with different arm lengths

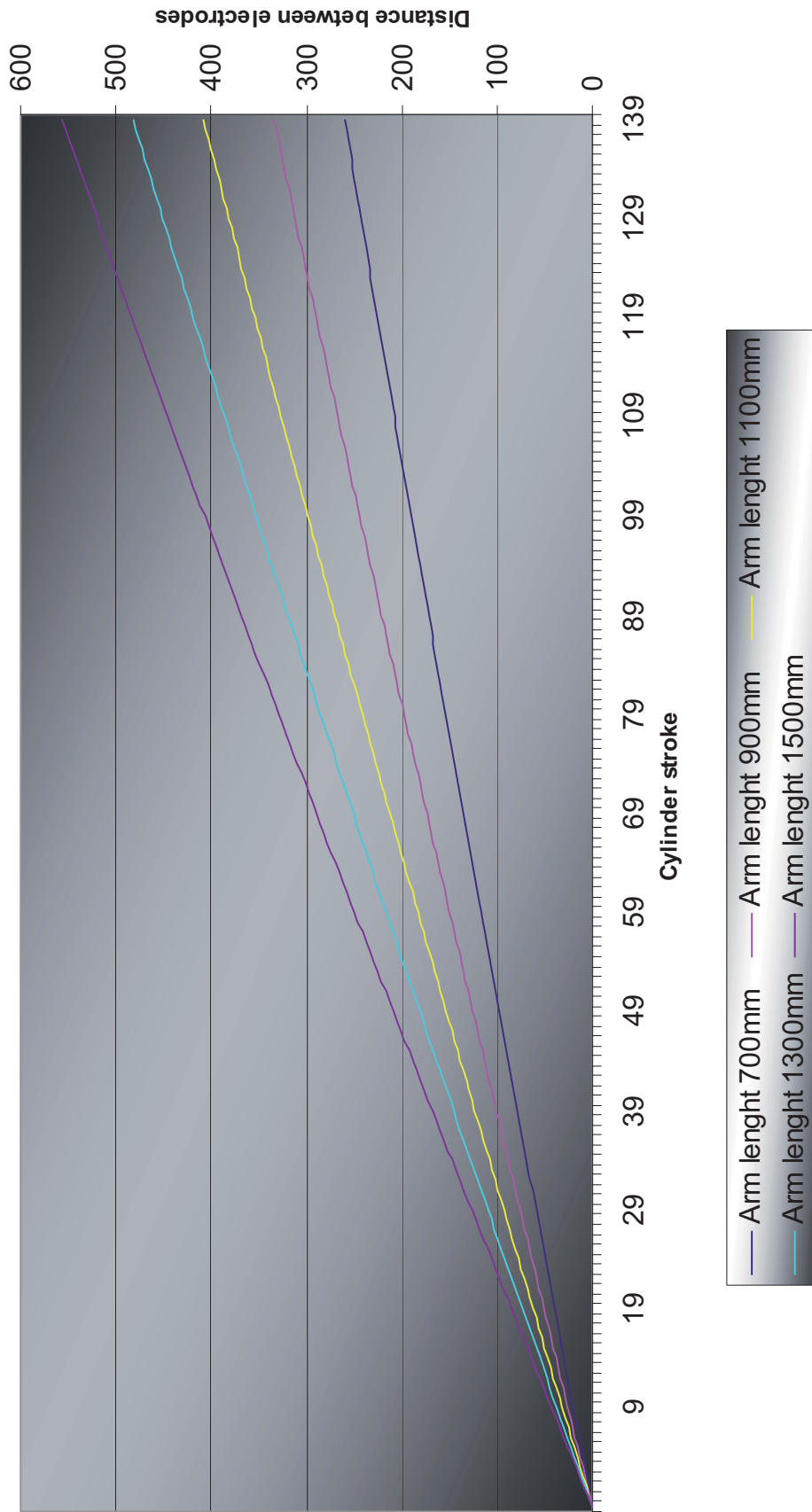

Ce document est la propriété exclusive de la société ALESSIO (I). La reproduction ou l'utilisation de ce document par des tiers sans une autorisation écrite de la société est interdite selon les lois CE sur la propriété intellectuelle et le copyright.  
Questo documento è proprietà esclusiva del Consorzio ALESSIO (I). Ne è pertanto vietata la riproduzione o l'utilizzo con qualsiasi mezzo senza il consenso del consorzio stesso ai sensi delle leggi CE sulla proprietà intellettuale e sul copyright.

# Technical details of Robot MOUNTINGS

This document is exclusive property of ALESSIO (I). Reproduction or use by a third party without written consent of the company is strictly forbidden, according to EC intellectual property and copyright laws.  
Dieses Dokument ist exklusives Eigentum von ALESSIO (I). Reproduktion oder Verwendung durch Dritte ohne schriftliche Zustimmung der Firma ist strikt untersagt, gemäß den EU Gesetzen für Copyrights und geistiges Eigentum.

Ce document est la propriété exclusive de la société ALESSIO (I). La reproduction ou l'utilisation de ce document par des tiers sans une autorisation écrite de la société est interdite selon les lois CE sur la propriété intellectuelle et le copyright.  
Questo documento è proprietà esclusiva del Consorzio ALESSIO (I). Ne è pertanto vietata la riproduzione o l'utilizzo con qualsiasi mezzo senza il consenso del consorzio stesso ai sensi delle leggi CE sulla proprietà intellettuale e sul copyright.

## MOUNTINGS

Two basic standard types of mountings are foreseen,  
for lateral and vertical fixation to the robot

Any other types of mountings  
can be specifically designed  
to fit customer's requirements

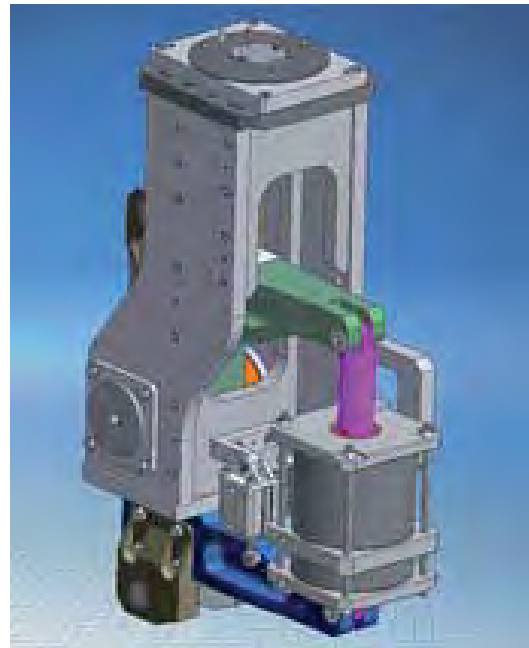
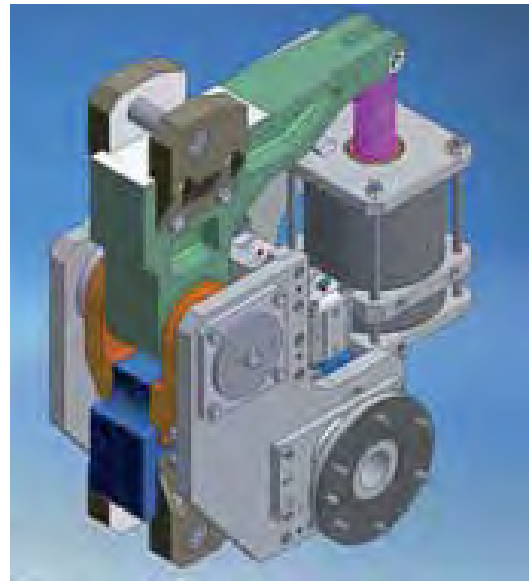

This document is exclusive property of ALESSIO (I). Reproduction or use by a third party without written consent of the company is strictly forbidden, according to EC intellectual property and copyright laws.  
Dieses Dokument ist exklusives Eigentum von ALESSIO (I). Reproduktion oder Verwendung durch Dritte ohne schriftliche Zustimmung der Firma ist strikt untersagt, gemäß den EU-Gesetzen für Copyrights und geistiges Eigentum.

Ce document est la propriété exclusive de la société ALESSIO (I). La reproduction ou l'utilisation de ce document par des tiers sans une autorisation écrite de la société est interdite selon les lois CE sur la propriété intellectuelle et le copyright.  
Questo documento è proprietà esclusiva del Consorzio ALESSIO (I). Ne è pertanto vietata la riproduzione o l'utilizzo con qualsiasi mezzo senza il consenso del consorzio stesso ai sensi delle leggi CE sulla proprietà intellettuale e sul copyright.



This document is exclusive property of ALESSIO (I). Reproduction or use by a third party without written consent of the company is strictly forbidden, according to EC intellectual property and copyright laws.  
Dieses Dokument ist exklusives Eigentum von ALESSIO (I). Reproduktion oder Verwendung durch Dritte ohne schriftliche Zustimmung der Firma ist strikt untersagt, gemäß den EU Gesetzen für Copyrights und geistiges Eigentum.

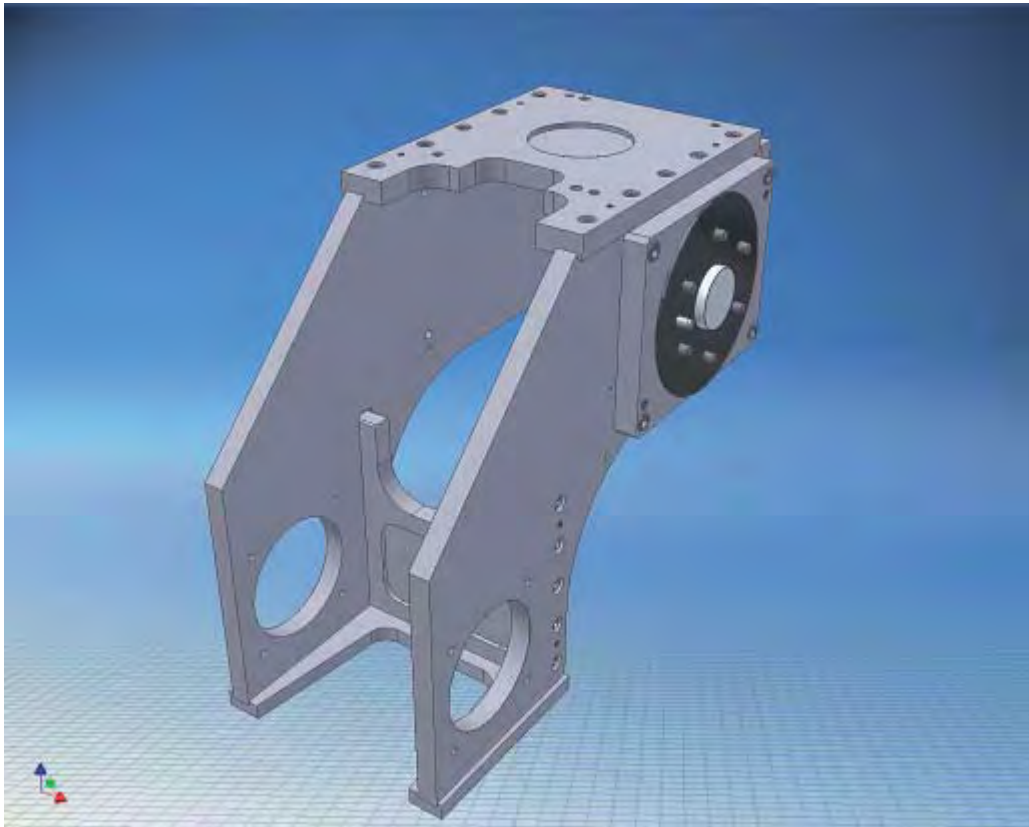

Ce document est la propriété exclusive de la société ALESSIO (I). La reproduction ou l'utilisation de ce document par des tiers sans une autorisation écrite de la société est interdite selon les lois CE sur la propriété intellectuelle et le copyright.  
Questo documento è proprietà esclusiva del Consorzio ALESSIO (I). Ne è pertanto vietata la riproduzione o l'utilizzo con qualsiasi mezzo senza il consenso del consorzio stesso ai sensi delle leggi CE sulla proprietà intellettuale e sul copyright.

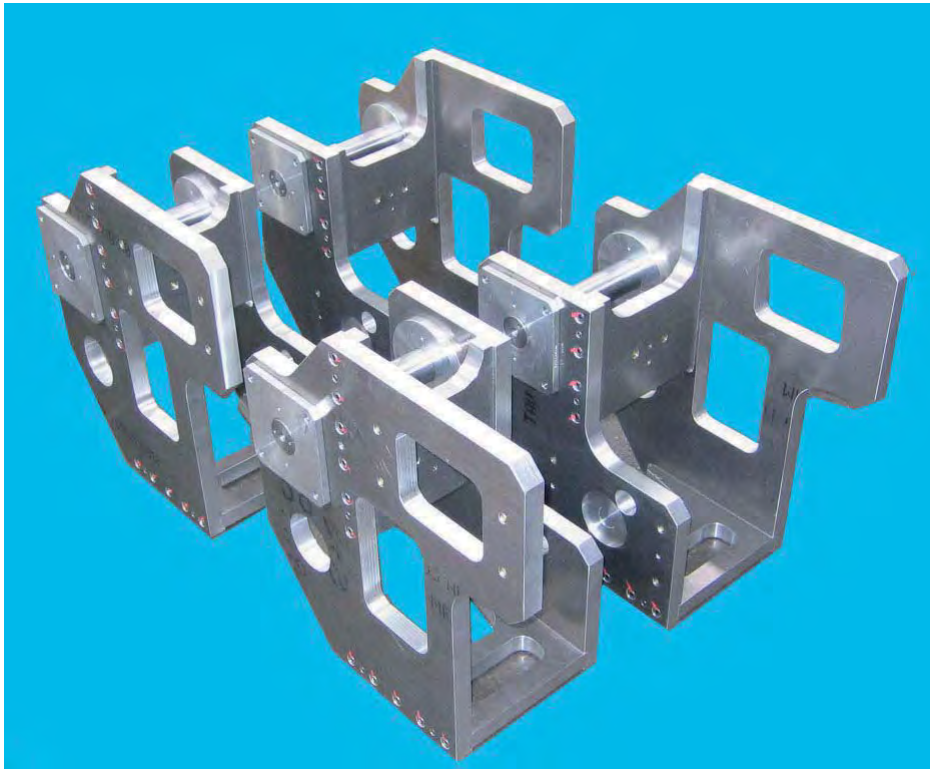
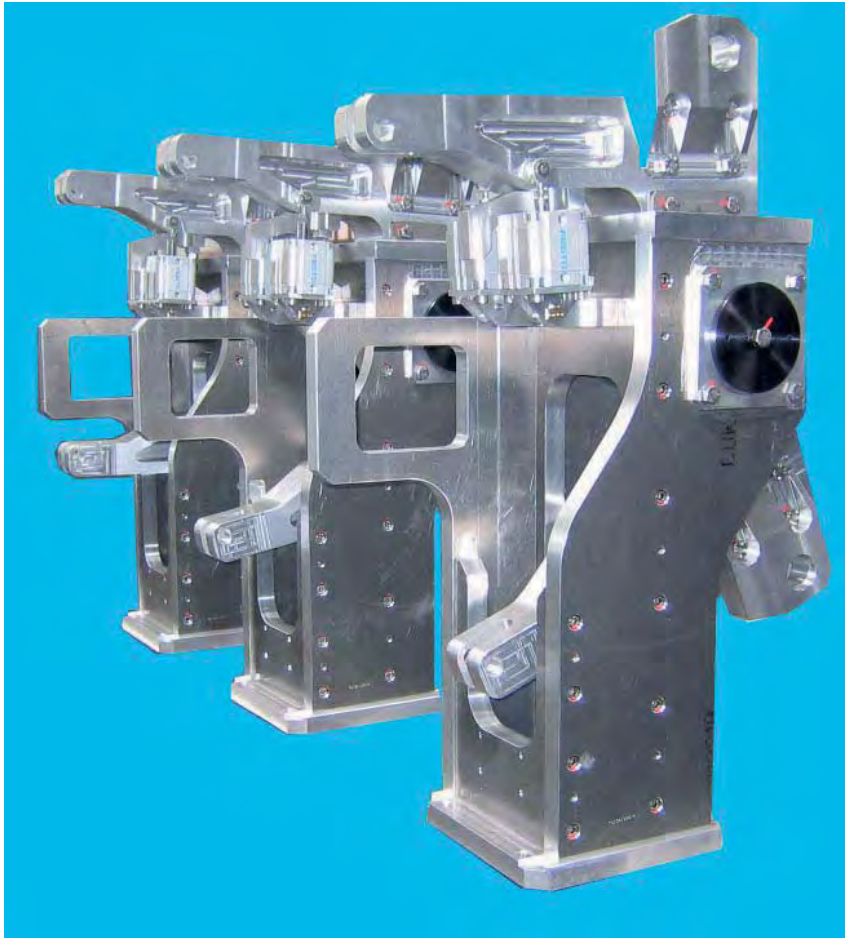

This document is exclusive property of ALESSIO (I). Reproduction or use by a third party without written consent of the company is strictly forbidden, according to EC intellectual property and copyright laws.  
Dieses Dokument ist exklusives Eigentum von ALESSIO (I). Reproduktion oder Verwendung durch Dritte ohne schriftliche Zustimmung der Firma ist strikt untersagt, gemäß den EU Gesetzen für Copyrights und geistiges Eigentum.

Ce document est la propriété exclusive de la société ALESSIO (I). La reproduction ou l'utilisation de ce document par des tiers sans une autorisation écrite de la société est interdite selon les lois CE sur la propriété intellectuelle et le copyright.  
Questo documento è proprietà esclusiva del Consorzio ALESSIO (I). Ne è pertanto vietata la riproduzione o l'utilizzo con qualsiasi mezzo senza il consenso del consorzio stesso ai sensi delle leggi CE sulla proprietà intellettuale e sul copyright.

This document is exclusive property of ALESSIO (I). Reproduction or use by a third party without written consent of the company is strictly forbidden, according to EC intellectual property and copyright laws.  
Dieses Dokument ist exklusives Eigentum von ALESSIO (I). Reproduktion oder Verwendung durch Dritte ohne schriftliche Zustimmung der Firma ist strikt untersagt, gemäss den EU Gesetzen für Copyrights und geistiges Eigentum.



Ce document est la propriété exclusive de la société ALESSIO (I). La reproduction ou l'utilisation de ce document par des tiers sans une autorisation écrite de la société est interdite selon les lois CE sur la propriété intellectuelle et le copyright.  
Questo documento è proprietà esclusiva del Consorzio ALESSIO (I). Ne è pertanto vietata la riproduzione o l'utilizzo con qualsiasi mezzo senza il consenso del consorzio stesso ai sensi delle leggi CE sulla proprietà intellettuale e sul copyright.



# Technical details of Standard Robot Flanges

This document is exclusive property of ALESSIO (I). Reproduction or use by a third party without written consent of the company is strictly forbidden, according to EC intellectual property and copyright laws.  
Dieses Dokument ist exklusives Eigentum von ALESSIO (I). Reproduktion oder Verwendung durch Dritte ohne schriftliche Zustimmung der Firma ist strikt untersagt, gemäß den EU Gesetzen für Copyrights und geistiges Eigentum.

Ce document est la propriété exclusive de la société ALESSIO (I). La reproduction ou l'utilisation de ce document par des tiers sans une autorisation écrite de la société est interdite selon les lois CE sur la propriété intellectuelle et le copyright.  
Questo documento è proprietà esclusiva del Consorzio ALESSIO (I). Ne è pertanto vietata la riproduzione o l'utilizzo con qualsiasi mezzo senza il consenso del consorzio stesso ai sensi delle leggi CE sulla proprietà intellettuale e sul copyright.

## Standard Flange to the robot

This scheme shows the standard flange we use to fix the mounting plate to the robot flange.

It is possible use other types of flange to fit Customer's requirement.

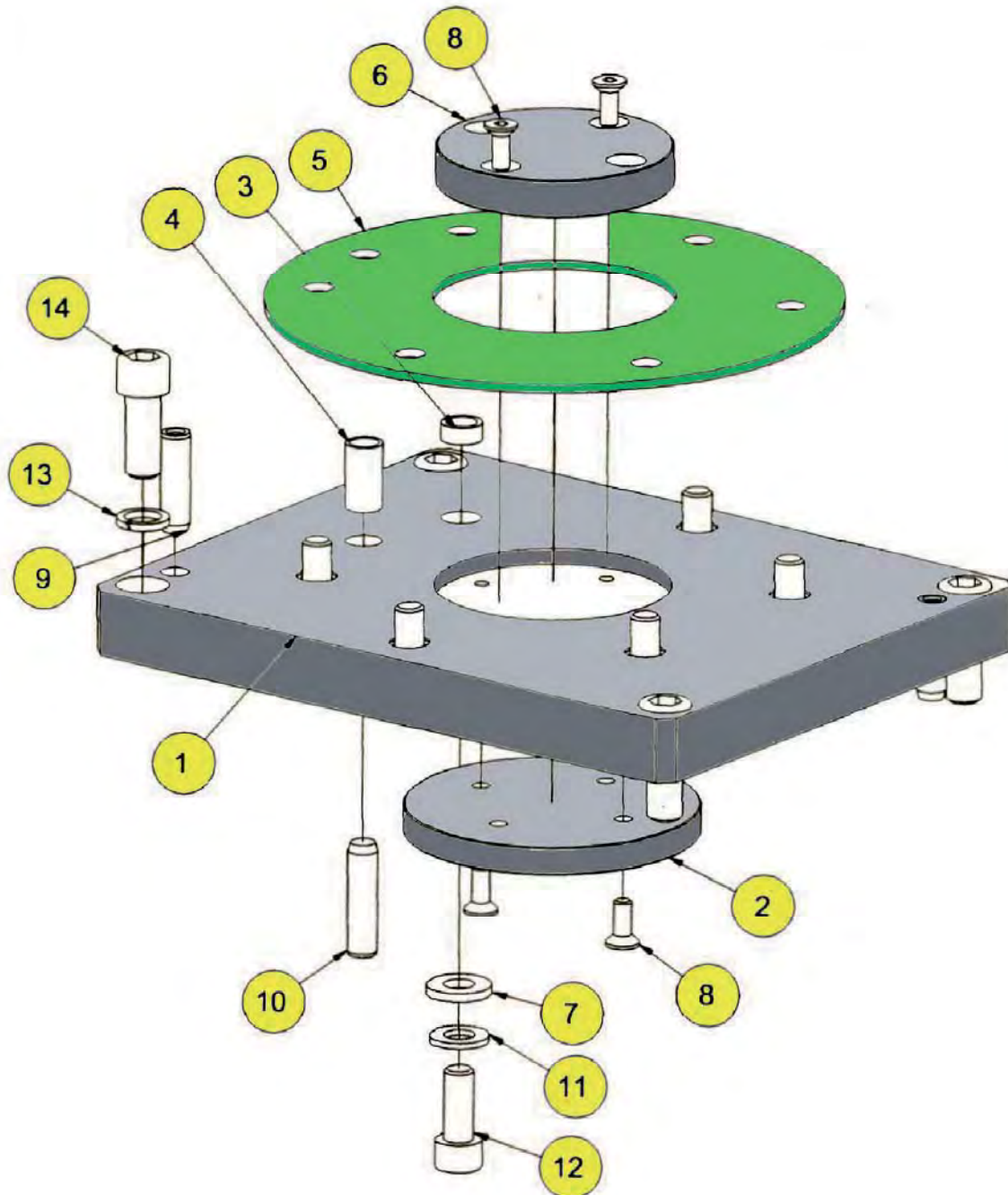

This document is exclusive property of ALESSIO (I). Reproduction or use by a third party without written consent of the company is strictly forbidden, according to EC intellectual property and copyright laws.  
Dieses Dokument ist exklusives Eigentum von ALESSIO (I). Reproduktion oder Verwendung durch Dritte ohne schriftliche Zustimmung der Firma ist strikt untersagt, gemäß den EU Gesetzen für Copyrights und geistiges Eigentum.

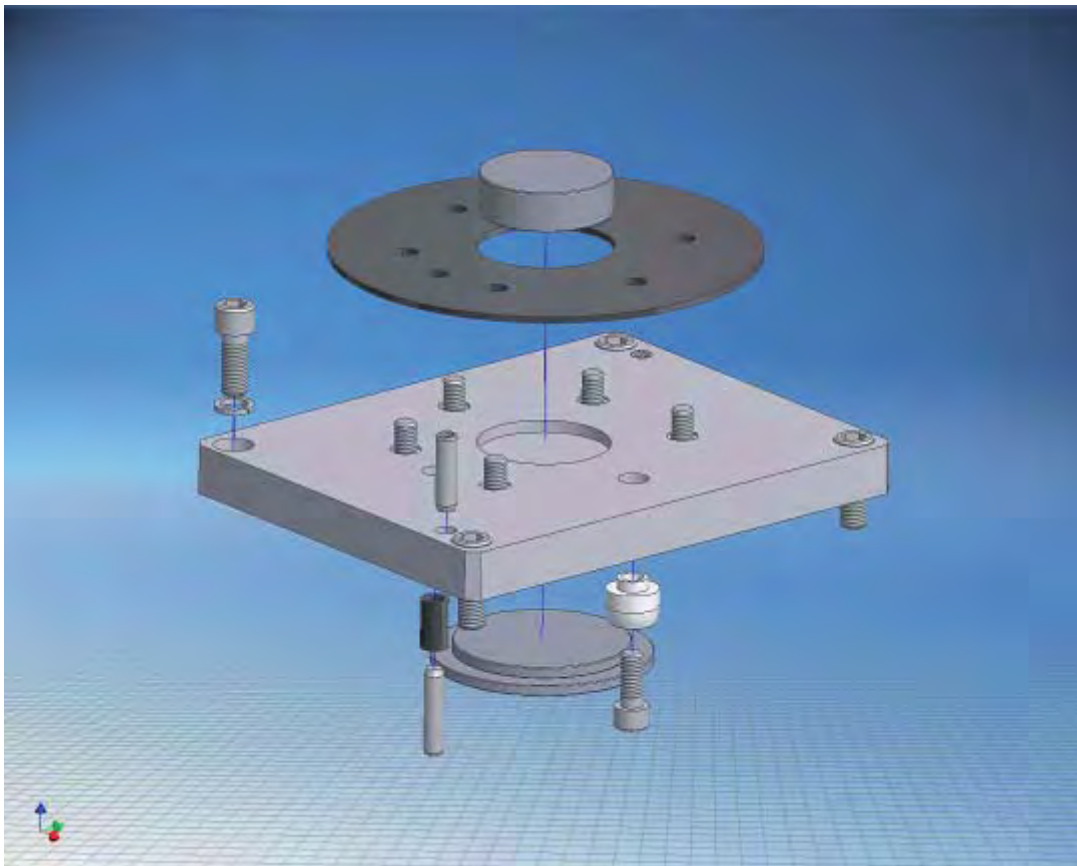
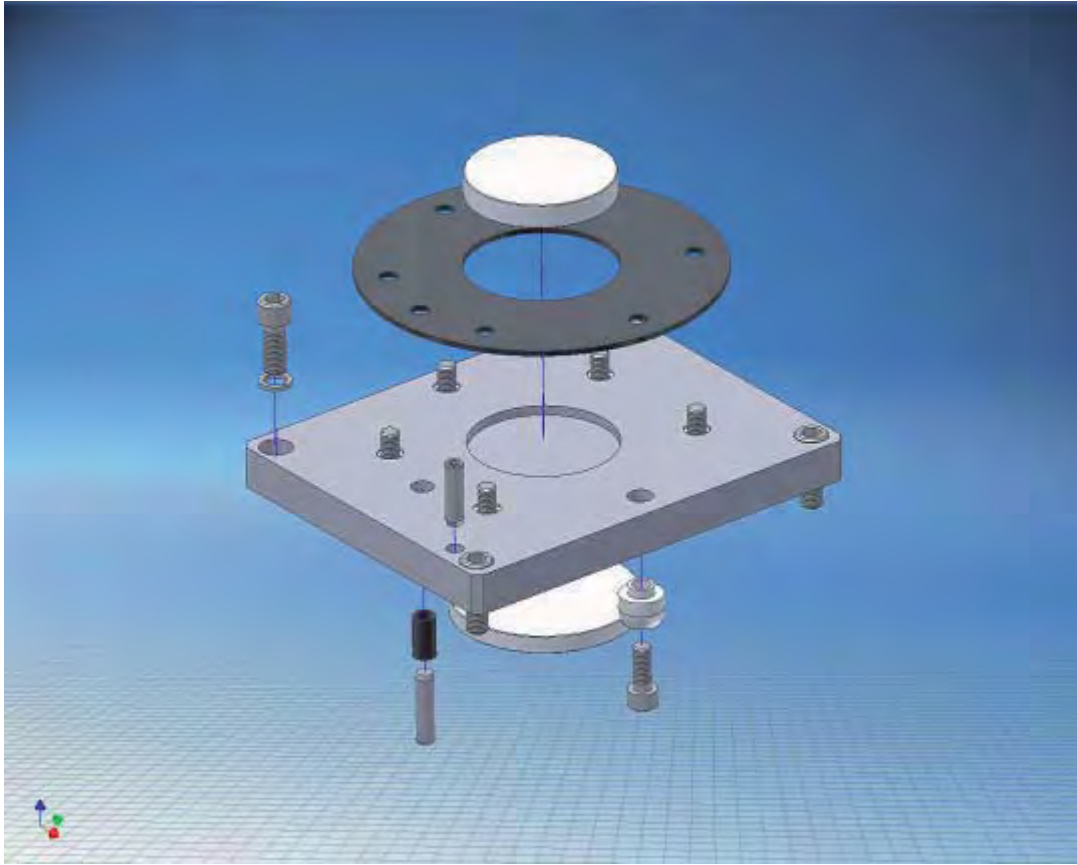

Ce document est la propriété exclusive de la société ALESSIO (I). La reproduction ou l'utilisation de ce document par des tiers sans une autorisation écrite de la société est interdite selon les lois CE sur la propriété intellectuelle et le copyright.  
Questo documento è proprietà esclusiva del Consorzio ALESSIO (I). Ne è pertanto vietata la riproduzione o l'utilizzo con qualsiasi mezzo senza il consenso del consorzio stesso ai sensi delle leggi CE sulla proprietà intellettuale e sul copyright.



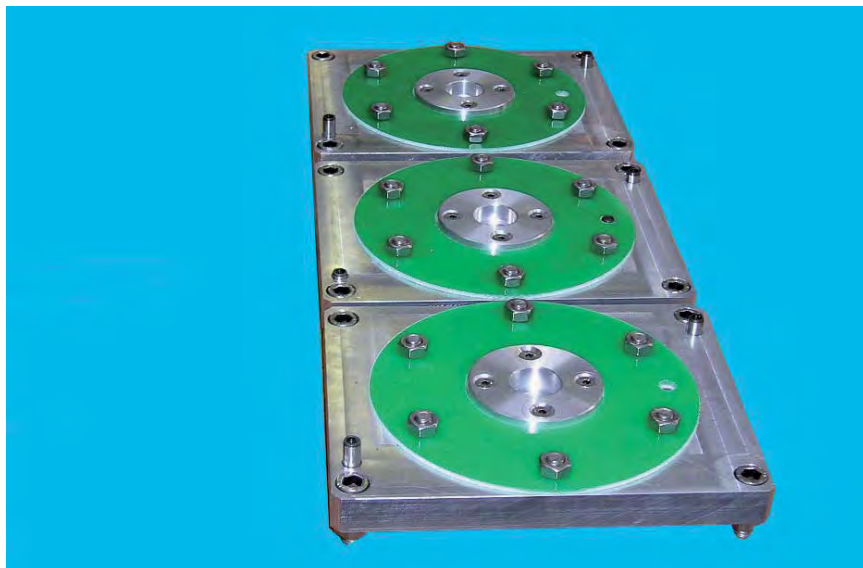
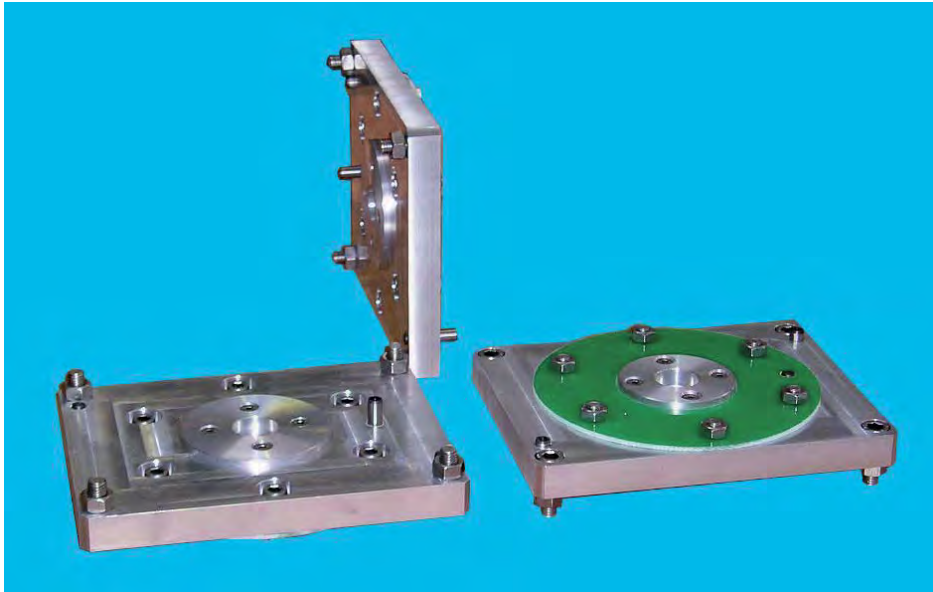

This document is exclusive property of ALESSIO (I). Reproduction or use by a third party without written consent of the company is strictly forbidden, according to EC intellectual property and copyright laws.  
Dieses Dokument ist exklusives Eigentum von ALESSIO (I). Reproduktion oder Verwendung durch Dritte ohne schriftliche Zustimmung der Firma ist strikt untersagt, gemäß den EU Gesetzen für Copyrights und geistiges Eigentum.

Ce document est la propriété exclusive de la société ALESSIO (I). La reproduction ou l'utilisation de ce document par des tiers sans une autorisation écrite de la société est interdite selon les lois CE sur la propriété intellectuelle et le copyright.  
Questo documento è proprietà esclusiva del Consorzio ALESSIO (I). Ne è pertanto vietata la riproduzione o l'utilizzo con qualsiasi mezzo senza il consenso del consorzio stesso ai sensi delle leggi CE sulla proprietà intellettuale e sul copyright.

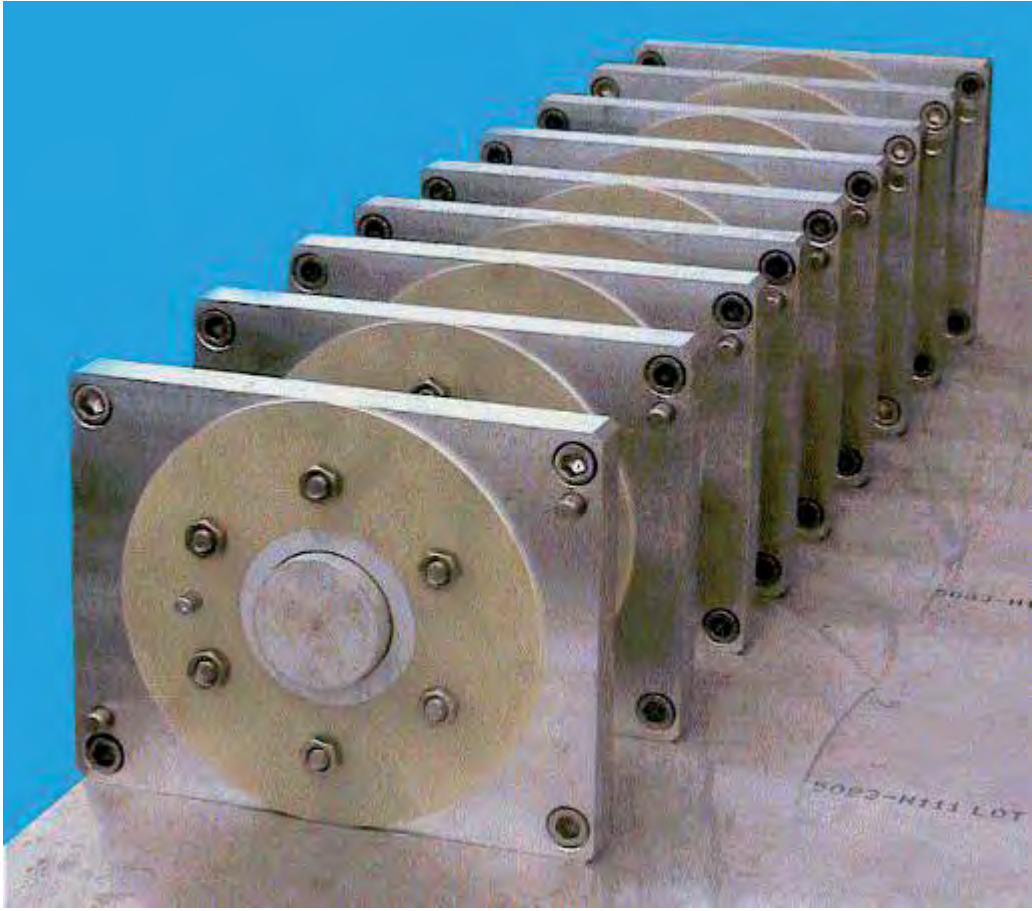

This document is exclusive property of ALESSIO (I). Reproduction or use by a third party without written consent of the company is strictly forbidden, according to EC intellectual property and copyright laws.  
Dieses Dokument ist exklusives Eigentum von ALESSIO (I). Reproduktion oder Verwendung durch Dritte ohne schriftliche Zustimmung der Firma ist strikt untersagt, gemäß den EU-Gesetzen für Copyrights und geistiges Eigentum.

Ce document est la propriété exclusive de la société ALESSIO (I). La reproduction ou l'utilisation de ce document par des tiers sans une autorisation écrite de la société est interdite selon les lois CE sur la propriété intellectuelle et le copyright.  
Questo documento è proprietà esclusiva del Consorzio ALESSIO (I). Ne è pertanto vietata la riproduzione o l'utilizzo con qualsiasi mezzo senza il consenso del consorzio stesso ai sensi delle leggi CE sulla proprietà intellettuale e sul copyright.



# Rapid Manual Gun – Changers

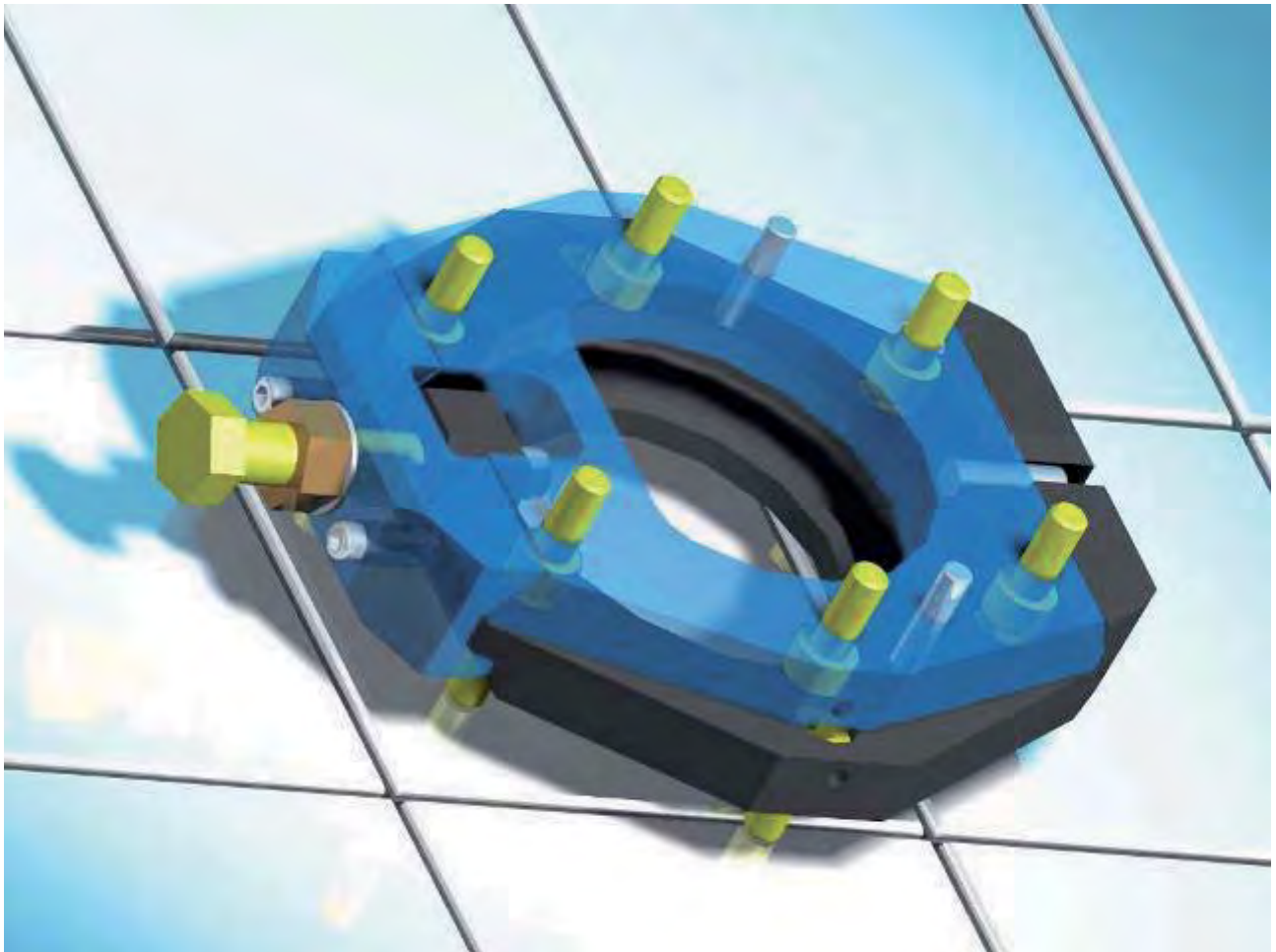

This document is exclusive property of ALESSIO (I). Reproduction or use by a third party without written consent of the company is strictly forbidden, according to EC intellectual property and copyright laws.  
Dieses Dokument ist exklusives Eigentum von ALESSIO (I). Reproduktion oder Verwendung durch Dritte ohne schriftliche Zustimmung der Firma ist strikt untersagt, gemäß den EU Gesetzen für Copyrights und geistiges Eigentum.

Ce document est la propriété exclusive de la société ALESSIO (I). La reproduction ou l'utilisation de ce document par des tiers sans une autorisation écrite de la société est interdite selon les lois CE sur la propriété intellectuelle et le copyright.  
Questo documento è proprietà esclusiva del Consorzio ALESSIO (I). Ne è pertanto vietata la riproduzione o l'utilizzo con qualsiasi mezzo senza il consenso del consorzio stesso ai sensi delle leggi CE sulla proprietà intellettuale e sul copyright.





This document is exclusive property of ALESSIO (I). Reproduction or use by a third party without written consent of the company is strictly forbidden, according to EC intellectual property and copyright laws.  
Dieses Dokument ist exklusives Eigentum von ALESSIO (I). Reproduktion oder Verwendung durch Dritte ohne schriftliche Zustimmung der Firma ist strikt untersagt, gemäß den EU Gesetzen für Copyrights und geistiges Eigentum.

Ce document est la propriété exclusive de la société ALESSIO (I). La reproduction ou l'utilisation de ce document par des tiers sans une autorisation écrite de la société est interdite selon les lois CE sur la propriété intellectuelle et le copyright.  
Questo documento è proprietà esclusiva del Consorzio ALESSIO (I). Ne è pertanto vietata la riproduzione o l'utilizzo con qualsiasi mezzo senza il consenso del consorzio stesso ai sensi delle leggi CE sulla proprietà intellettuale e sul copyright.

This document is exclusive property of ALESSIO (I). Reproduction or use by a third party without written consent if the company is strictly forbidden, according to EC intellectual property and copyright laws.  
Dieses Dokument ist exclusives Eigentum von ALESSIO (I). Reproduktion oder Verwendung durch Dritte ohne schriftliche Zustimmung der Firma ist strikt untersagt, gemäß den EU Gesetzen für Copyrights und geistiges Eigentum.

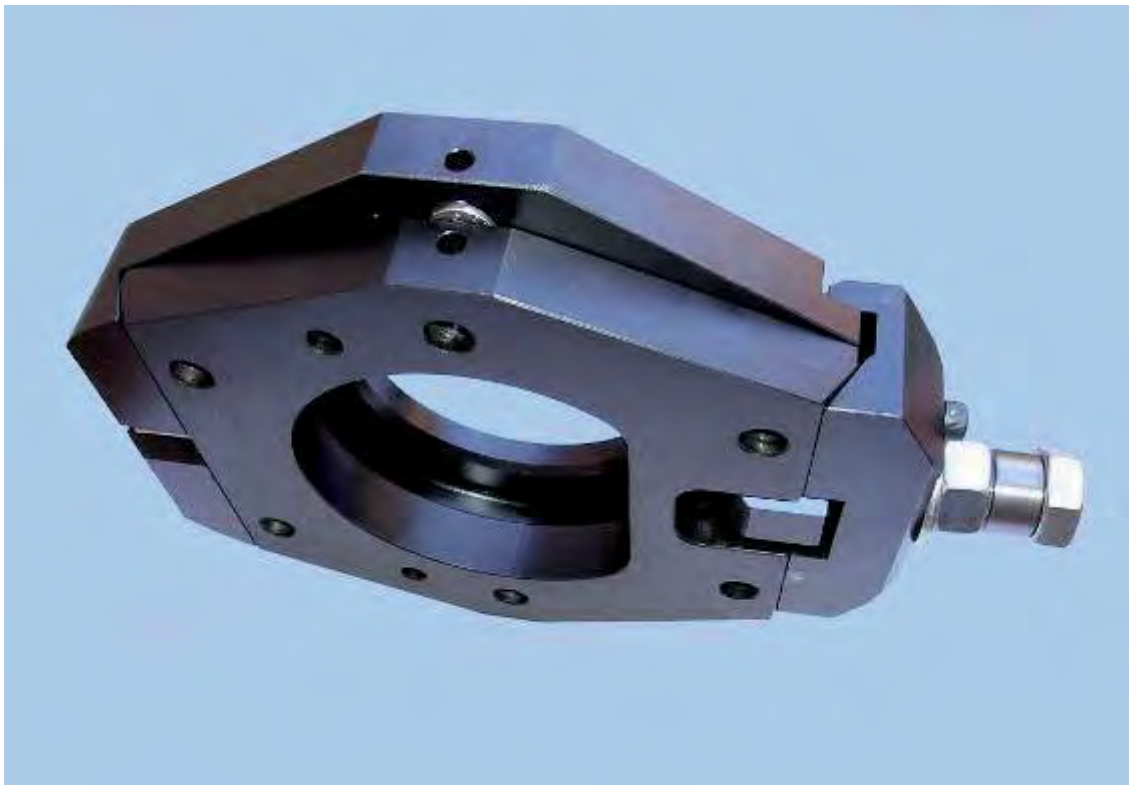

Ce document est la propriété exclusive de la société ALESSIO (I). La reproduction ou l'utilisation de ce document par des tiers sans une autorisation écrite de la société est interdite selon les lois CE sur la propriété intellectuelle et le copyright.  
Questo documento è proprietà esclusiva del Consorzio ALESSIO (I). Ne è pertanto vietata la riproduzione o l'utilizzo con qualsiasi mezzo senza il consenso del consorzio stesso ai sensi delle leggi CE sulla proprietà intellettuale e sul copyright.

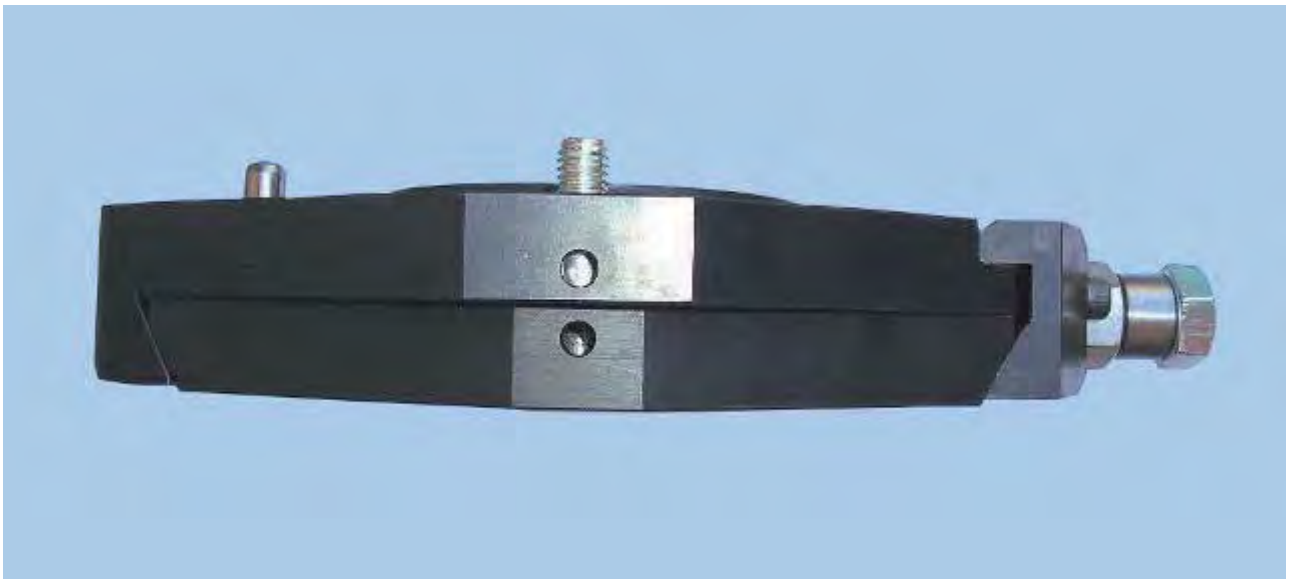

This document is exclusive property of ALESSIO (I). Reproduction or use by a third party without written consent of the company is strictly forbidden, according to EC intellectual property and copyright laws.  
Dieses Dokument ist exklusives Eigentum von ALESSIO (I). Reproduktion oder Verwendung durch Dritte ohne schriftliche Zustimmung der Firma ist strikt untersagt, gemäß den EU Gesetzen für Copyrights und geistiges Eigentum.

Ce document est la propriété exclusive de la société ALESSIO (I). La reproduction ou l'utilisation de ce document par des tiers sans une autorisation écrite de la société est interdite selon les lois CE sur la propriété intellectuelle et le copyright.  
Questo documento è proprietà esclusiva del Consorzio ALESSIO (I). Ne è pertanto vietata la riproduzione o l'utilizzo con qualsiasi mezzo senza il consenso del consorzio stesso ai sensi delle leggi CE sulla proprietà intellettuale e sul copyright.



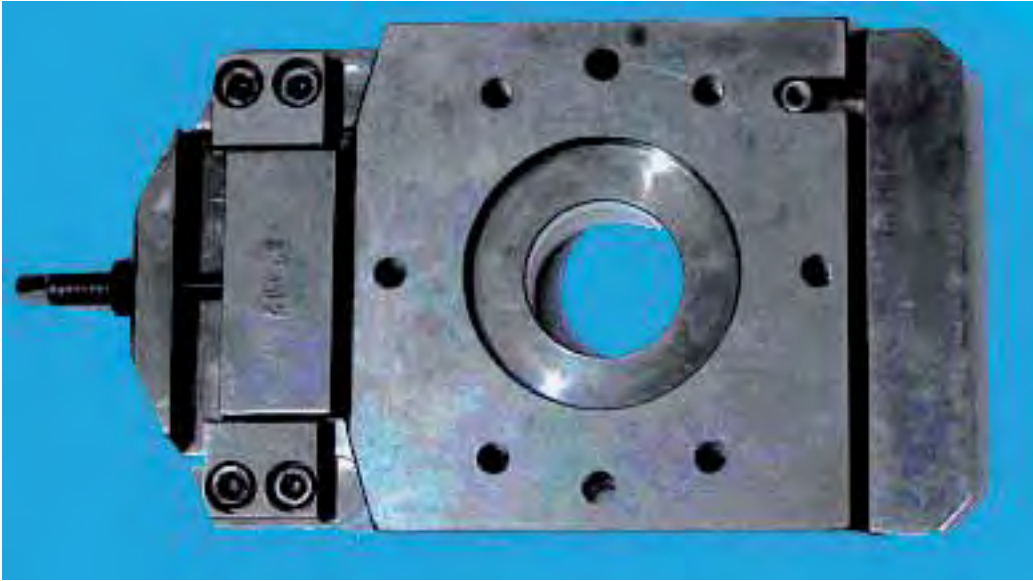

This document is exclusive property of ALESSIO (I). Reproduction or use by a third party without written consent of the company is strictly forbidden, according to EC intellectual property and copyright laws.  
Dieses Dokument ist exklusives Eigentum von ALESSIO (I). Reproduktion oder Verwendung durch Dritte ohne schriftliche Zustimmung der Firma ist strikt untersagt, gemäß den EU-Gesetzen für Copyrights und geistiges Eigentum.

Ce document est la propriété exclusive de la société ALESSIO (I). La reproduction ou l'utilisation de ce document par des tiers sans une autorisation écrite de la société est interdite selon les lois CE sur la propriété intellectuelle et le copyright.  
Questo documento è proprietà esclusiva del Consorzio ALESSIO (I). Ne è pertanto vietata la riproduzione o l'utilizzo con qualsiasi mezzo senza il consenso del consorzio stesso ai sensi delle leggi CE sulla proprietà intellettuale e sul copyright.

# PROTECTION COVERS

Our LARGE Guns can be delivered (on request) with protection sacks against weld sparks, fire and dust.

They are studied for each type of gun, depending on the shape and length of arms.

We memorize the model of each one: this will allow in the future to make spares of any cover, just mentioning the drawing No of the gun.

Each cover has front, upper, lower and lateral openings for inspection and some open zones for air cooling.



This document is exclusive property of ALESSIO (I). Reproduction or use by a third party without written consent of the company is strictly forbidden, according to EC intellectual property and copyright laws. Dieses Dokument ist exklusives Eigentum von ALESSIO (I). Reproduktion oder Verwendung durch Dritte ohne schriftliche Zustimmung der Firma ist strikt untersagt, gemäß den EU-Gesetzen für Copyrights und geistiges Eigentum.

Ce document est la propriété exclusive de la société ALESSIO (I). La reproduction ou l'utilisation de ce document par des tiers sans une autorisation écrite de la société est interdite selon les lois CE sur la propriété intellectuelle et le copyright. Questo documento è proprietà esclusiva del Consorzio ALESSIO (I). Ne è pertanto vietata la riproduzione o l'utilizzo con qualsiasi mezzo senza il consenso del consorzio stesso ai sensi della legge CE sulla proprietà intellettuale e sul copyright.

# Machine and hand reamers for Electrode CONES



To re-machine cones of electrode-holders and to retouch the surface of cones holding the electrodes here are gross and fine reamers, that can be used on drilling or milling machines or lathes. Both of them have a hole, so water cooling tubes can be left in place during the dressing operation.

The operator can retouch the cone on the electrode-holder without dismounting components from the machine, the gun or the robot. These tools are essential and simple means for a preventive maintenance program, to guarantee always the same degree of conductivity to areas bringing the current to electrodes.

In fact all cones holding the electrodes are subject to a high density of current and often to improper mechanical action of the operator. These tools are improving both weld process and electrode-holder life.



This document is exclusive property of ALESSIO (I). Reproduction or use by a third party without written consent of the company is strictly forbidden, according to EC intellectual property and copyright laws. Dieses Dokument ist exclusives Eigentum von ALESSIO (I). Reproduktion oder Verwendung durch Dritte ohne schriftliche Zustimmung der Firma ist strikt untersagt, gemäss den EU Gesetzen für Copyrights und geistiges Eigentum.



Ce document est la propriété exclusive de la société ALESSIO (I). La reproduction ou l'utilisation de ce document par des tiers sans une autorisation écrite de la société est interdite selon les lois CE sur la propriété intellectuelle et le copyright. Questo documento è proprietà esclusiva del Consorzio ALESSIO (I). Ne è pertanto vietata la riproduzione o l'utilizzo con qualsiasi mezzo senza il consenso del consorzio stesso ai sensi delle leggi CE sulla proprietà intellettuale e sul copyright.

# Technical details of Standard Packing Crates

This document is exclusive property of ALESSIO (I). Reproduction or use by a third party without written consent of the company is strictly forbidden, according to EC intellectual property and copyright laws.  
Dieses Dokument ist exklusives Eigentum von ALESSIO (I). Reproduktion oder Verwendung durch Dritte ohne schriftliche Zustimmung der Firma ist strikt untersagt, gemäß den EU Gesetzen für Copyrights und geistiges Eigentum.

Ce document est la propriété exclusive de la société ALESSIO (I). La reproduction ou l'utilisation de ce document par des tiers sans une autorisation écrite de la société est interdite selon les lois CE sur la propriété intellectuelle et le copyright.  
Questo documento è proprietà esclusiva del Consorzio ALESSIO (I). Ne è pertanto vietata la riproduzione o l'utilizzo con qualsiasi mezzo senza il consenso del consorzio stesso ai sensi delle leggi CE sulla proprietà intellettuale e sul copyright.

This document is exclusive property of ALESSIO (I). Reproduction or use by a third party without written consent of the company is strictly forbidden, according to EC intellectual property and copyright laws. Dieses Dokument ist exklusives Eigentum von ALESSIO (I). Reproduktion oder Verwendung durch Dritte ohne schriftliche Zustimmung der Firma ist strikt untersagt, gemäß den EU Gesetzen für Copyrights und geistiges Eigentum.



Ce document est la propriété exclusive de la société ALESSIO (I). La reproduction ou l'utilisation de ce document par des tiers sans une autorisation écrite de la société est interdite selon les lois CE sur la propriété intellectuelle et le copyright. Questo documento è proprietà esclusiva del Consorzio ALESSIO (I). Ne è pertanto vietata la riproduzione o l'utilizzo con qualsiasi mezzo senza il consenso del consorzio stesso ai sensi delle leggi CE sulla proprietà intellettuale e sul copyright.



# Pneumatics, water circuit & electr. connections

This document is exclusive property of ALESSIO (I). Reproduction or use by a third party without written consent of the company is strictly forbidden, according to EC intellectual property and copyright laws.  
Dieses Dokument ist exklusives Eigentum von ALESSIO (I). Reproduktion oder Verwendung durch Dritte ohne schriftliche Zustimmung der Firma ist strikt untersagt, gemäss den EU Gesetzen für Copyrights und geistiges Eigentum.

Ce document est la propriété exclusive de la société ALESSIO (I). La reproduction ou l'utilisation de ce document par des tiers sans une autorisation écrite de la société est interdite selon les lois CE sur la propriété intellectuelle et le copyright.  
Questo documento è proprietà esclusiva del Consorzio ALESSIO (I). Ne è pertanto vietata la riproduzione o l'utilizzo con qualsiasi mezzo senza il consenso del consorzio stesso ai sensi delle leggi CE sulla proprietà intellettuale e sul copyright.

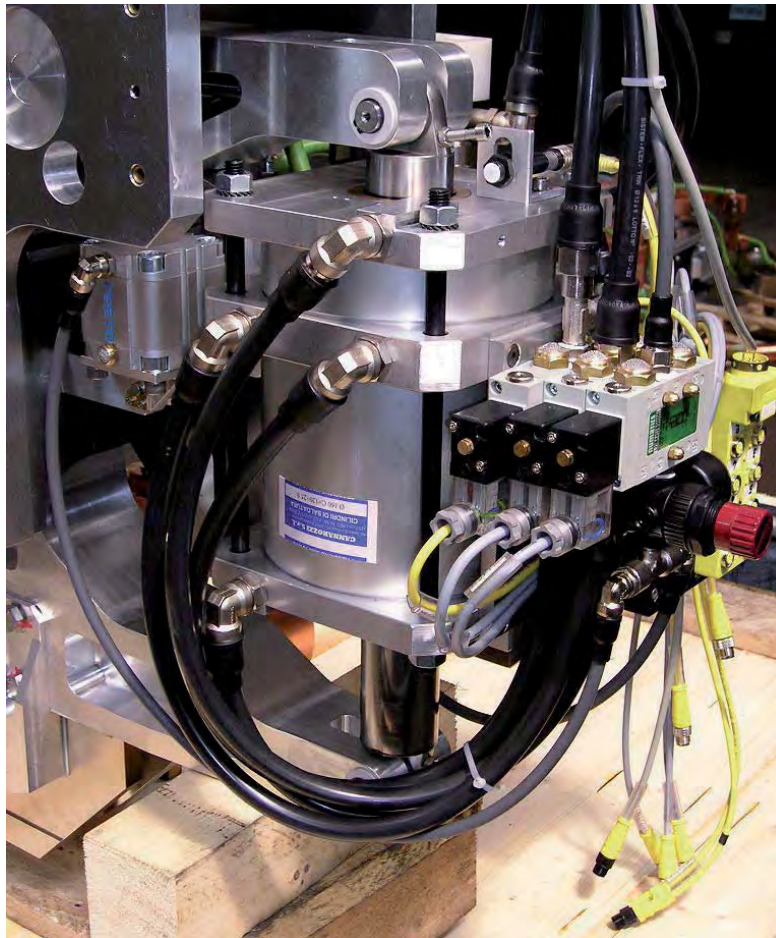
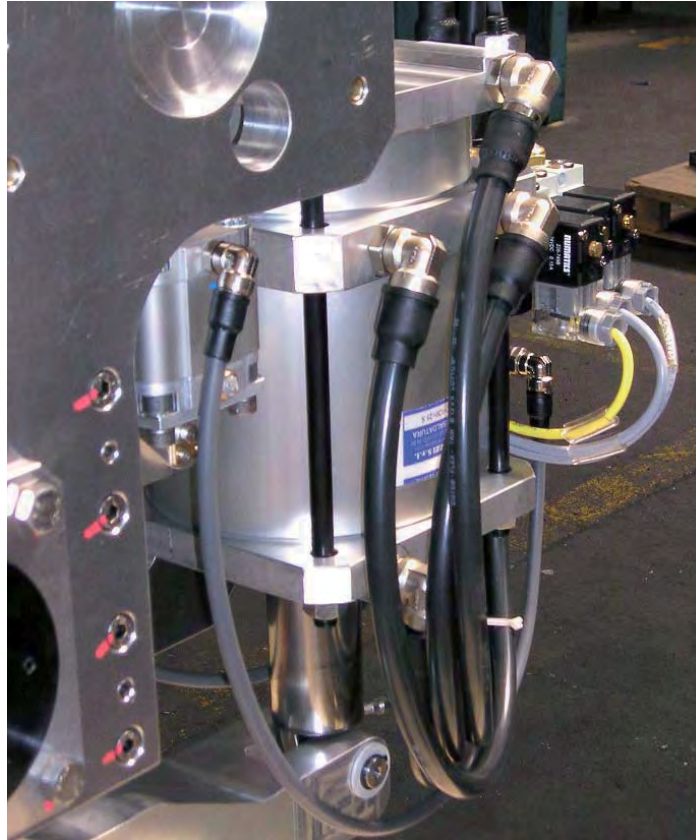

This document is exclusive property of ALESSIO (I). Reproduction or use by a third party without written consent of the company is strictly forbidden, according to EC intellectual property and copyright laws. Dieses Dokument ist exklusives Eigentum von ALESSIO (I). Reproduktion oder Verwendung durch Dritte ohne schriftliche Zustimmung der Firma ist strikt untersagt, gemäß den EU Gesetzen für Copyrights und geistiges Eigentum.

Ce document est la propriété exclusive de la société ALESSIO (I). La reproduction ou l'utilisation de ce document par des tiers sans une autorisation écrite de la société est interdite selon les lois CE sur la propriété intellectuelle et le copyright. Questo documento è proprietà esclusiva del Consorzio ALESSIO (I). Ne è pertanto vietata la riproduzione o l'utilizzo con qualsiasi mezzo senza il consenso del consorzio stesso ai sensi delle leggi CE sulla proprietà intellettuale e sul copyright.



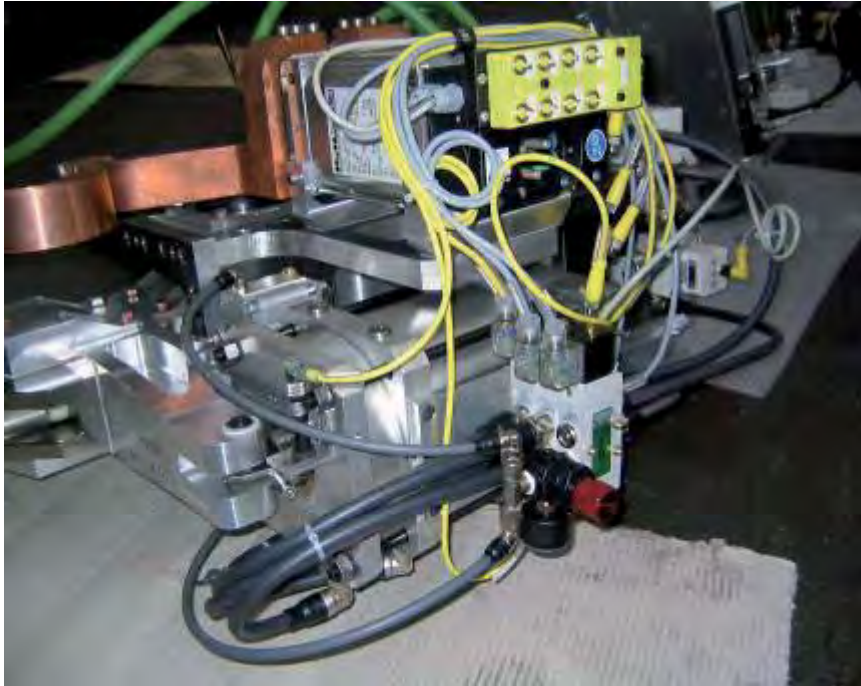

This document is exclusive property of ALESSIO (I). Reproduction or use by a third party without written consent of the company is strictly forbidden, according to EC intellectual property and copyright laws. Dieses Dokument ist exklusives Eigentum von ALESSIO (I). Reproduktion oder Verwendung durch Dritte ohne schriftliche Zustimmung der Firma ist strikt untersagt, gemäß den EU Gesetzen für Copyrights und geistiges Eigentum.

Ce document est la propriété exclusive de la société ALESSIO (I). La reproduction ou l'utilisation de ce document par des tiers sans une autorisation écrite de la société est interdite selon les lois CE sur la propriété intellectuelle et le copyright. Questo documento è proprietà esclusiva del Consorzio ALESSIO (I). Ne è pertanto vietata la riproduzione o l'utilizzo con qualsiasi mezzo senza il consenso del consorzio stesso ai sensi delle leggi CE sulla proprietà intellettuale e sul copyright.



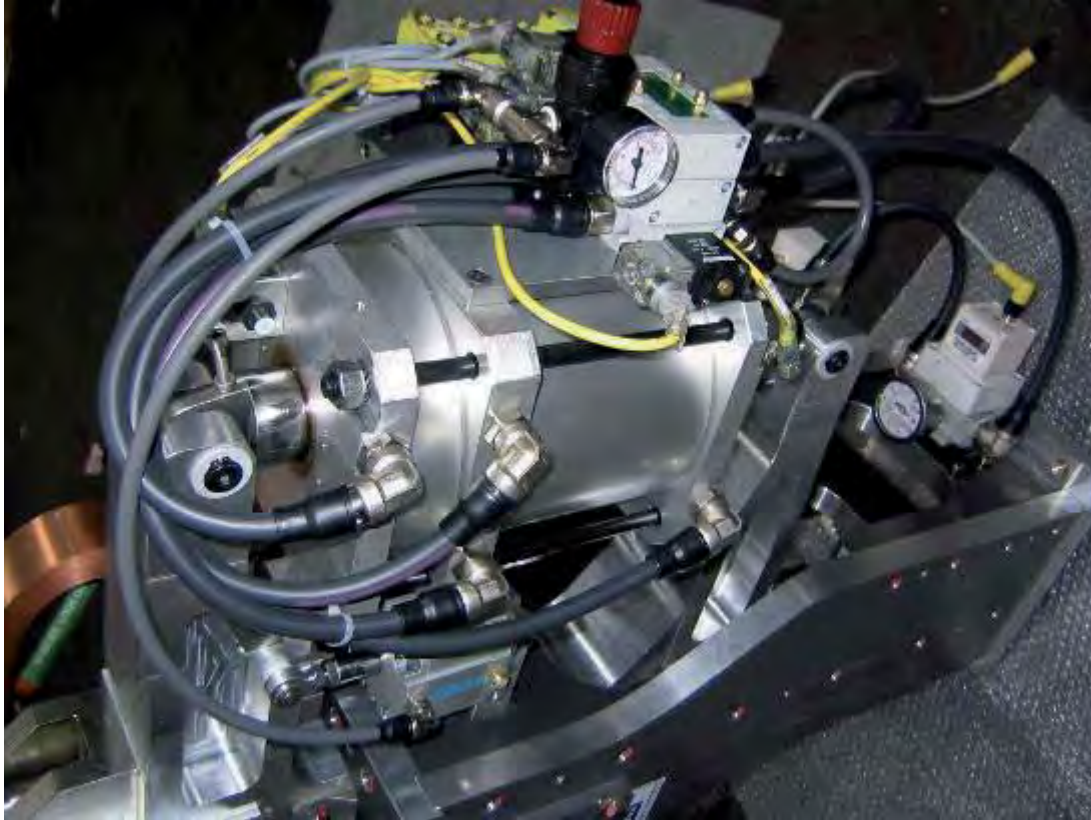

This document is exclusive property of ALESSIO (I). Reproduction or use by a third party without written consent of the company is strictly forbidden, according to EC intellectual property and copyright laws.  
Dieses Dokument ist exklusives Eigentum von ALESSIO (I). Reproduktion oder Verwendung durch Dritte ohne schriftliche Zustimmung der Firma ist strikt untersagt, gemäß den EU-Gesetzen für Copyrights und geistiges Eigentum.

Ce document est la propriété exclusive de la société ALESSIO (I). La reproduction ou l'utilisation de ce document par des tiers sans une autorisation écrite de la société est interdite selon les lois CE sur la propriété intellectuelle et le copyright.  
Questo documento è proprietà esclusiva del Consorzio ALESSIO (I). Ne è pertanto vietata la riproduzione o l'utilizzo con qualsiasi mezzo senza il consenso del consorzio stesso ai sensi delle leggi CE sulla proprietà intellettuale e sul copyright.

This document is exclusive property of ALESSIO (I). Reproduction or use by a third party without written consent of the company is strictly forbidden, according to EC intellectual property and copyright laws.  
Dieses Dokument ist exklusives Eigentum von ALESSIO (I). Reproduktion oder Verwendung durch Dritte ohne schriftliche Zustimmung der Firma ist strikt untersagt, gemäß den EU Gesetzen für Copyrights und geistiges Eigentum.

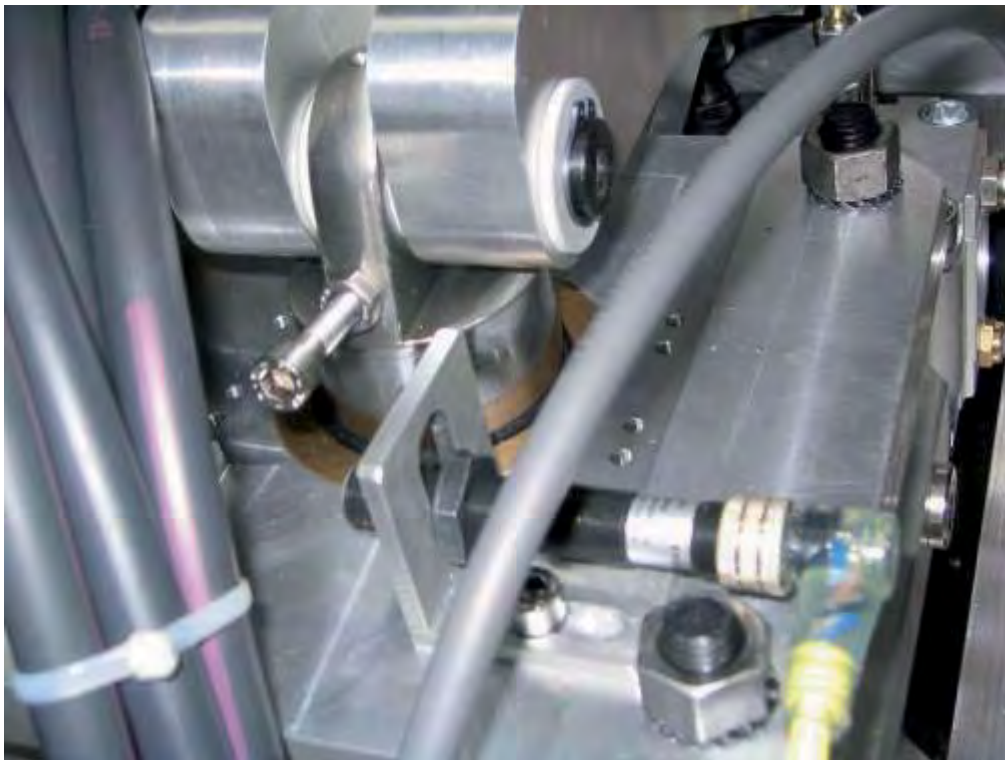
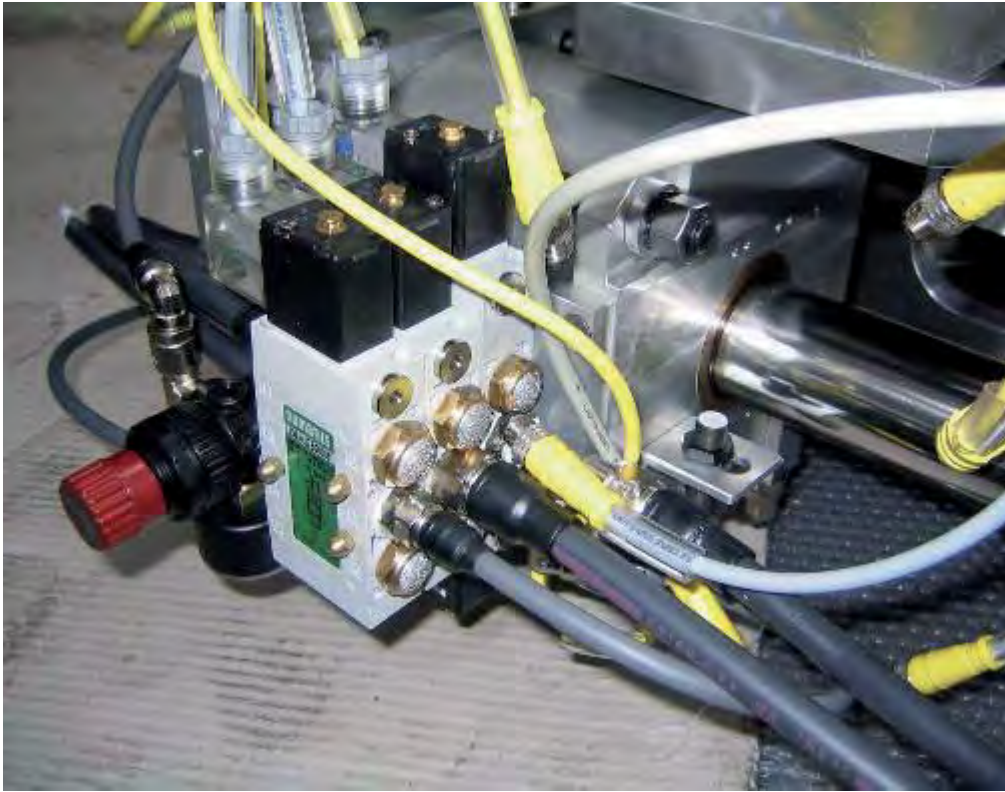

Ce document est la propriété exclusive de la société ALESSIO (I). La reproduction ou l'utilisation de ce document par des tiers sans une autorisation écrite de la société est interdite selon les lois CE sur la propriété intellectuelle et le copyright.  
Questo documento è proprietà esclusiva del Consorzio ALESSIO (I). Ne è pertanto vietata la riproduzione o l'utilizzo con qualsiasi mezzo senza il consenso del consorzio stesso ai sensi delle leggi CE sulla proprietà intellettuale e sul copyright.



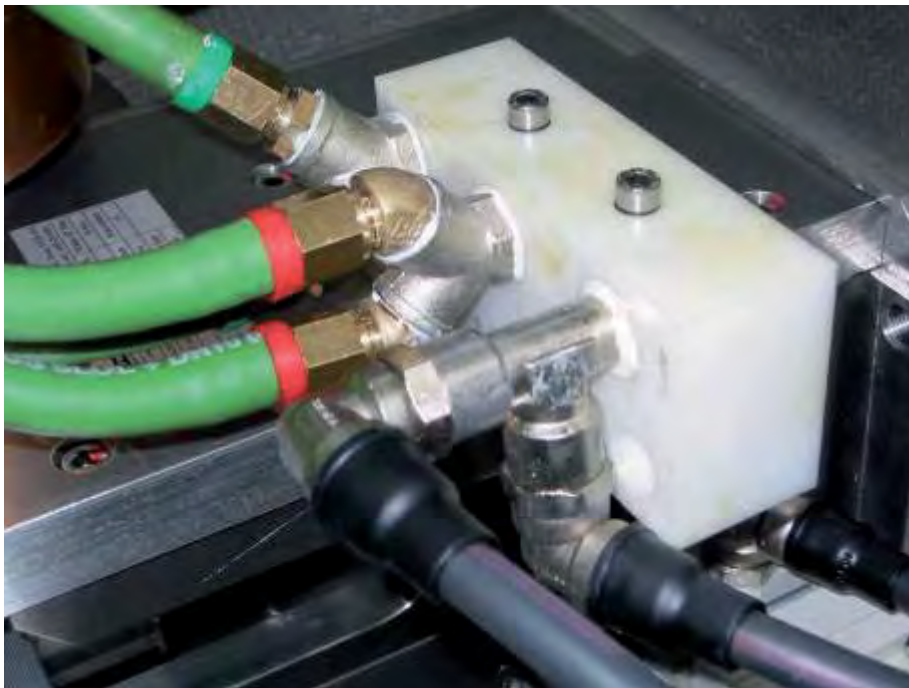

This document is exclusive property of ALESSIO (I). Reproduction or use by a third party without written consent of the company is strictly forbidden, according to EC intellectual property and copyright laws. Dieses Dokument ist exklusives Eigentum von ALESSIO (I). Reproduktion oder Verwendung durch Dritte ohne schriftliche Zustimmung der Firma ist strikt untersagt, gemäß den EU-Gesetzen für Copyrights und geistiges Eigentum.

Ce document est la propriété exclusive de la société ALESSIO (I). La reproduction ou l'utilisation de ce document par des tiers sans une autorisation écrite de la société est interdite selon les lois CE sur la propriété intellectuelle et le copyright. Questo documento è proprietà esclusiva del Consorzio ALESSIO (I). Ne è pertanto vietata la riproduzione o l'utilizzo con qualsiasi mezzo senza il consenso del consorzio stesso ai sensi delle leggi CE sulla proprietà intellettuale e sul copyright.



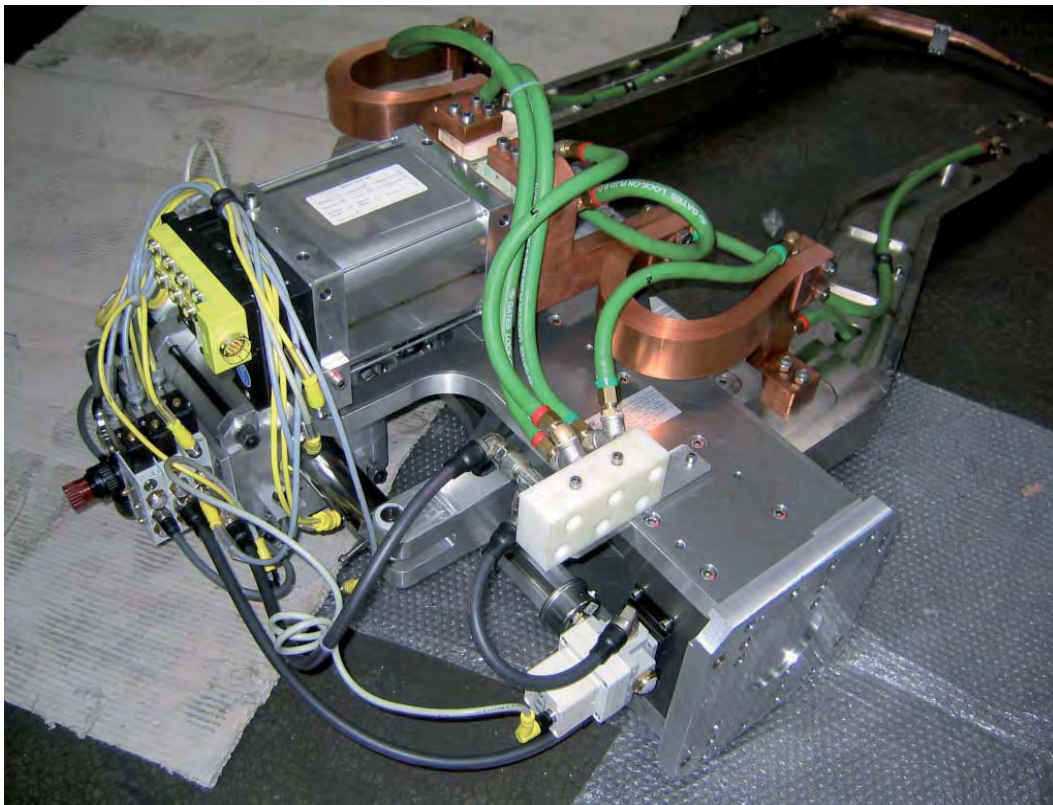

This document is exclusive property of ALESSIO (I). Reproduction or use by a third party without written consent of the company is strictly forbidden, according to EC intellectual property and copyright laws. Dieses Dokument ist exklusives Eigentum von ALESSIO (I). Reproduktion oder Verwendung durch Dritte ohne schriftliche Zustimmung der Firma ist strikt untersagt, gemäß den EU Gesetzen für Copyrights und geistiges Eigentum.

Ce document est la propriété exclusive de la société ALESSIO (I). La reproduction ou l'utilisation de ce document par des tiers sans une autorisation écrite de la société est interdite selon les lois CE sur la propriété intellectuelle et le copyright. Questo documento è proprietà esclusiva del Consorzio ALESSIO (I). Ne è pertanto vietata la riproduzione o l'utilizzo con qualsiasi mezzo senza il consenso del consorzio stesso ai sensi delle leggi CE sulla proprietà intellettuale e sul copyright.

This document is exclusive property of ALESSIO (I). Reproduction or use by a third party without written consent if the company is strictly forbidden, according to EC intellectual property and copyright laws.  
Dieses Dokument ist exklusives Eigentum von ALESSIO (I). Reproduktion oder Verwendung durch Dritte ohne schriftliche Zustimmung der Firma ist strikt untersagt, gemäß den EU Gesetzen für Copyrights und geistiges Eigentum.

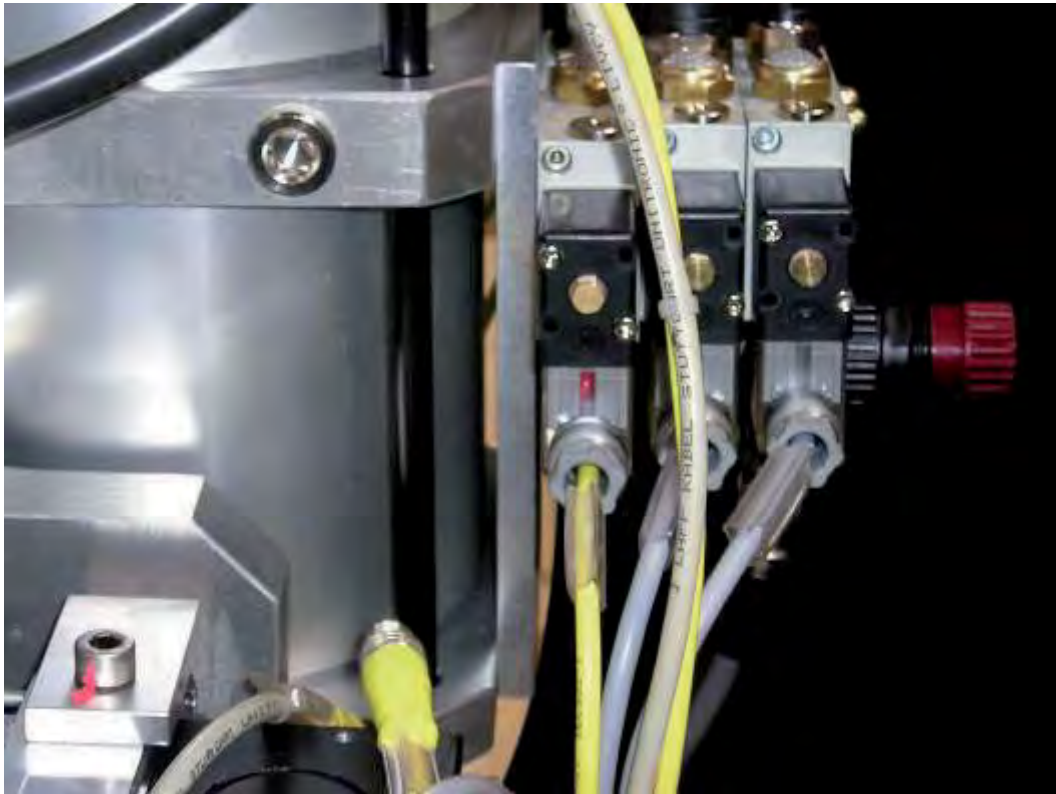

Ce document est la propriété exclusive de la société ALESSIO (I). La reproduction ou l'utilisation de ce document par des tiers sans une autorisation écrite de la société est interdite selon les lois CE sur la propriété intellectuelle et le copyright.  
Questo documento è proprietà esclusiva del Consorzio ALESSIO (I). Ne è pertanto vietata la riproduzione o l'utilizzo con qualsiasi mezzo senza il consenso del consorzio stesso ai sensi delle leggi CE sulla proprietà intellettuale e sul copyright.



# Assembly Facilities in Italy

This document is exclusive property of ALESSIO (I). Reproduction or use by a third party without written consent of the company is strictly forbidden, according to EC intellectual property and copyright laws.  
Dieses Dokument ist exklusives Eigentum von ALESSIO (I). Reproduktion oder Verwendung durch Dritte ohne schriftliche Zustimmung der Firma ist strikt untersagt, gemäß den EU Gesetzen für Copyrights und geistiges Eigentum.

Ce document est la propriété exclusive de la société ALESSIO (I). La reproduction ou l'utilisation de ce document par des tiers sans une autorisation écrite de la société est interdite selon les lois CE sur la propriété intellectuelle et le copyright.  
Questo documento è proprietà esclusiva del Consorzio ALESSIO (I). Ne è pertanto vietata la riproduzione o l'utilizzo con qualsiasi mezzo senza il consenso del consorzio stesso ai sensi delle leggi CE sulla proprietà intellettuale e sul copyright.



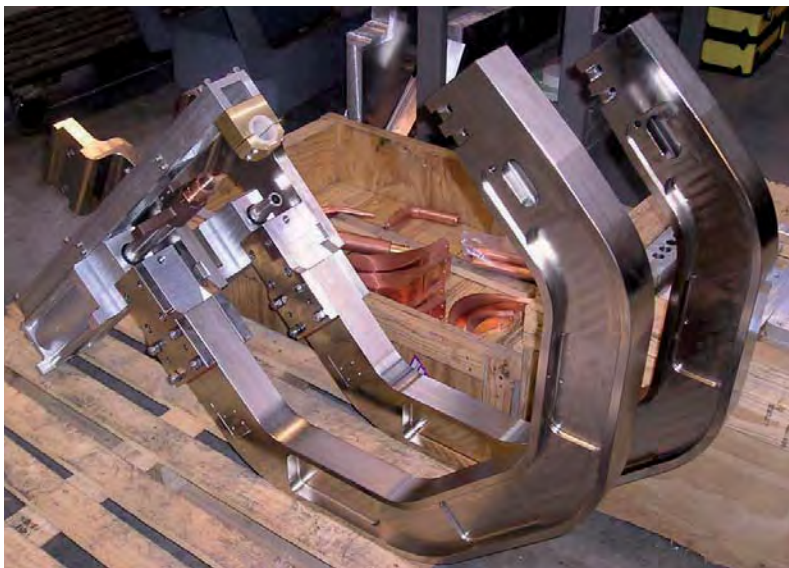

This document is exclusive property of ALESSIO (I). Reproduction or use by a third party without written consent of the company is strictly forbidden, according to EC intellectual property and copyright laws. Dieses Dokument ist exklusives Eigentum von ALESSIO (I). Reproduktion oder Verwendung durch Dritte ohne schriftliche Zustimmung der Firma ist strikt untersagt, gemäß den EU-Gesetzen für Copyrights und geistiges Eigentum.

Ce document est la propriété exclusive de la société ALESSIO (I). La reproduction ou l'utilisation de ce document par des tiers sans une autorisation écrite de la société est interdite selon les lois CE sur la propriété intellectuelle et le copyright. Questo documento è proprietà esclusiva del Consorzio ALESSIO (I). Ne è pertanto vietata la riproduzione o l'utilizzo con qualsiasi mezzo senza il consenso del consorzio stesso ai sensi delle leggi CE sulla proprietà intellettuale e sul copyright.



## Assembly Facilities in TRINO (Italy)



This document is exclusive property of ALESSIO (I). Reproduction or use by a third party without written consent of the company is strictly forbidden, according to EC intellectual property and copyright laws.  
Dieses Dokument ist exklusives Eigentum von ALESSIO (I). Reproduktion oder Verwendung durch Dritte ohne schriftliche Zustimmung der Firma ist strikt untersagt, gemäß den EU Gesetzen für Copyrights und geistiges Eigentum.

Ce document est la propriété exclusive de la société ALESSIO (I). La reproduction ou l'utilisation de ce document par des tiers sans une autorisation écrite de la société est interdite selon les lois CE sur la propriété intellectuelle et le copyright.  
Questo documento è proprietà esclusiva del Consorzio ALESSIO (I). Ne è pertanto vietata la riproduzione o l'utilizzo con qualsiasi mezzo senza il consenso del consorzio stesso ai sensi delle leggi CE sulla proprietà intellettuale e sul copyright.



This document is exclusive property of ALESSIO (I). Reproduction or use by a third party without written consent of the company is strictly forbidden, according to EC intellectual property and copyright laws.  
Dieses Dokument ist exklusives Eigentum von ALESSIO (I). Reproduktion oder Verwendung durch Dritte ohne schriftliche Zustimmung der Firma ist strikt untersagt, gemäß den EU Gesetzen für Copyrights und geistiges Eigentum.

Ce document est la propriété exclusive de la société ALESSIO (I). La reproduction ou l'utilisation de ce document par des tiers sans une autorisation écrite de la société est interdite selon les lois CE sur la propriété intellectuelle et le copyright.  
Questo documento è proprietà esclusiva del Consorzio ALESSIO (I). Ne è pertanto vietata la riproduzione o l'utilizzo con qualsiasi mezzo senza il consenso del consorzio stesso ai sensi della legge CE sulla proprietà intellettuale e sul copyright.





This document is exclusive property of ALESSIO (I). Reproduction or use by a third party without written consent of the company is strictly forbidden, according to EC intellectual property and copyright laws.  
Dieses Dokument ist exklusives Eigentum von ALESSIO (I). Reproduktion oder Verwendung durch Dritte ohne schriftliche Zustimmung der Firma ist strikt untersagt, gemäss den EU Gesetzen für Copyrights und geistiges Eigentum.

Ce document est la propriété exclusive de la société ALESSIO (I). La reproduction ou l'utilisation de ce document par des tiers sans une autorisation écrite de la société est interdite selon les lois CE sur la propriété intellectuelle et le copyright.  
Questo documento è proprietà esclusiva del Consorzio ALESSIO (I). Ne è pertanto vietata la riproduzione o l'utilizzo con qualsiasi mezzo senza il consenso del consorzio stesso ai sensi delle leggi CE sulla proprietà intellettuale e sul copyright.





This document is exclusive property of ALESSIO (I). Reproduction or use by a third party without written consent of the company is strictly forbidden, according to EC intellectual property and copyright laws. Dieses Dokument ist exklusives Eigentum von ALESSIO (I). Reproduktion oder Verwendung durch Dritte ohne schriftliche Zustimmung der Firma ist strikt untersagt, gemäß den EU-Gesetzen für Copyrights und geistiges Eigentum.

Ce document est la propriété exclusive de la société ALESSIO (I). La reproduction ou l'utilisation de ce document par des tiers sans une autorisation écrite de la société est interdite selon les lois CE sur la propriété intellectuelle et le copyright. Questo documento è proprietà esclusiva del Consorzio ALESSIO (I). Ne è pertanto vietata la riproduzione o l'utilizzo con qualsiasi mezzo senza il consenso del consorzio stesso ai sensi delle leggi CE sulla proprietà intellettuale e sul copyright.



## Offices in MORANO (Italy)



This document is exclusive property of ALESSIO (I). Reproduction or use by a third party without written consent of the company is strictly forbidden, according to EC intellectual property and copyright laws.  
Dieses Dokument ist exklusives Eigentum von ALESSIO (I). Reproduktion oder Verwendung durch Dritte ohne schriftliche Zustimmung der Firma ist strikt untersagt, gemäß den EU Gesetzen für Copyrights und geistiges Eigentum.

Ce document est la propriété exclusive de la société ALESSIO (I). La reproduction ou l'utilisation de ce document par des tiers sans une autorisation écrite de la société est interdite selon les lois CE sur la propriété intellectuelle et le copyright.  
Questo documento è proprietà esclusiva del Consorzio ALESSIO (I). Ne è pertanto vietata la riproduzione o l'utilizzo con qualsiasi mezzo senza il consenso del consorzio stesso ai sensi delle leggi CE sulla proprietà intellettuale e sul copyright.



# MANUAL and SPECIAL GUNS

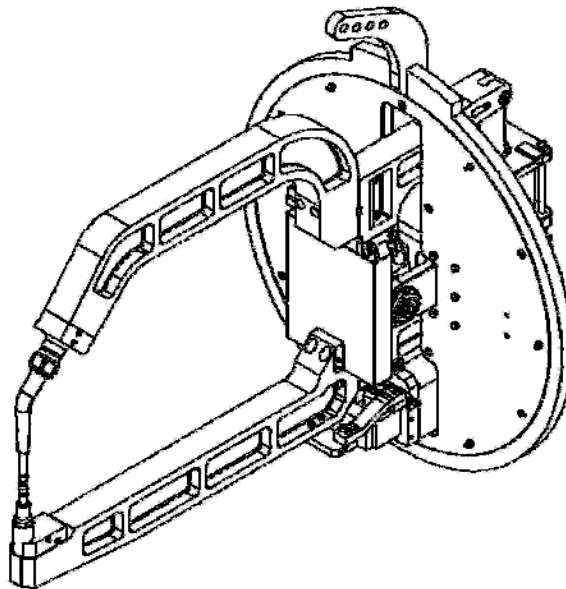
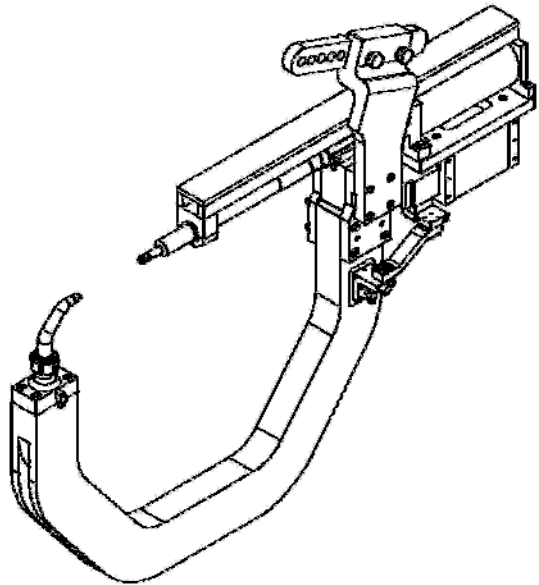
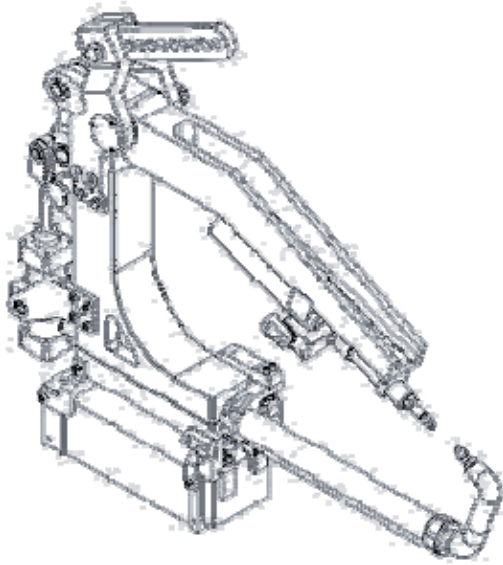

This document is exclusive property of ALESSIO (I). Reproduction or use by a third party without written consent of the company is strictly forbidden, according to EC intellectual property and copyright laws.  
Dieses Dokument ist exklusives Eigentum von ALESSIO (I). Reproduktion oder Verwendung durch Dritte ohne schriftliche Zustimmung der Firma ist strikt untersagt, gemäß den EU Gesetzen für Copyrights und geistiges Eigentum.

Ce document est la propriété exclusive de la société ALESSIO (I). La reproduction ou l'utilisation de ce document par des tiers sans une autorisation écrite de la société est interdite selon les lois CE sur la propriété intellectuelle et le copyright.  
Questo documento è proprietà esclusiva del Consorzio ALESSIO (I). Ne è pertanto vietata la riproduzione o l'utilizzo con qualsiasi mezzo senza il consenso del consorzio stesso ai sensi delle leggi CE sulla proprietà intellettuale e sul copyright.

This document is exclusive property of ALESSIO (I). Reproduction or use by a third party without written consent of the company is strictly forbidden, according to EC intellectual property and copyright laws.  
Dieses Dokument ist exklusives Eigentum von ALESSIO (I). Reproduktion oder Verwendung durch Dritte ohne schriftliche Zustimmung der Firma ist strikt untersagt, gemäß den EU Gesetzen für Copyrights und geistiges Eigentum.

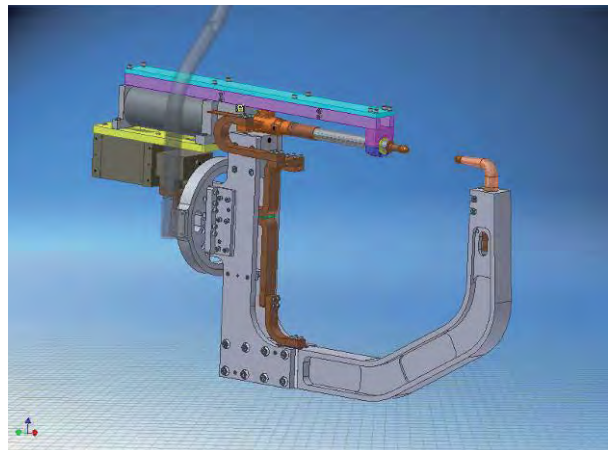
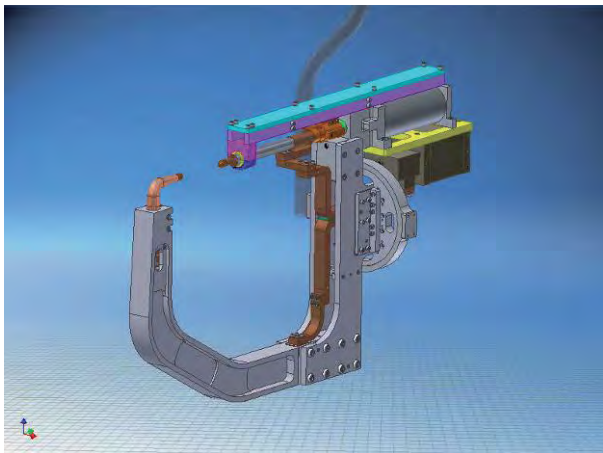
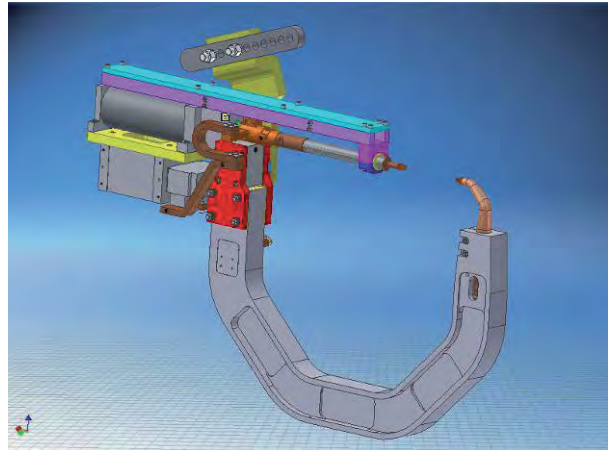
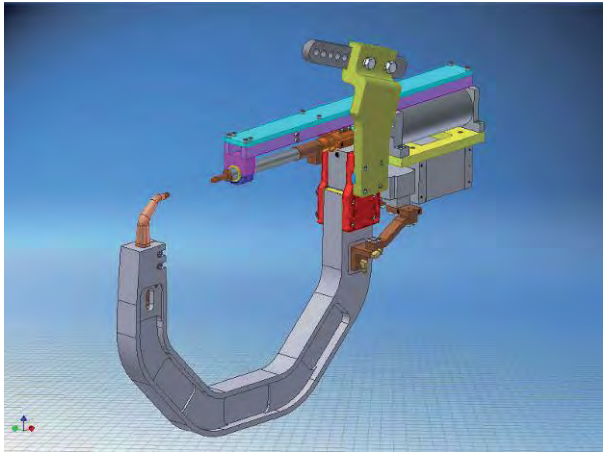

Ce document est la propriété exclusive de la société ALESSIO (I). La reproduction ou l'utilisation de ce document par des tiers sans une autorisation écrite de la société est interdite selon les lois CE sur la propriété intellectuelle et le copyright.  
Questo documento è proprietà esclusiva del Consorzio ALESSIO (I). Ne è pertanto vietata la riproduzione o l'utilizzo con qualsiasi mezzo senza il consenso del consorzio stesso ai sensi delle leggi CE sulla proprietà intellettuale e sul copyright.

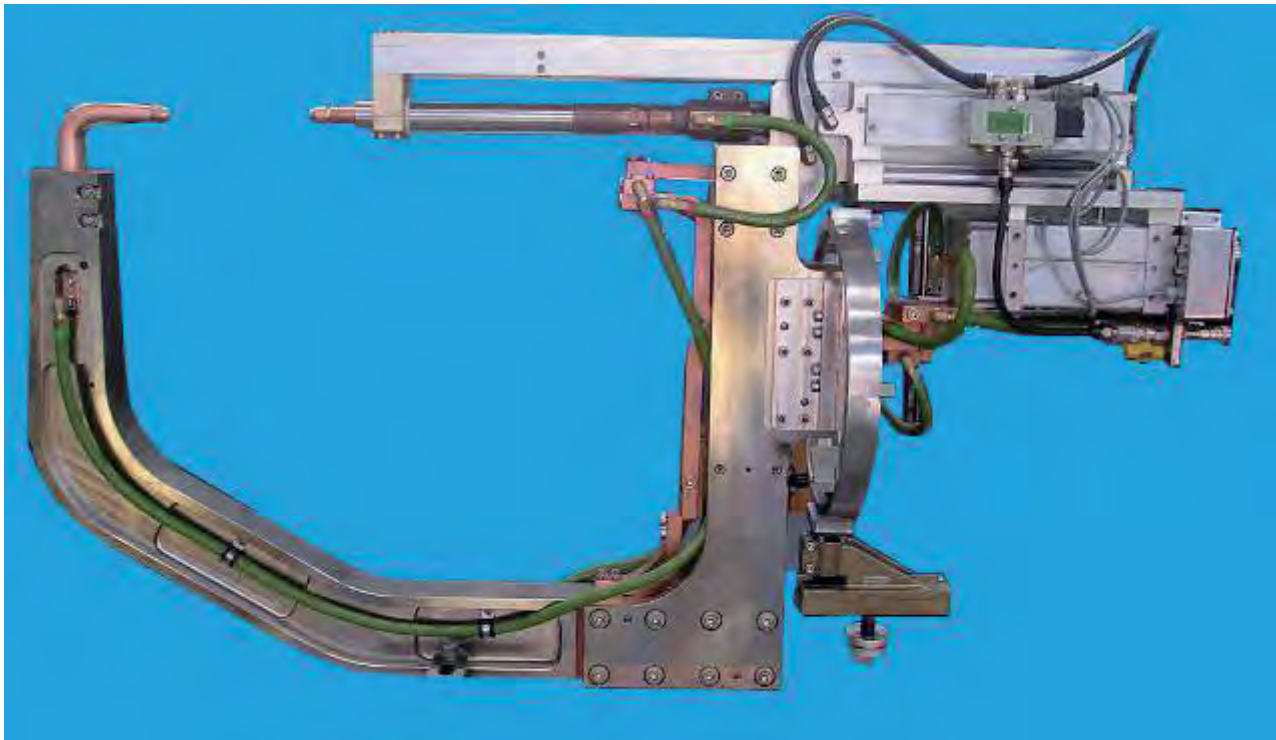
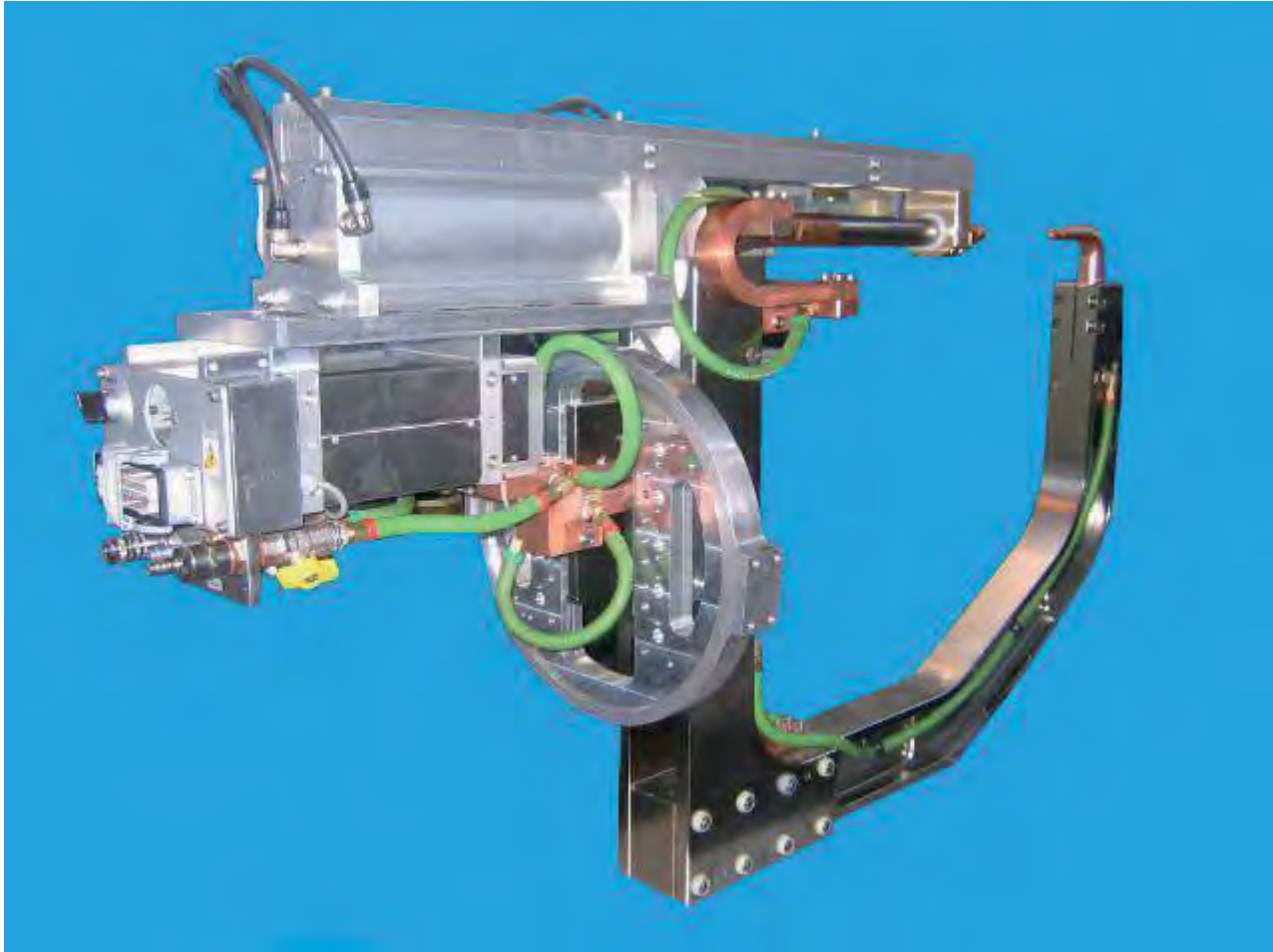

This document is exclusive property of ALESSIO (I). Reproduction or use by a third party without written consent of the company is strictly forbidden, according to EC intellectual property and copyright laws. Dieses Dokument ist exklusives Eigentum von ALESSIO (I). Reproduktion oder Verwendung durch Dritte ohne schriftliche Zustimmung der Firma ist strikt untersagt, gemäß den EU Gesetzen für Copyrights und geistiges Eigentum.

Ce document est la propriété exclusive de la société ALESSIO (I). La reproduction ou l'utilisation de ce document par des tiers sans une autorisation écrite de la société est interdite selon les lois CE sur la propriété intellectuelle et le copyright. Questo documento è proprietà esclusiva del Consorzio ALESSIO (I). Ne è pertanto vietata la riproduzione o l'utilizzo con qualsiasi mezzo senza il consenso del consorzio stesso ai sensi delle leggi CE sulla proprietà intellettuale e sul copyright.



This document is exclusive property of ALESSIO (I). Reproduction or use by a third party without written consent of the company is strictly forbidden, according to EC intellectual property and copyright laws.  
 Dieses Dokument ist exklusives Eigentum von ALESSIO (I). Reproduktion oder Verwendung durch Dritte ohne schriftliche Zustimmung der Firma ist strikt untersagt, gemäß den EU Gesetzen für Copyrights und geistiges Eigentum.

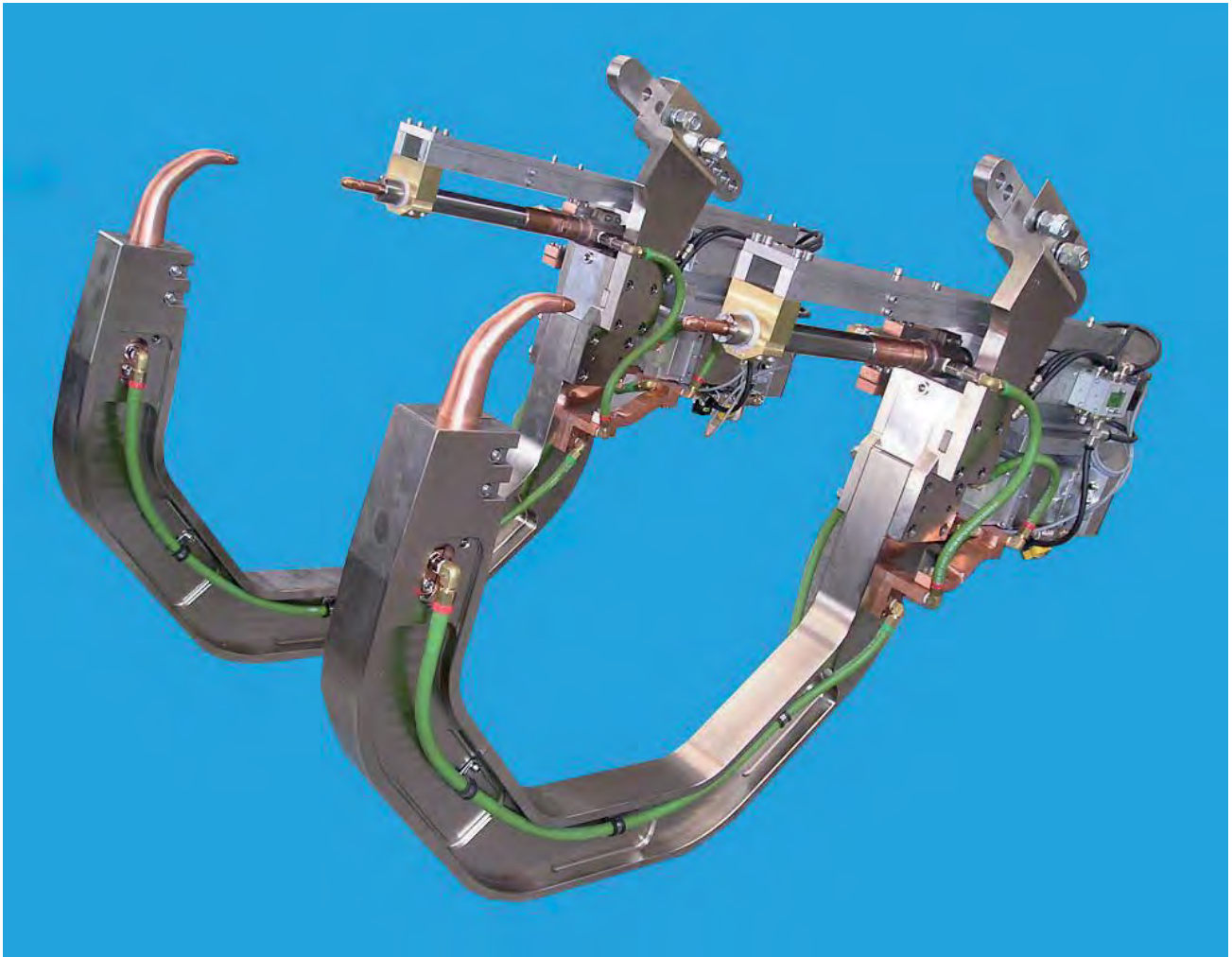

Ce document est la propriété exclusive de la société ALESSIO (I). La reproduction ou l'utilisation de ce document par des tiers sans une autorisation écrite de la société est interdite selon les lois CE sur la propriété intellectuelle et le copyright.  
 Questo documento è proprietà esclusiva del Consorzio ALESSIO (I). Ne è pertanto vietata la riproduzione o l'utilizzo con qualsiasi mezzo senza il consenso del consorzio stesso ai sensi delle leggi CE sulla proprietà intellettuale e sul copyright.

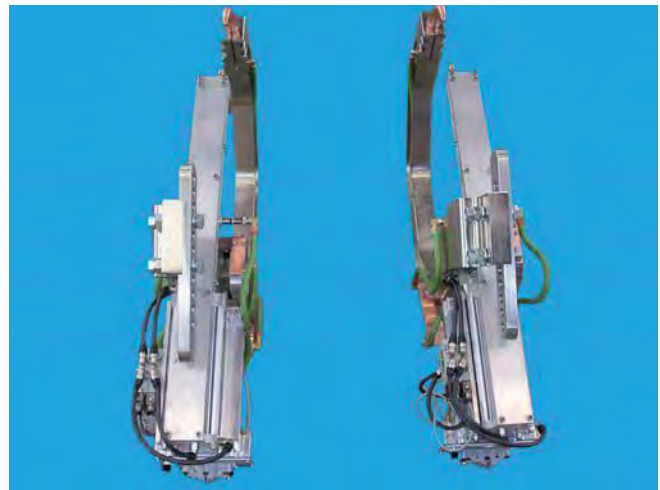
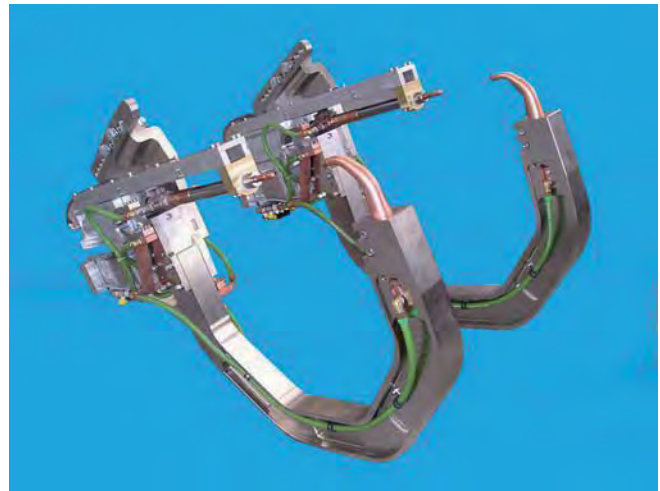
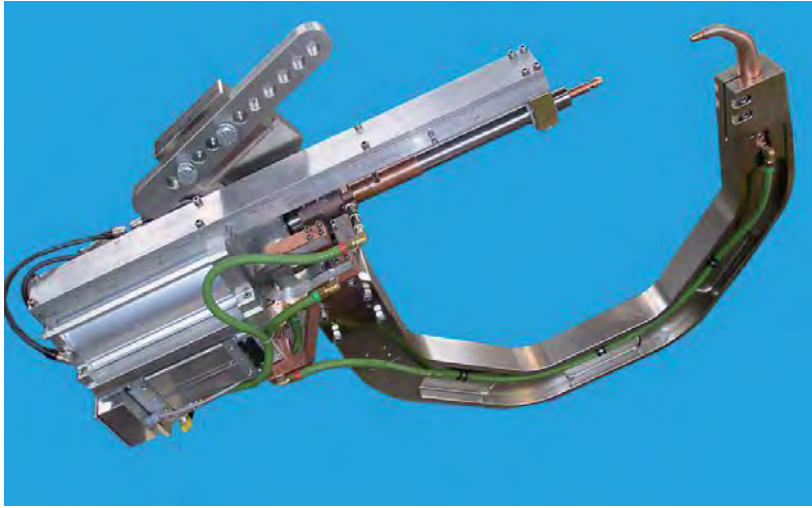

This document is exclusive property of ALESSIO (I). Reproduction or use by a third party without written consent of the company is strictly forbidden, according to EC intellectual property and copyright laws.  
Dieses Dokument ist exklusives Eigentum von ALESSIO (I). Reproduktion oder Verwendung durch Dritte ohne schriftliche Zustimmung der Firma ist strikt untersagt, gemäß den EU Gesetzen für Copyrights und geistiges Eigentum.

Ce document est la propriété exclusive de la société ALESSIO (I). La reproduction ou l'utilisation de ce document par des tiers sans une autorisation écrite de la société est interdite selon les lois CE sur la propriété intellectuelle et le copyright.  
Questo documento è proprietà esclusiva del Consorzio ALESSIO (I). Ne è pertanto vietata la riproduzione o l'utilizzo con qualsiasi mezzo senza il consenso del consorzio stesso ai sensi delle leggi CE sulla proprietà intellettuale e sul copyright.



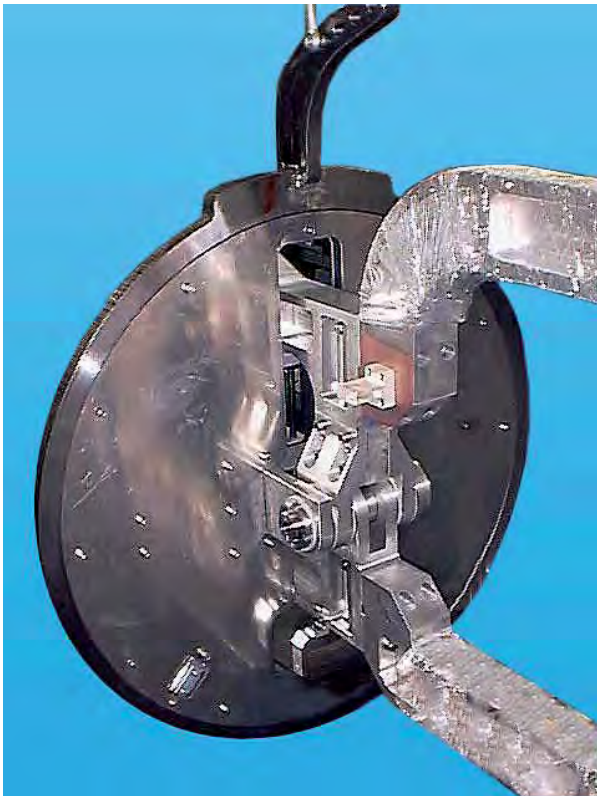

This document is exclusive property of ALESSIO (I). Reproduction or use by a third party without written consent of the company is strictly forbidden, according to EC intellectual property and copyright laws. Dieses Dokument ist exklusives Eigentum von ALESSIO (I). Reproduktion oder Verwendung durch Dritte ohne schriftliche Zustimmung der Firma ist strikt untersagt, gemäß den EU Gesetzen für Copyrights und geistiges Eigentum.

Ce document est la propriété exclusive de la société ALESSIO (I). La reproduction ou l'utilisation de ce document par des tiers sans une autorisation écrite de la société est interdite selon les lois CE sur la propriété intellectuelle et le copyright. Questo documento è proprietà esclusiva del Consorzio ALESSIO (I). Ne è pertanto vietata la riproduzione o l'utilizzo con qualsiasi mezzo senza il consenso del consorzio stesso ai sensi delle leggi CE sulla proprietà intellettuale e sul copyright.



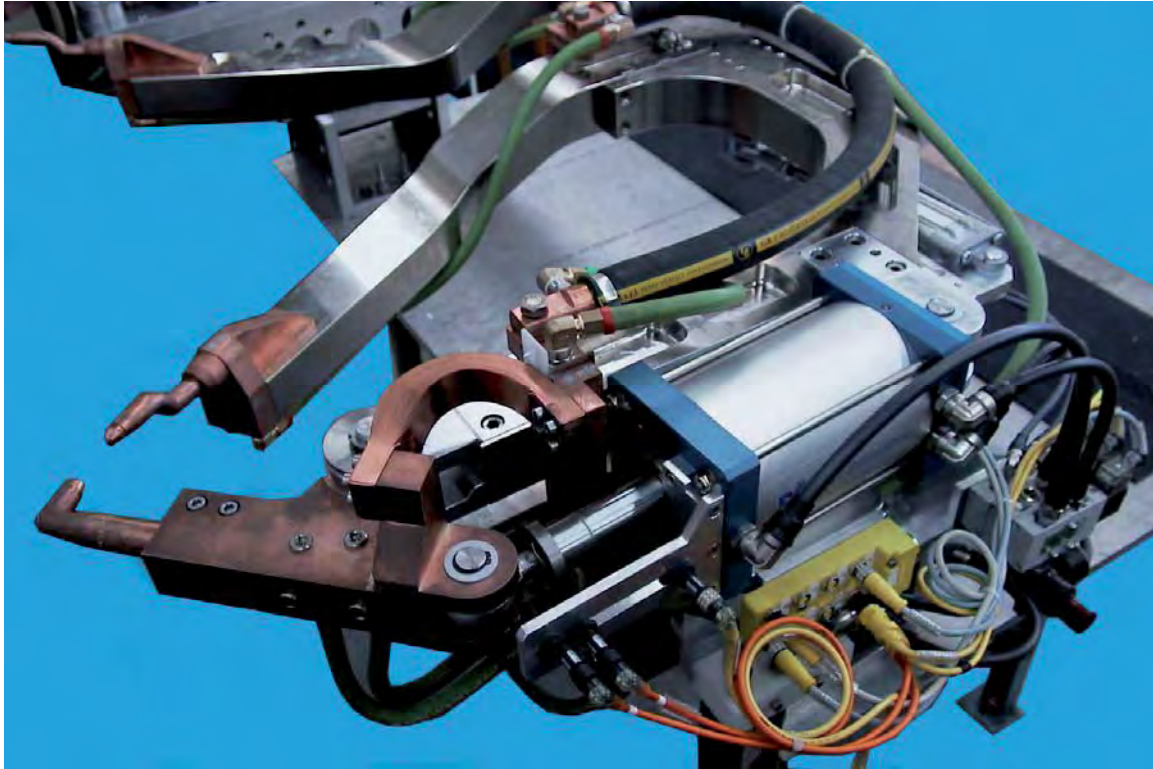
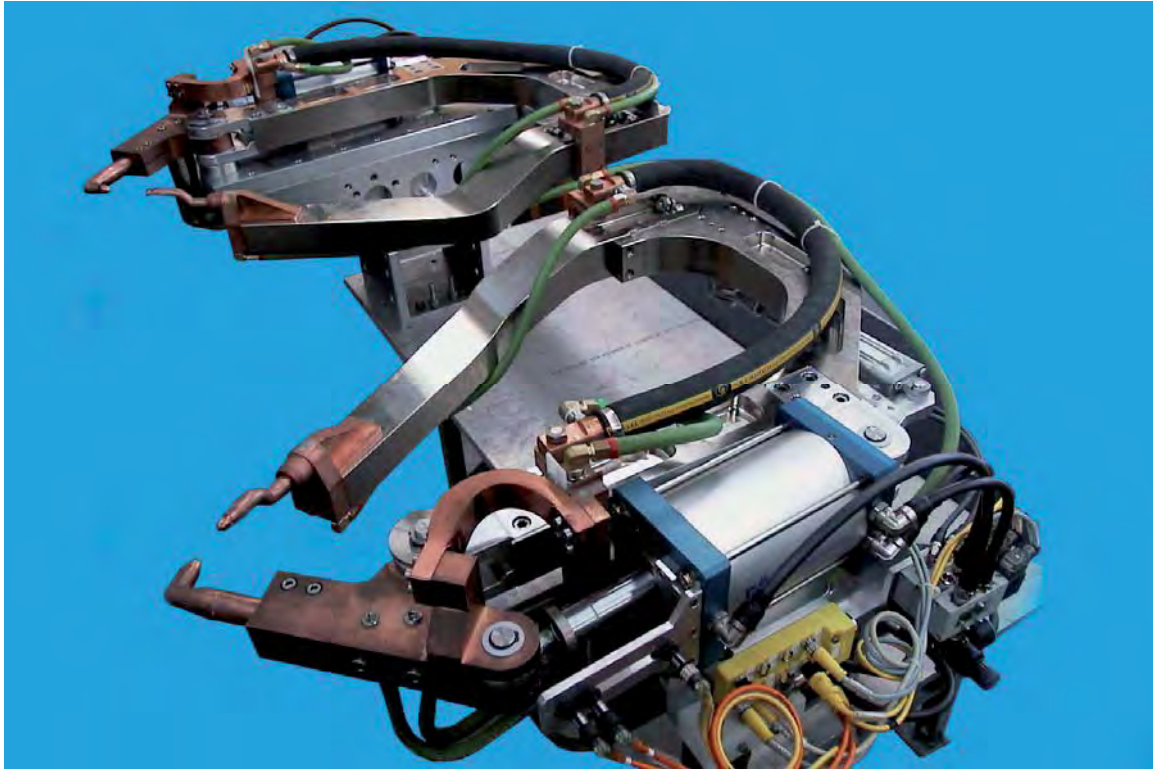

This document is exclusive property of ALESSIO (I). Reproduction or use by a third party without written consent of the company is strictly forbidden, according to EC intellectual property and copyright laws.  
Dieses Dokument ist exklusives Eigentum von ALESSIO (I). Reproduktion oder Verwendung durch Dritte ohne schriftliche Zustimmung der Firma ist strikt untersagt, gemäß den EU Gesetzen für Copyrights und geistiges Eigentum.

Ce document est la propriété exclusive de la société ALESSIO (I). La reproduction ou l'utilisation de ce document par des tiers sans une autorisation écrite de la société est interdite selon les lois CE sur la propriété intellectuelle et le copyright.  
Questo documento è proprietà esclusiva del Consorzio ALESSIO (I). Ne è pertanto vietata la riproduzione o l'utilizzo con qualsiasi mezzo senza il consenso del consorzio stesso ai sensi delle leggi CE sulla proprietà intellettuale e sul copyright.

This document is exclusive property of ALESSIO (I). Reproduction or use by a third party without written consent of the company is strictly forbidden, according to EC intellectual property and copyright laws.  
Dieses Dokument ist exklusives Eigentum von ALESSIO (I). Reproduktion oder Verwendung durch Dritte ohne schriftliche Zustimmung der Firma ist strikt untersagt, gemäß den EU Gesetzen für Copyrights und geistiges Eigentum.

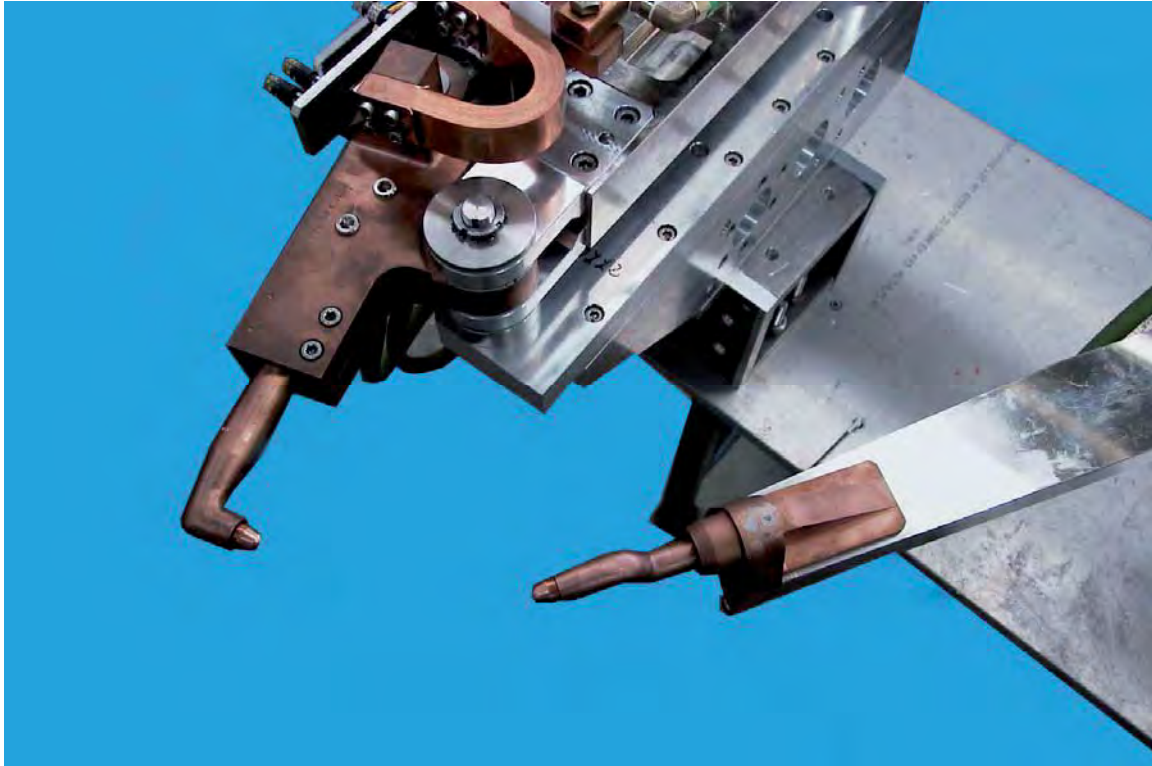
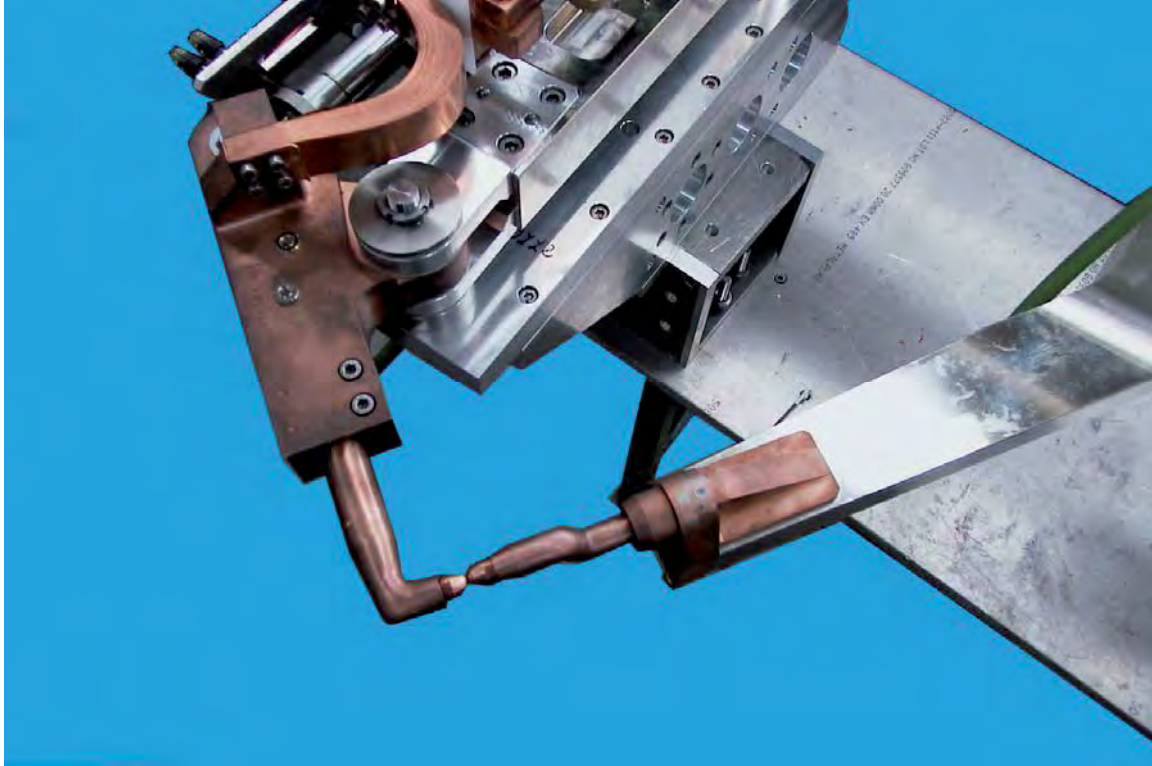

Ce document est la propriété exclusive de la société ALESSIO (I). La reproduction ou l'utilisation de ce document par des tiers sans une autorisation écrite de la société est interdite selon les lois CE sur la propriété intellectuelle et le copyright.  
Questo documento è proprietà esclusiva del Consorzio ALESSIO (I). Ne è pertanto vietata la riproduzione o l'utilizzo con qualsiasi mezzo senza il consenso del consorzio stesso ai sensi delle leggi CE sulla proprietà intellettuale e sul copyright.



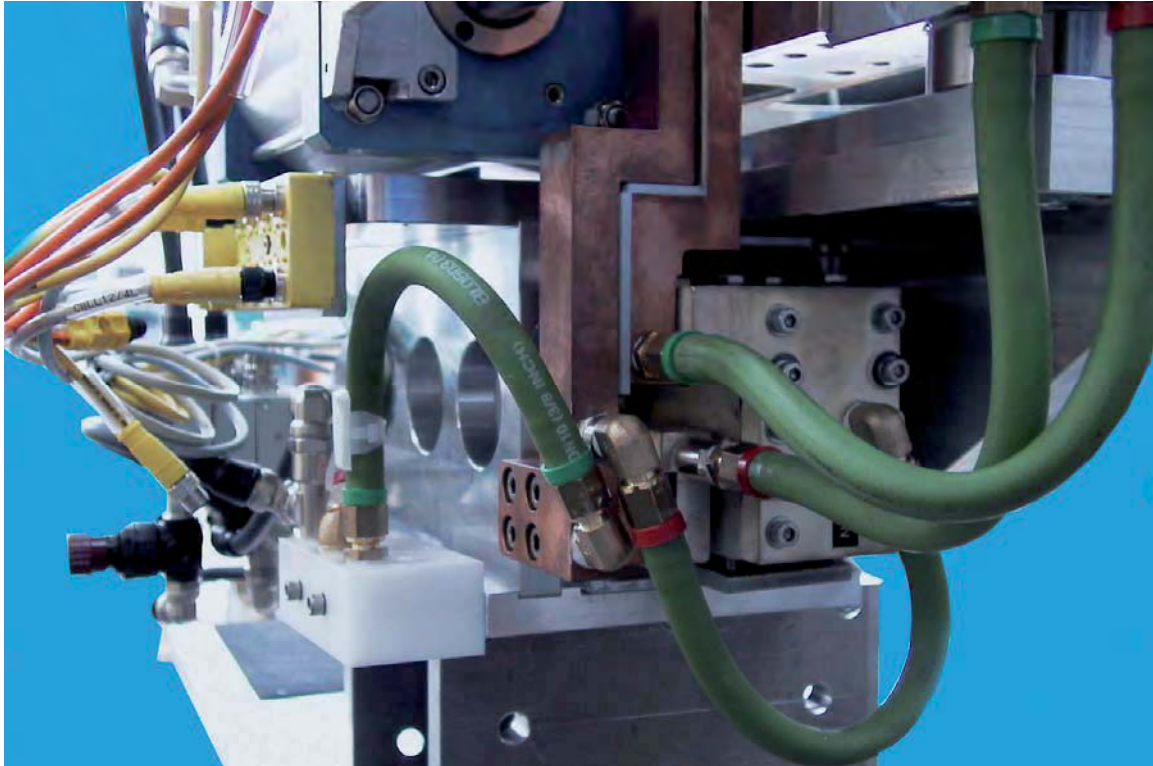
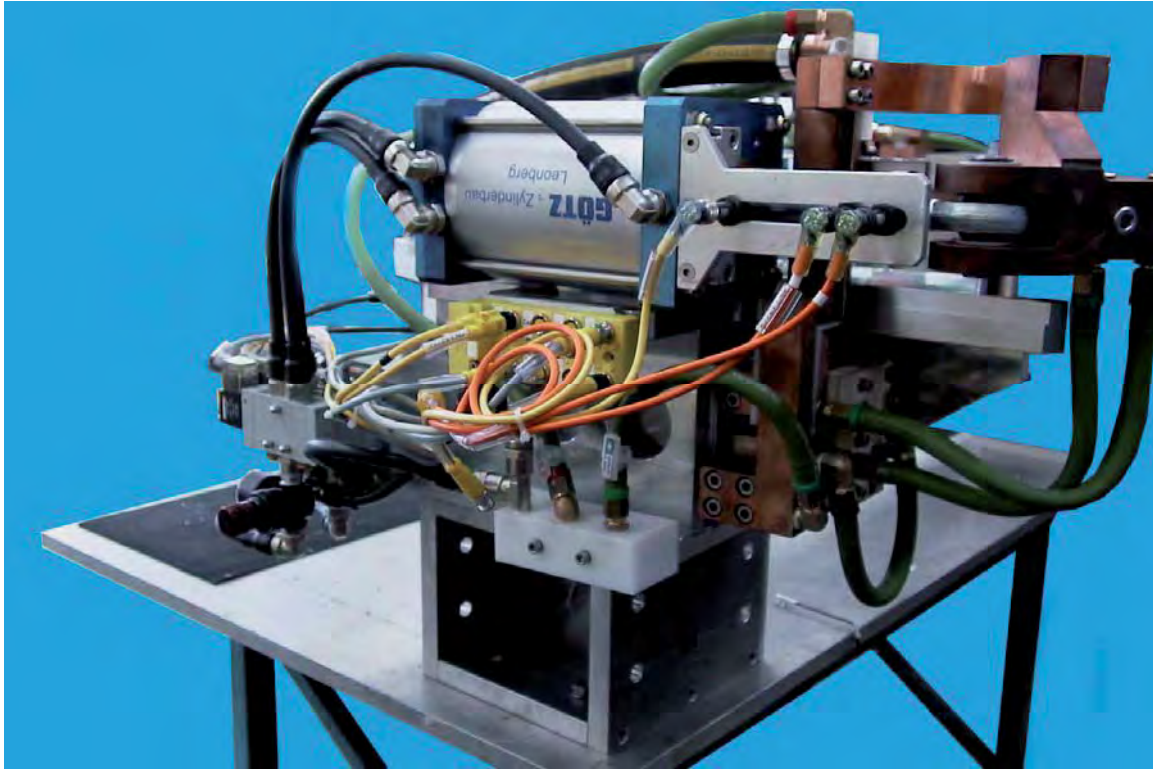

This document is exclusive property of ALESSIO (I). Reproduction or use by a third party without written consent if the company is strictly forbidden, according to EC intellectual property and copyright laws.  
Dieses Dokument ist exklusives Eigentum von ALESSIO (I). Reproduktion oder Verwendung durch Dritte ohne schriftliche Zustimmung der Firma ist strikt untersagt, gemäß den EU-Gesetzen für Copyrights und geistiges Eigentum.

Ce document est la propriété exclusive de la société ALESSIO (I). La reproduction ou l'utilisation de ce document par des tiers sans une autorisation écrite de la société est interdite selon les lois CE sur la propriété intellectuelle et le copyright.  
Questo documento è proprietà esclusiva del Consorzio ALESSIO (I). Ne è pertanto vietata la riproduzione o l'utilizzo con qualsiasi mezzo senza il consenso del consorzio stesso ai sensi delle leggi CE sulla proprietà intellettuale e sul copyright.



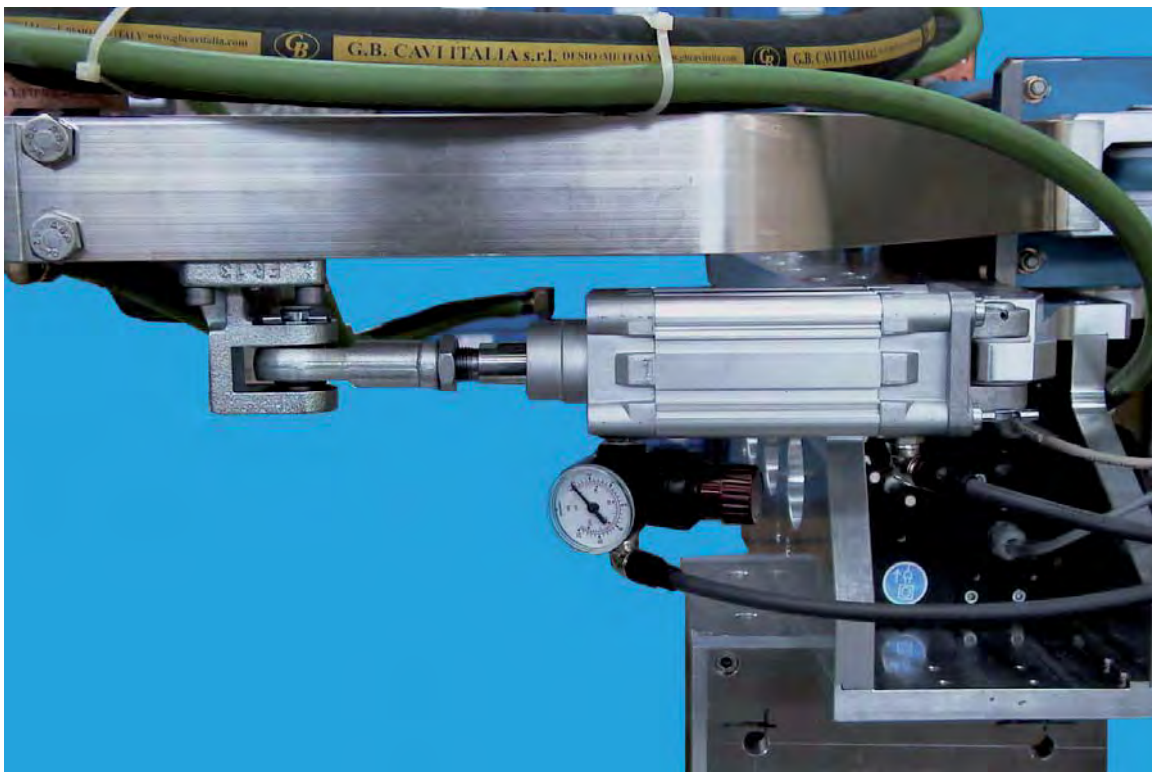
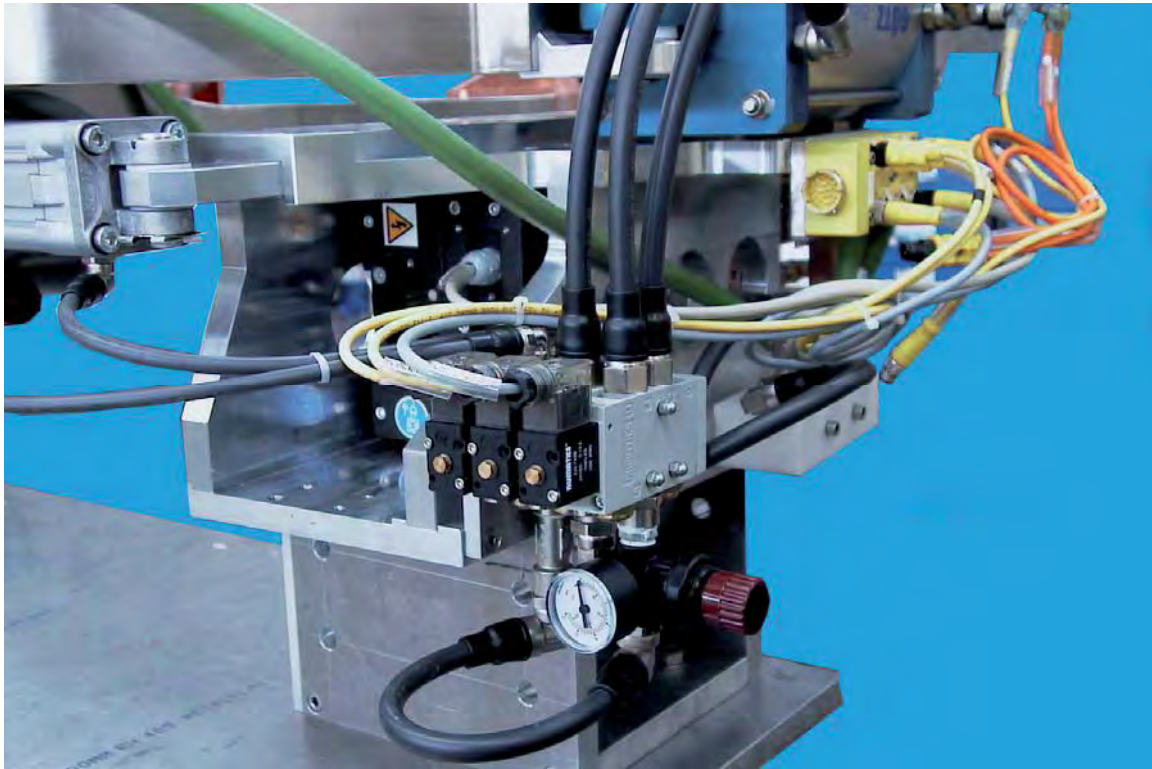

This document is exclusive property of ALESSIO (I). Reproduction or use by a third party without written consent of the company is strictly forbidden, according to EC intellectual property and copyright laws. Dieses Dokument ist exklusives Eigentum von ALESSIO (I). Reproduktion oder Verwendung durch Dritte ohne schriftliche Zustimmung der Firma ist strikt untersagt, gemäss den EU Gesetzen für Copyrights und geistiges Eigentum.

Ce document est la propriété exclusive de la société ALESSIO (I). La reproduction ou l'utilisation de ce document par des tiers sans une autorisation écrite de la société est interdite selon les lois CE sur la propriété intellectuelle et le copyright. Questo documento è proprietà esclusiva del Consorzio ALESSIO (I). Ne è pertanto vietata la riproduzione o l'utilizzo con qualsiasi mezzo senza il consenso del consorzio stesso ai sensi delle leggi CE sulla proprietà intellettuale e sul copyright.

Some examples of large guns with standard body in Aluminium alloy. Secondary areas can easily reach 100 dm<sup>3</sup> and very often MF transformers are used to avoid the high current losses existing with traditional ISO transformers. Pressure and flow regulators adjust arm speed.



This document is exclusive property of ALESSIO (I). Reproduction or use by a third party without written consent of the company is strictly forbidden, according to EC intellectual property and copyright laws. Dieses Dokument ist exklusives Eigentum von ALESSIO (I). Reproduktion oder Verwendung durch Dritte ohne schriftliche Zustimmung der Firma ist strikt untersagt, gemäß den EU-Gesetzen für Copyrights und geistiges Eigentum.

Ce document est la propriété exclusive de la société ALESSIO (I). La reproduction ou l'utilisation de ce document par des tiers sans une autorisation écrite de la société est interdite selon les lois CE sur la propriété intellectuelle et le copyright. Questo documento è proprietà esclusiva del Consorzio ALESSIO (I). Ne è pertanto vietata la riproduzione o l'utilizzo con qualsiasi mezzo senza il consenso del consorzio stesso ai sensi delle leggi CE sulla proprietà intellettuale e sul copyright.



This document is exclusive property of ALESSIO (I). Reproduction or use by a third party without written consent of the company is strictly forbidden, according to EC intellectual property and copyright laws. Dieses Dokument ist exklusives Eigentum von ALESSIO (I). Reproduktion oder Verwendung durch Dritte ohne schriftliche Zustimmung der Firma ist strikt untersagt, gemäß den EU Gesetzen für Copyrights und geistiges Eigentum.

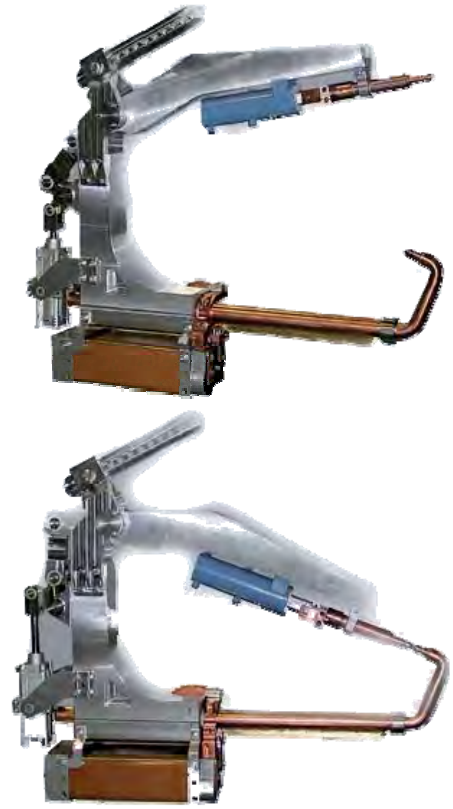

Ce document est la propriété exclusive de la société ALESSIO (I). La reproduction ou l'utilisation de ce document par des tiers sans une autorisation écrite de la société est interdite selon les lois CE sur la propriété intellectuelle et le copyright. Questo documento è proprietà esclusiva del Consorzio ALESSIO (I). Ne è pertanto vietata la riproduzione o l'utilizzo con qualsiasi mezzo senza il consenso del consorzio stesso ai sensi delle leggi CE sulla proprietà intellettuale e sul copyright.



This document is exclusive property of ALESSIO (I). Reproduction or use by a third party without written consent of the company is strictly forbidden, according to EC intellectual property and copyright laws. Dieses Dokument ist exklusives Eigentum von ALESSIO (I). Reproduktion oder Verwendung durch Dritte ohne schriftliche Zustimmung der Firma ist strikt untersagt, gemäß den EU Gesetzen für Copyrights und geistiges Eigentum.

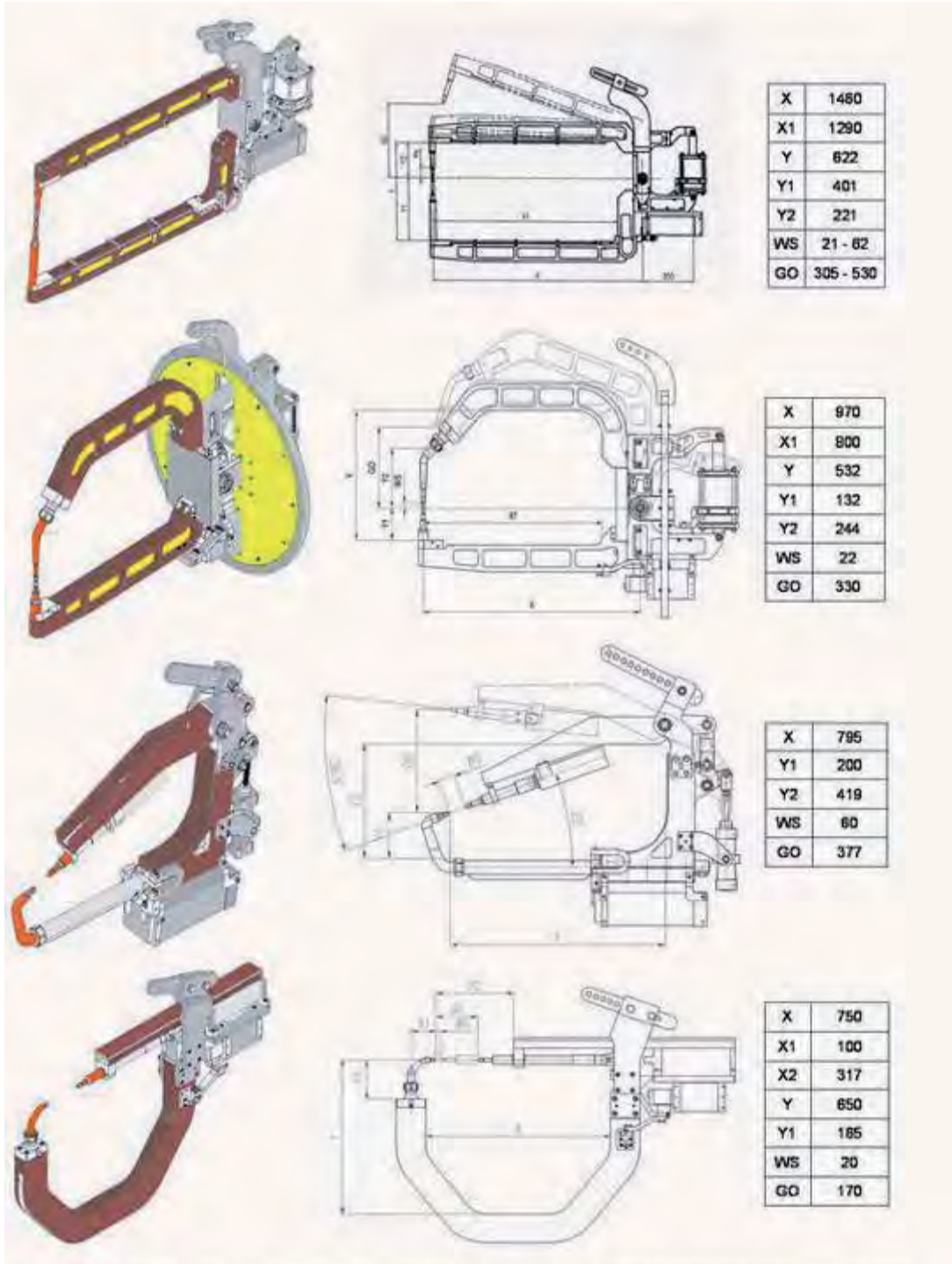

Ce document est la propriété exclusive de la société ALESSIO (I). La reproduction ou l'utilisation de ce document par des tiers sans une autorisation écrite de la société est interdite selon les lois CE sur la propriété intellectuelle et le copyright. Questo documento è proprietà esclusiva del Consorzio ALESSIO (I). Ne è pertanto vietata la riproduzione o l'utilizzo con qualsiasi mezzo senza il consenso del consorzio stesso ai sensi delle leggi CE sulla proprietà intellettuale e sul copyright.

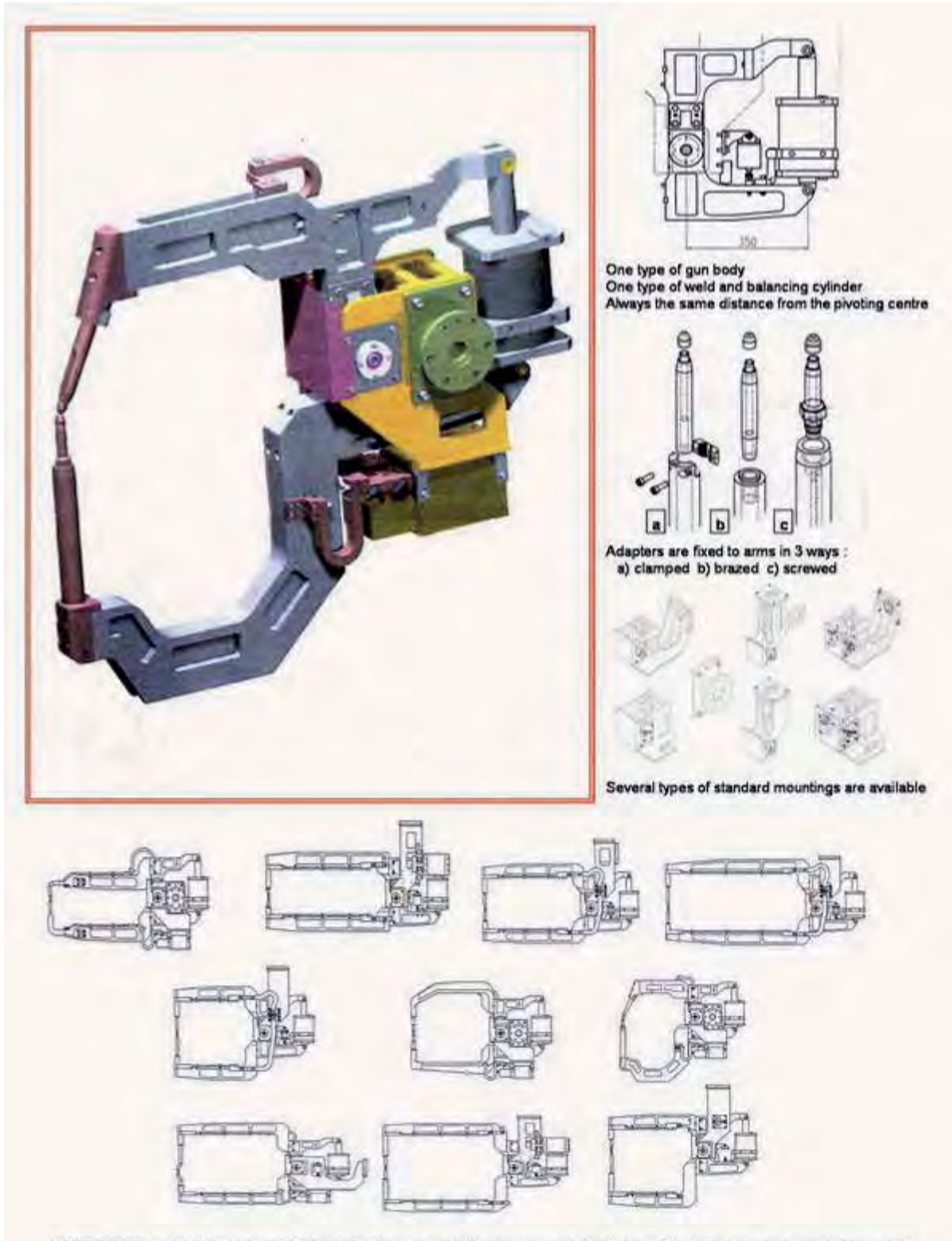

One type of gun body  
 One type of weld and balancing cylinder  
 Always the same distance from the pivoting centre

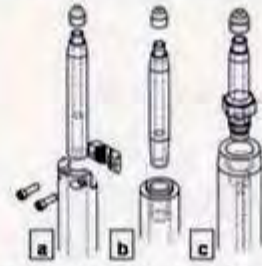

Adapters are fixed to arms in 3 ways :  
 a) clamped b) brazed c) screwed



Several types of standard mountings are available

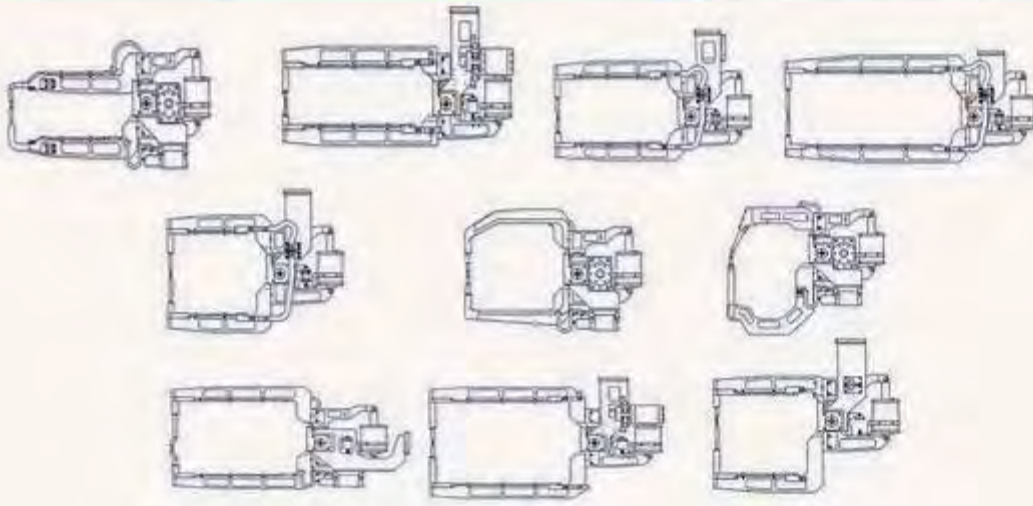

This document is exclusive property of ALESSIO (I). Reproduction or use by a third party without written consent of the company is strictly forbidden, according to EC intellectual property and copyright laws.  
 Dieses Dokument ist exklusives Eigentum von ALESSIO (I). Reproduktion oder Verwendung durch Dritte ohne schriftliche Zustimmung der Firma ist strikt untersagt, gemäß den EU Gesetzen für Copyrights und geistiges Eigentum.

Ce document est la propriété exclusive de la société ALESSIO (I). La reproduction ou l'utilisation de ce document par des tiers sans une autorisation écrite de la société est interdite selon les lois CE sur la propriété intellectuelle et le copyright.  
 Questo documento è proprietà esclusiva del Consorzio ALESSIO (I). Ne è pertanto vietata la riproduzione o l'utilizzo con qualsiasi mezzo senza il consenso del consorzio stesso ai sensi delle leggi CE sulla proprietà intellettuale e sul copyright.



## Large Scissor Robot-Gun "LSRG" type

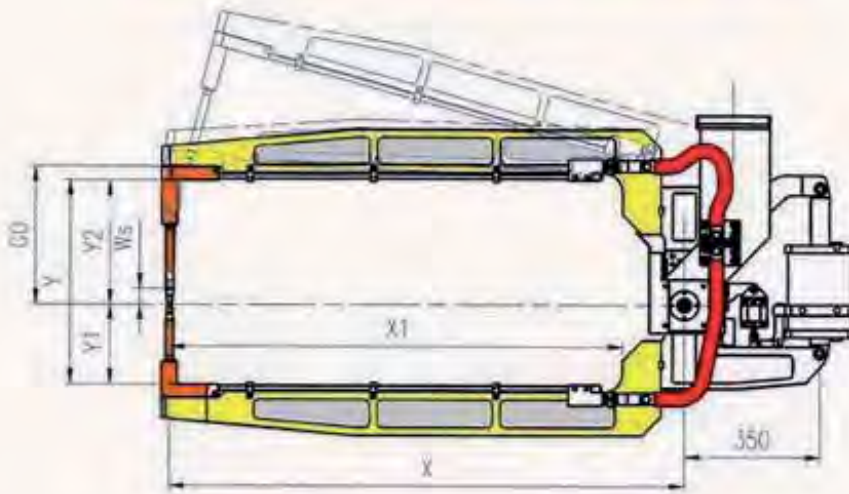

Dwg No.	X [mm]	X1 [mm]	Y [mm]	Y1 [mm]	Y2 [mm]	A=X1*Y [dm <sup>2</sup> ]	F at 1bar [daN]
PWA26911	630	450	625	400	225	28	105
PWA26327	750	590	553	277	276	33	88
PWA26327/1	750	590	553	367	186	32	88
PWA26903	750	590	610	255	355	36	88
PWA26902	915	755	375	115	260	19	68
PWA26782	960	800	462	186	276	43	68
PWA26355	960	800	553	277	276	44	69
PWA26900	980	820	644	227	417	52	63
PWA27679	1060	900	720	360	360	64	64
PWA27680	1090	930	338	124	214	30	64
PWA26326/1	1340	1180	517	201	316	61	50

Dwg No.	X [mm]	WS [mm]			GO [mm]									
		WS-4	WS-7	WS-10	GO-4	GO-7	GO-10	GO-13	GO-16	GO-19	GO-22	GO-25	GO-28	
PWA26911	630	27	14	9	229	218	213	189	177	172	148	136	131	
PWA26327	750	32	17	11	273	259	253	225	211	205	176	162	156	
PWA26327/1	750	32	17	11	273	259	253	225	211	205	176	162	156	
PWA26903	750	32	17	11	273	259	253	225	211	205	176	162	156	
PWA26902	915	39	21	13	333	316	309	275	258	250	215	197	190	
PWA26782	960	41	22	14	349	332	324	289	270	263	226	207	199	
PWA26355	960	41	22	14	349	332	324	289	270	263	226	207	199	
PWA26900	980	42	22	14	357	339	331	295	276	268	230	211	203	
PWA27679	1060	45	24	15	386	366	358	319	299	290	249	229	220	
PWA27680	1090	46	25	16	397	377	368	328	307	298	256	235	226	
PWA26326/1	1340	57	31	19	488	463	452	403	377	366	315	289	278	

This document is exclusive property of ALESSIO (I). Reproduction or use by a third party without written consent of the company is strictly forbidden, according to EC intellectual property and copyright laws. Dieses Dokument ist exklusives Eigentum von ALESSIO (I). Reproduktion oder Verwendung durch Dritte ohne schriftliche Zustimmung der Firma ist strikt untersagt, gemäß den EU Gesetzen für Copyrights und geistiges Eigentum.

Ce document est la propriété exclusive de la société ALESSIO (I). La reproduction ou l'utilisation de ce document par des tiers sans une autorisation écrite de la société est interdite selon les lois CE sur la propriété intellectuelle et le copyright. Questo documento è proprietà esclusiva del Consorzio ALESSIO (I). Ne è pertanto vietata la riproduzione o l'utilizzo con qualsiasi mezzo senza il consenso del consorzio stesso ai sensi delle leggi CE sulla proprietà intellettuale e sul copyright.



## Large Scissor Robot-Gun "LSRG" type

- The gun body is standard and common to all types, made in high-resistance Al alloy
- There is one type of cylinder only
- Different spacers put inside the cylinder allow various high-lifts and weld-strokes
- All guns can be fitted with ISO or MF transformers

High-lift with 0-25-50mm thick spacers in long stroke chamber and with 0-7-10mm thick ones in the short-stroke chamber

GO (High-lift) vs. work throat depth with a 0 mm thick spacer in the long-stroke chamber and with a 0-7-10mm thick spacer in short stroke

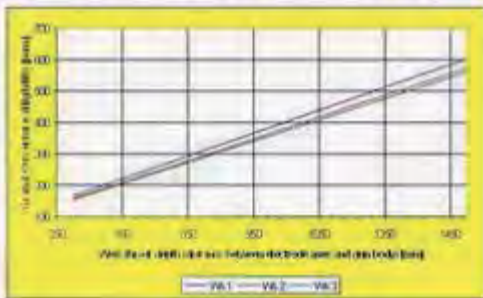

GO (High-lift) vs. work throat depth with a 25 mm thick spacer in the long-stroke chamber and with a 0-7-10mm thick spacer in short stroke

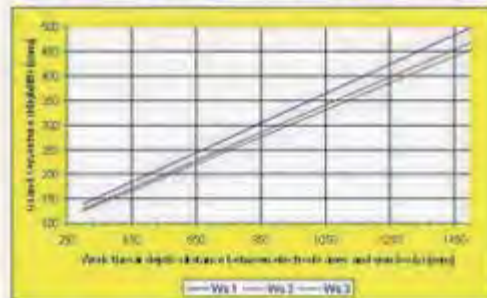

GO (High-lift) vs. work throat depth with a 50 mm thick spacer in the long-stroke chamber and with a 0-7-10mm thick spacer in short stroke

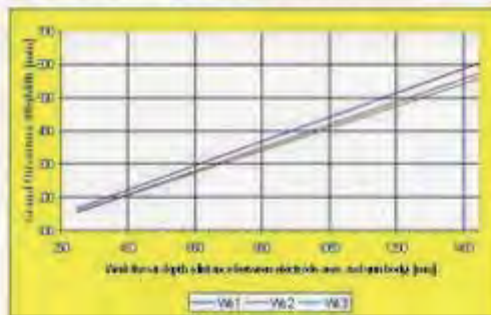

## Work-stroke with a 0-7-10 mm thick spacer in short stroke chamber of cylinder

Work-stroke vs. work throat depth with a 0 mm thick spacer in the long-stroke chamber and with a 0-7-10mm thick spacer in cylinder short stroke

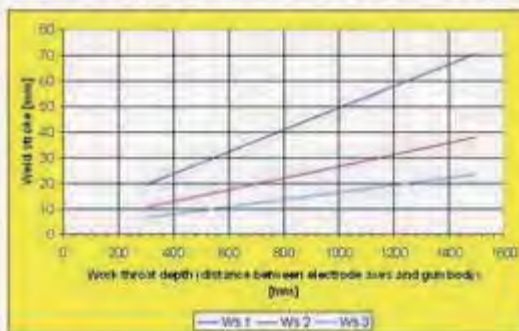

GO (High-lift) vs. work throat depth with a 0 mm thick spacer in the long-stroke chamber and with a 0-7-10mm thick spacer in cylinder short stroke

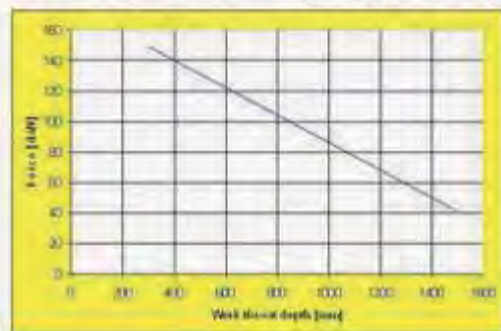

# PEDESTAL

# GUNS

This document is exclusive property of ALESSIO (I). Reproduction or use by a third party without written consent of the company is strictly forbidden, according to EC intellectual property and copyright laws.  
Dieses Dokument ist exklusives Eigentum von ALESSIO (I). Reproduktion oder Verwendung durch Dritte ohne schriftliche Zustimmung der Firma ist strikt untersagt, gemäß den EU Gesetzen für Copyrights und geistiges Eigentum.

Ce document est la propriété exclusive de la société ALESSIO (I). La reproduction ou l'utilisation de ce document par des tiers sans une autorisation écrite de la société est interdite selon les lois CE sur la propriété intellectuelle et le copyright.  
Questo documento è proprietà esclusiva del Consorzio ALESSIO (I). Ne è pertanto vietata la riproduzione o l'utilizzo con qualsiasi mezzo senza il consenso del consorzio stesso ai sensi delle leggi CE sulla proprietà intellettuale e sul copyright.

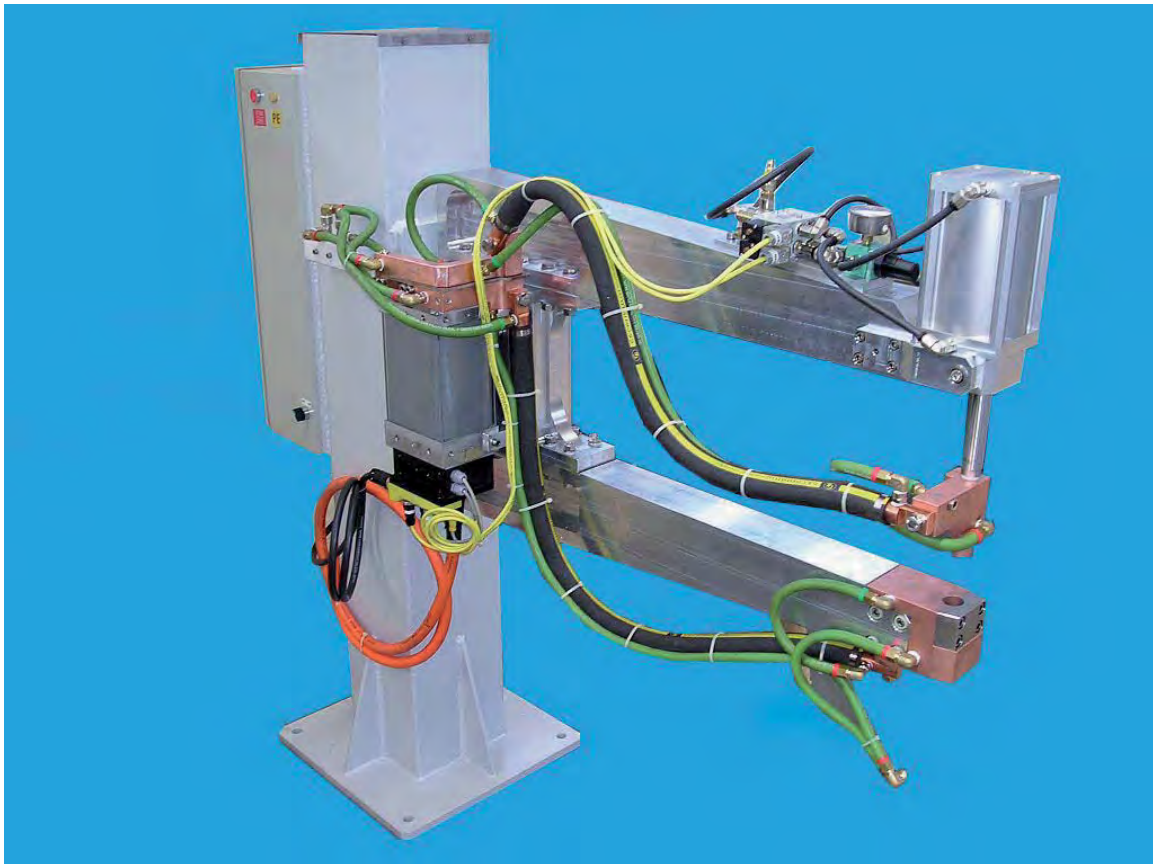
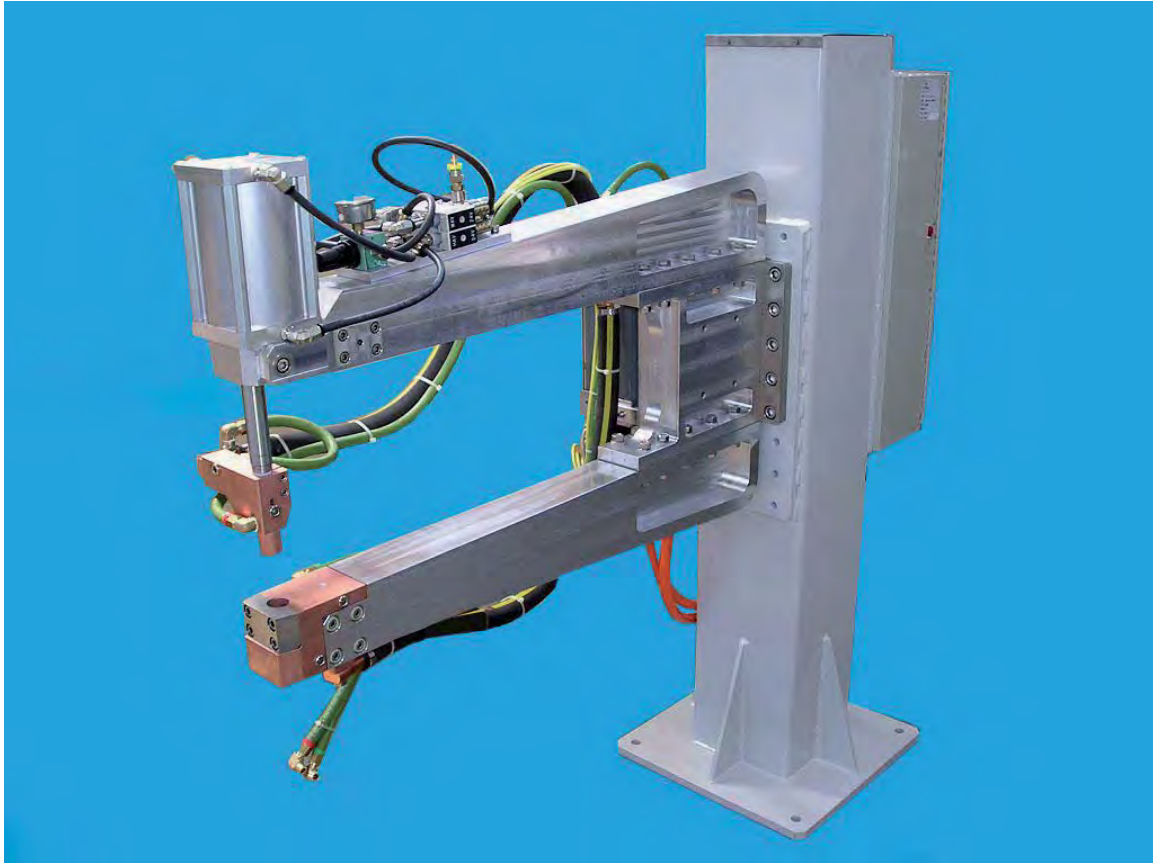

This document is exclusive property of ALESSIO (I). Reproduction or use by a third party without written consent of the company is strictly forbidden, according to EC intellectual property and copyright laws.  
Dieses Dokument ist exklusives Eigentum von ALESSIO (I). Reproduktion oder Verwendung durch Dritte ohne schriftliche Zustimmung der Firma ist strikt untersagt, gemäß den EU Gesetzen für Copyrights und geistiges Eigentum.

Ce document est la propriété exclusive de la société ALESSIO (I). La reproduction ou l'utilisation de ce document par des tiers sans une autorisation écrite de la société est interdite selon les lois CE sur la propriété intellectuelle et le copyright.  
Questo documento è proprietà esclusiva del Consorzio ALESSIO (I). Ne è pertanto vietata la riproduzione o l'utilizzo con qualsiasi mezzo senza il consenso del consorzio stesso ai sensi delle leggi CE sulla proprietà intellettuale e sul copyright.



# Our Large Guns

## exhibited at

# ESSEN

## Welding Show

### (Sept. 2005)

This document is exclusive property of ALESSIO (I). Reproduction or use by a third party without written consent of the company is strictly forbidden, according to EC intellectual property and copyright laws.  
Dieses Dokument ist exklusives Eigentum von ALESSIO (I). Reproduktion oder Verwendung durch Dritte ohne schriftliche Zustimmung der Firma ist strikt untersagt, gemäß den EU Gesetzen für Copyrights und geistiges Eigentum.

Ce document est la propriété exclusive de la société ALESSIO (I). La reproduction ou l'utilisation de ce document par des tiers sans une autorisation écrite de la société est interdite selon les lois CE sur la propriété intellectuelle et le copyright.  
Questo documento è proprietà esclusiva del Consorzio ALESSIO (I). Ne è pertanto vietata la riproduzione o l'utilizzo con qualsiasi mezzo senza il consenso del consorzio stesso ai sensi delle leggi CE sulla proprietà intellettuale e sul copyright.

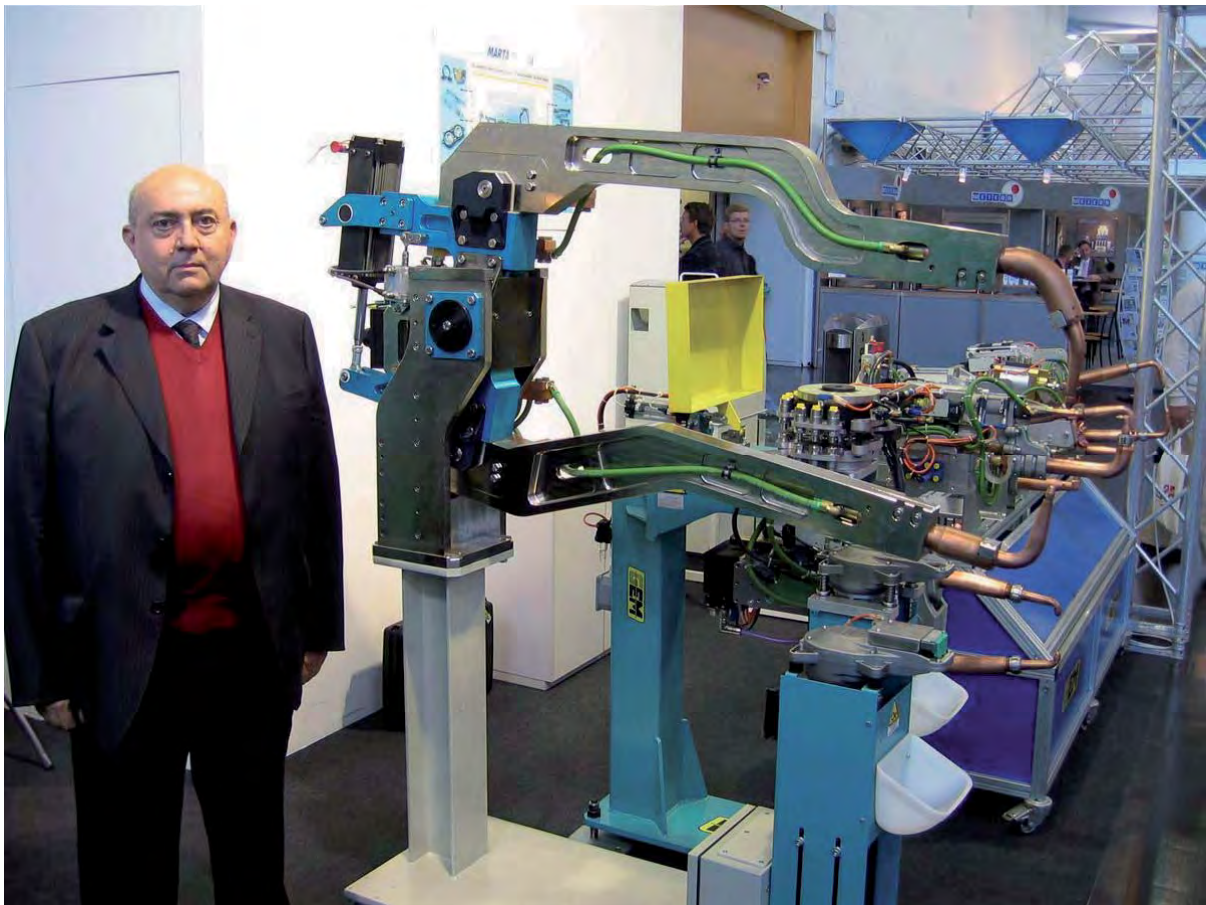
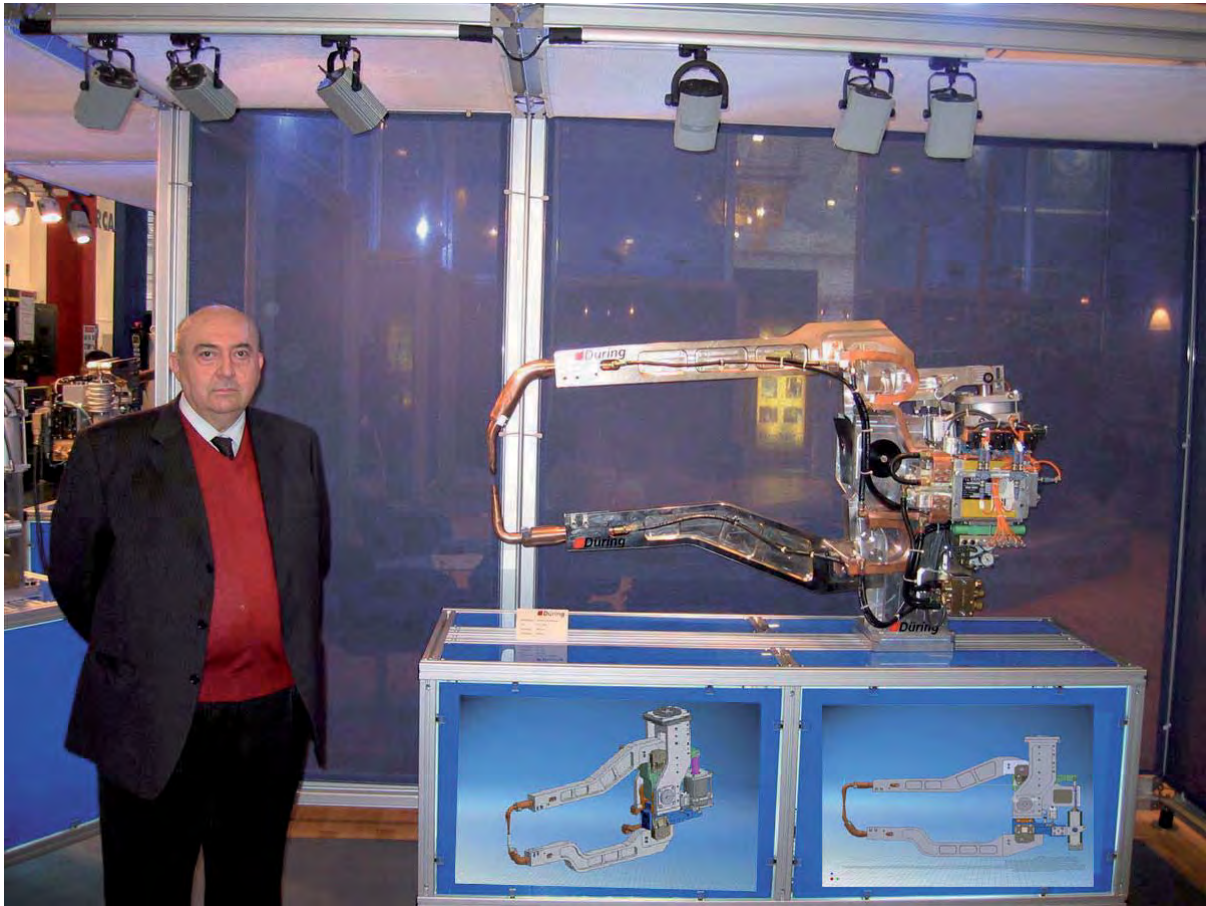

This document is exclusive property of ALESSIO (I). Reproduction or use by a third party without written consent of the company is strictly forbidden, according to EC intellectual property and copyright laws.  
Dieses Dokument ist exklusives Eigentum von ALESSIO (I). Reproduktion oder Verwendung durch Dritte ohne schriftliche Zustimmung der Firma ist strikt untersagt, gemäß den EU Gesetzen für Copyrights und geistiges Eigentum.

Ce document est la propriété exclusive de la société ALESSIO (I). La reproduction ou l'utilisation de ce document par des tiers sans une autorisation écrite de la société est interdite selon les lois CE sur la propriété intellectuelle et le copyright.  
Questo documento è proprietà esclusiva del Consorzio ALESSIO (I). Ne è pertanto vietata la riproduzione o l'utilizzo con qualsiasi mezzo senza il consenso del consorzio stesso ai sensi delle leggi CE sulla proprietà intellettuale e sul copyright.



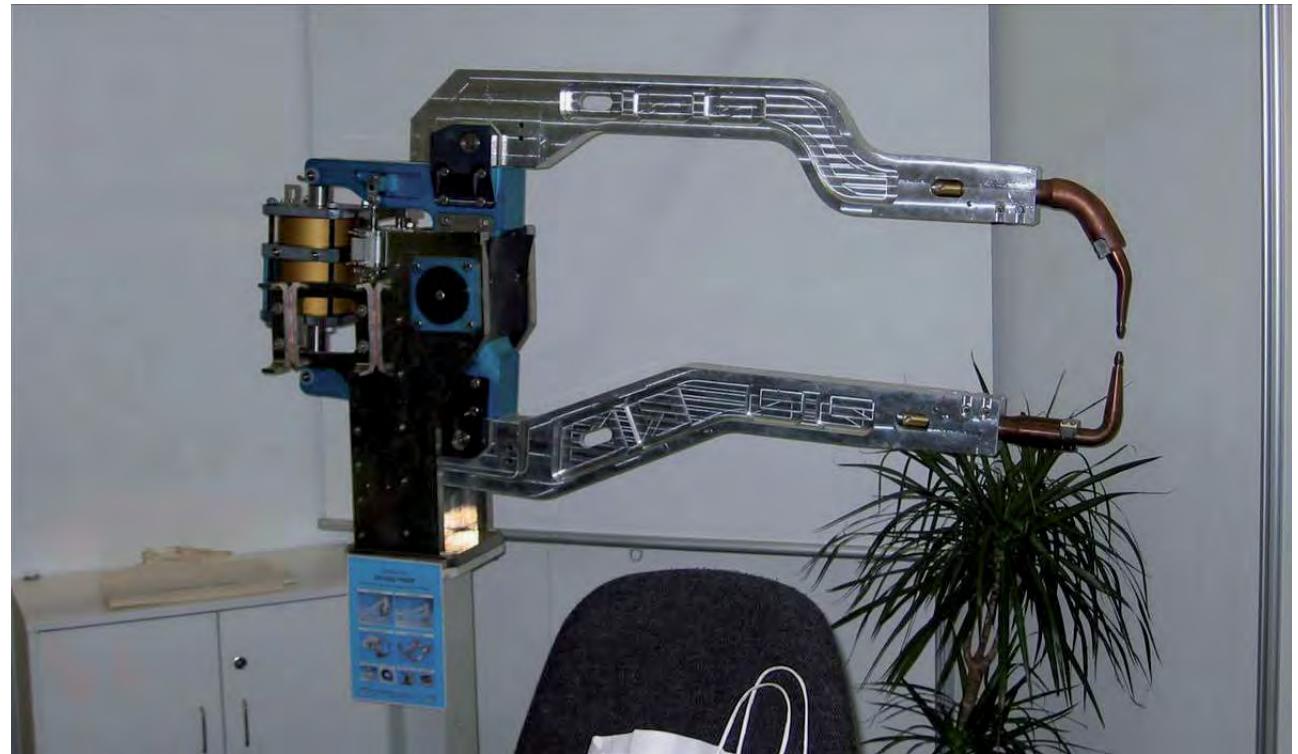

This document is exclusive property of ALESSIO (I). Reproduction or use by a third party without written consent of the company is strictly forbidden, according to EC intellectual property and copyright laws.  
Dieses Dokument ist exklusives Eigentum von ALESSIO (I). Reproduktion oder Verwendung durch Dritte ohne schriftliche Zustimmung der Firma ist strikt untersagt, gemäß den EU Gesetzen für Copyrights und geistiges Eigentum.

Ce document est la propriété exclusive de la société ALESSIO (I). La reproduction ou l'utilisation de ce document par des tiers sans une autorisation écrite de la société est interdite selon les lois CE sur la propriété intellectuelle et le copyright.  
Questo documento è proprietà esclusiva del Consorzio ALESSIO (I). Ne è pertanto vietata la riproduzione o l'utilizzo con qualsiasi mezzo senza il consenso del consorzio stesso ai sensi delle leggi CE sulla proprietà intellettuale e sul copyright.



# Large Guns at Work on ROBOTS

This document is exclusive property of ALESSIO (I). Reproduction or use by a third party without written consent of the company is strictly forbidden, according to EC intellectual property and copyright laws.  
Dieses Dokument ist exklusives Eigentum von ALESSIO (I). Reproduktion oder Verwendung durch Dritte ohne schriftliche Zustimmung der Firma ist strikt untersagt, gemäß den EU Gesetzen für Copyrights und geistiges Eigentum.

Ce document est la propriété exclusive de la société ALESSIO (I). La reproduction ou l'utilisation de ce document par des tiers sans une autorisation écrite de la société est interdite selon les lois CE sur la propriété intellectuelle et le copyright.  
Questo documento è proprietà esclusiva del Consorzio ALESSIO (I). Ne è pertanto vietata la riproduzione o l'utilizzo con qualsiasi mezzo senza il consenso del consorzio stesso ai sensi delle leggi CE sulla proprietà intellettuale e sul copyright.

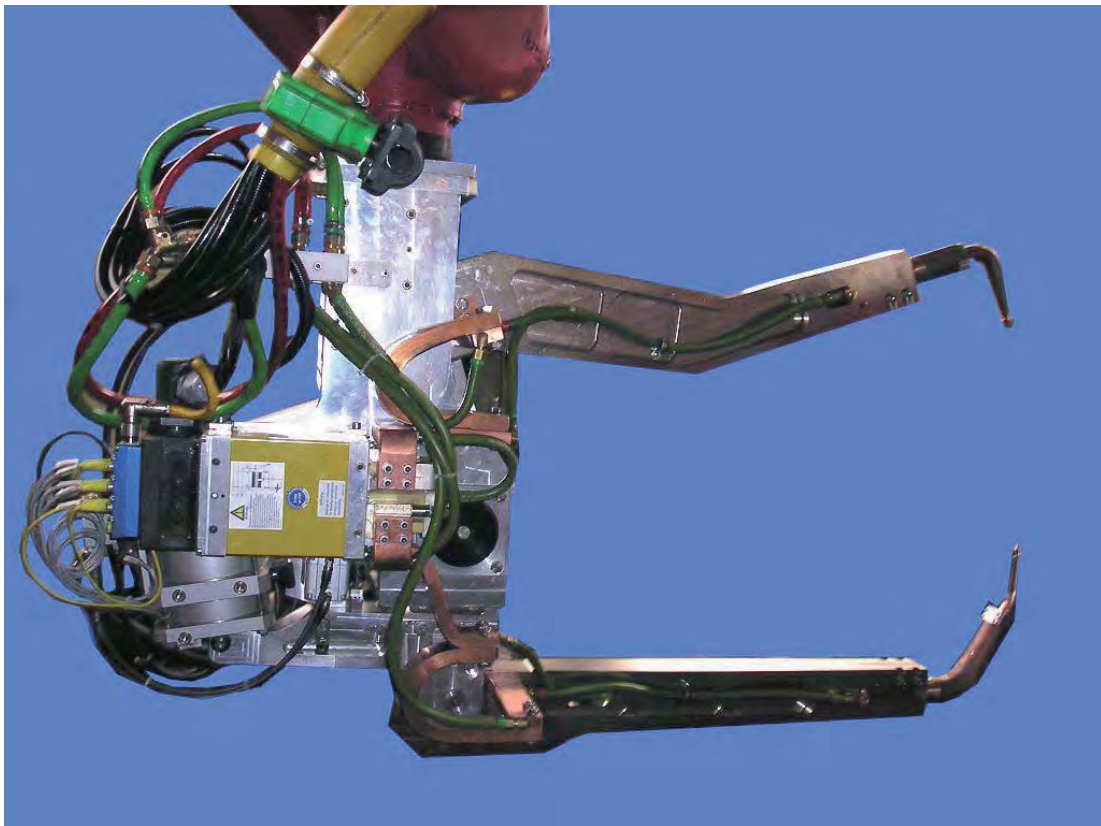
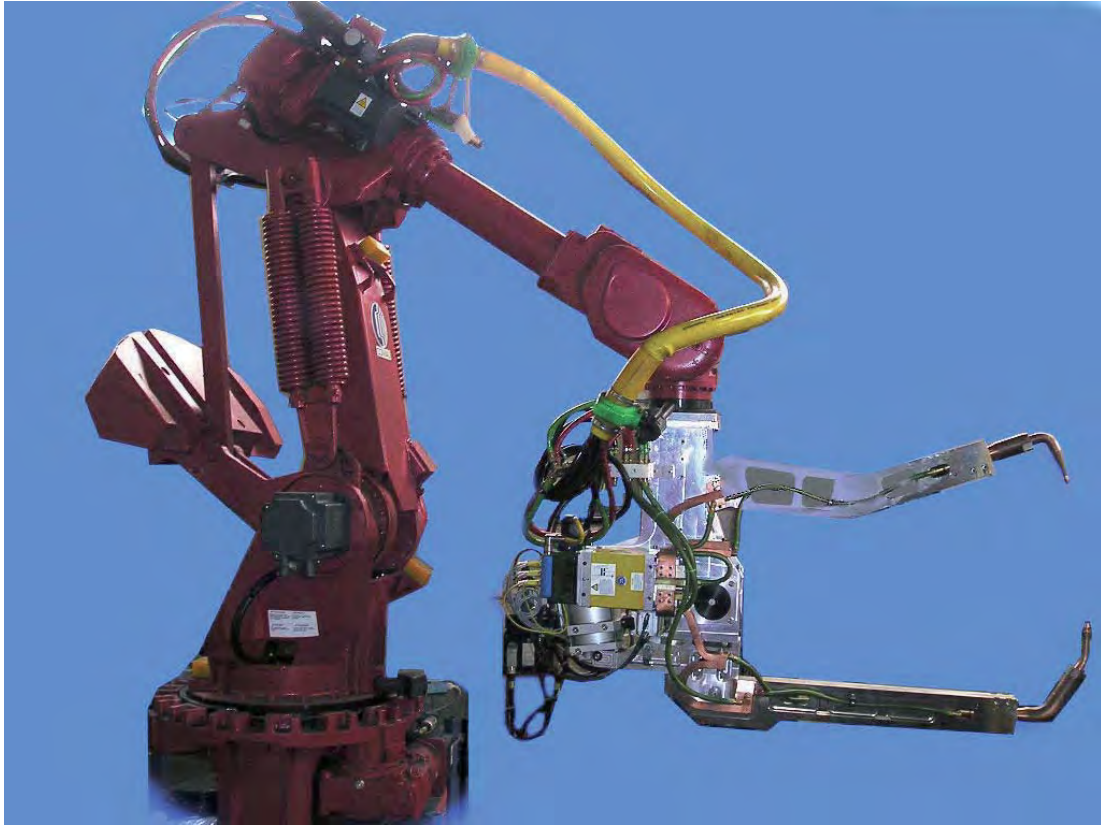

This document is exclusive property of ALESSIO (I). Reproduction or use by a third party without written consent of the company is strictly forbidden, according to EC intellectual property and copyright laws.  
Dieses Dokument ist exklusives Eigentum von ALESSIO (I). Reproduktion oder Verwendung durch Dritte ohne schriftliche Zustimmung der Firma ist strikt untersagt, gemäß den EU-Gesetzen für Copyrights und geistiges Eigentum.

Ce document est la propriété exclusive de la société ALESSIO (I). La reproduction ou l'utilisation de ce document par des tiers sans une autorisation écrite de la société est interdite selon les lois CE sur la propriété intellectuelle et le copyright.  
Questo documento è proprietà esclusiva del Consorzio ALESSIO (I). Ne è pertanto vietata la riproduzione o l'utilizzo con qualsiasi mezzo senza il consenso del consorzio stesso ai sensi delle leggi CE sulla proprietà intellettuale e sul copyright.

This document is exclusive property of ALESSIO (I). Reproduction or use by a third party without written consent of the company is strictly forbidden, according to EC intellectual property and copyright laws.  
Dieses Dokument ist exklusives Eigentum von ALESSIO (I). Reproduktion oder Verwendung durch Dritte ohne schriftliche Zustimmung der Firma ist strikt untersagt, gemäß den EU Gesetzen für Copyrights und geistiges Eigentum.

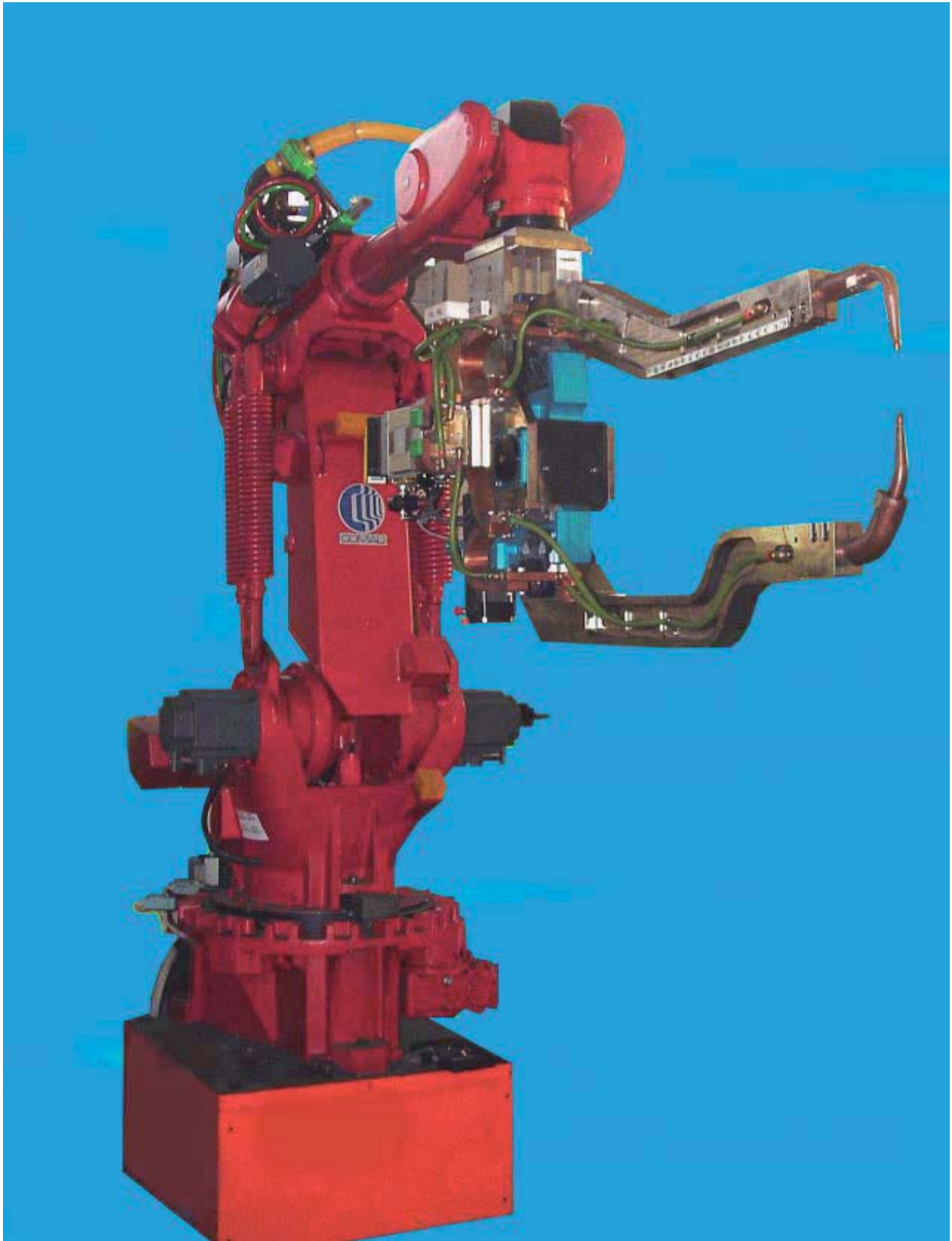

Ce document est la propriété exclusive de la société ALESSIO (I). La reproduction ou l'utilisation de ce document par des tiers sans une autorisation écrite de la société est interdite selon les lois CE sur la propriété intellectuelle et le copyright.  
Questo documento è proprietà esclusiva del Consorzio ALESSIO (I). Ne è pertanto vietata la riproduzione o l'utilizzo con qualsiasi mezzo senza il consenso del consorzio stesso ai sensi delle leggi CE sulla proprietà intellettuale e sul copyright.



This document is exclusive property of ALESSIO (I). Reproduction or use by a third party without written consent of the company is strictly forbidden, according to EC intellectual property and copyright laws.  
Dieses Dokument ist exklusives Eigentum von ALESSIO (I). Reproduktion oder Verwendung durch Dritte ohne schriftliche Zustimmung der Firma ist strikt untersagt, gemäss den EU Gesetzen für Copyrights und geistiges Eigentum.

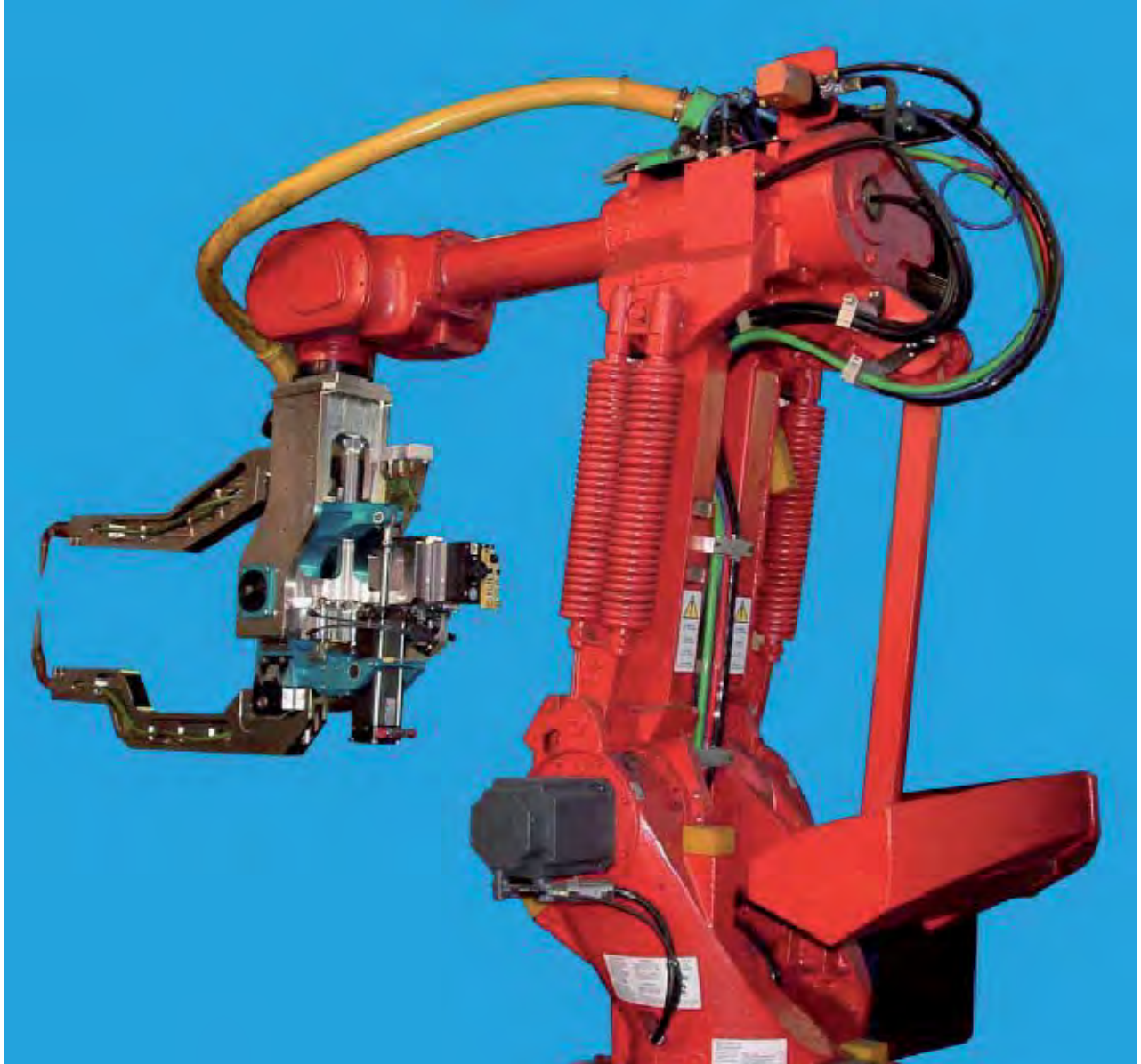

Ce document est la propriété exclusive de la société ALESSIO (I). La reproduction ou l'utilisation de ce document par des tiers sans une autorisation écrite de la société est interdite selon les lois CE sur la propriété intellectuelle et le copyright.  
Questo documento è proprietà esclusiva del Consorzio ALESSIO (I). Ne è pertanto vietata la riproduzione o l'utilizzo con qualsiasi mezzo senza il consenso del consorzio stesso ai sensi delle leggi CE sulla proprietà intellettuale e sul copyright.

This document is exclusive property of ALESSIO (I). Reproduction or use by a third party without written consent of the company is strictly forbidden, according to EC intellectual property and copyright laws.  
Dieses Dokument ist exklusives Eigentum von ALESSIO (I). Reproduktion oder Verwendung durch Dritte ohne schriftliche Zustimmung der Firma ist strikt untersagt, gemäß den EU Gesetzen für Copyrights und geistiges Eigentum.

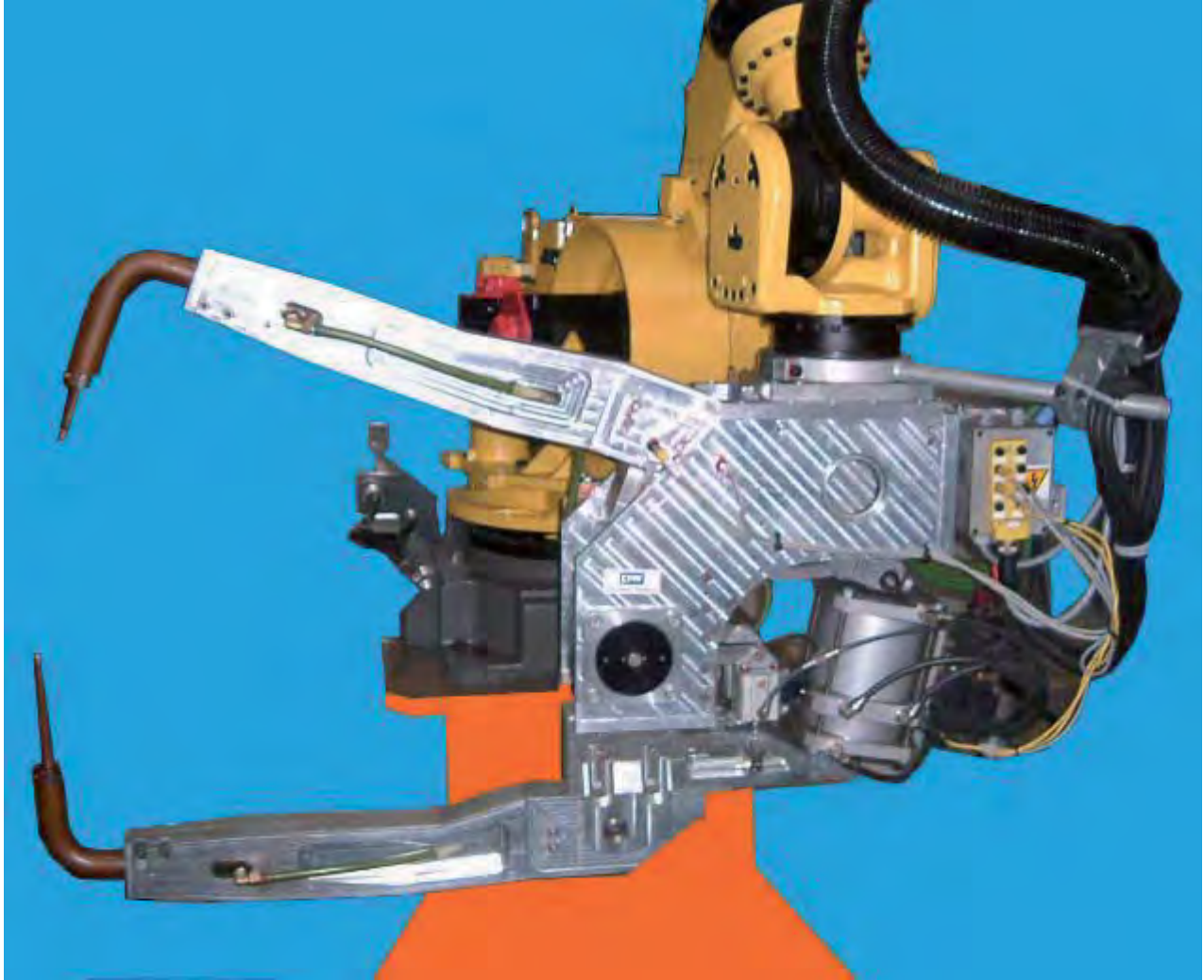

Ce document est la propriété exclusive de la société ALESSIO (I). La reproduction ou l'utilisation de ce document par des tiers sans une autorisation écrite de la société est interdite selon les lois CE sur la propriété intellectuelle et le copyright.  
Questo documento è proprietà esclusiva del Consorzio ALESSIO (I). Ne è pertanto vietata la riproduzione o l'utilizzo con qualsiasi mezzo senza il consenso del consorzio stesso ai sensi delle leggi CE sulla proprietà intellettuale e sul copyright.



This document is exclusive property of ALESSIO (I). Reproduction or use by a third party without written consent of the company is strictly forbidden, according to EC intellectual property and copyright laws.  
Dieses Dokument ist exklusives Eigentum von ALESSIO (I). Reproduktion oder Verwendung durch Dritte ohne schriftliche Zustimmung der Firma ist strikt untersagt, gemäß den EU-Gesetzen für Copyrights und geistiges Eigentum.

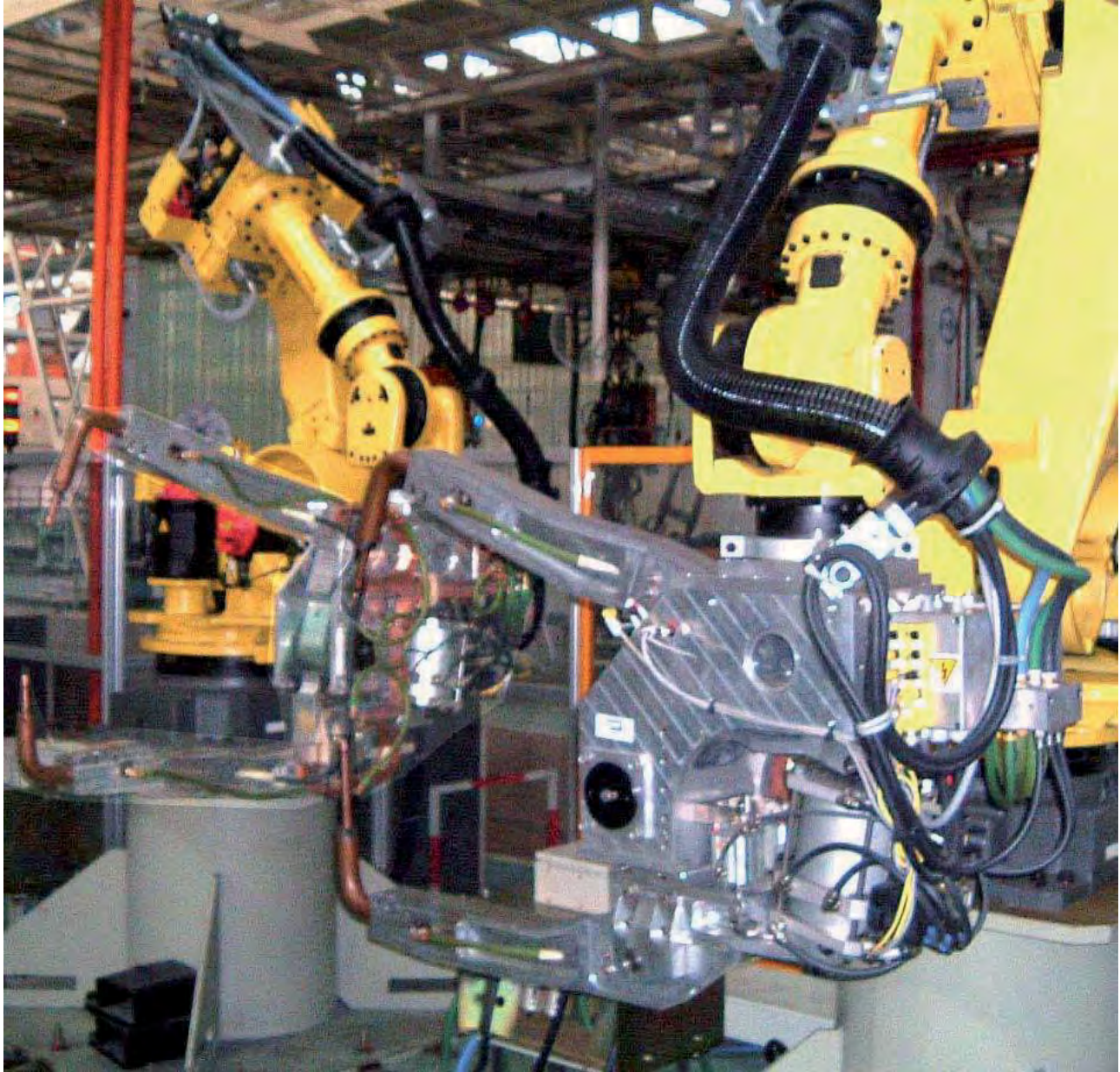

Ce document est la propriété exclusive de la société ALESSIO (I). La reproduction ou l'utilisation de ce document par des tiers sans une autorisation écrite de la société est interdite selon les lois CE sur la propriété intellectuelle et le copyright.  
Questo documento è proprietà esclusiva del Consorzio ALESSIO (I). Ne è pertanto vietata la riproduzione o l'utilizzo con qualsiasi mezzo senza il consenso del consorzio stesso ai sensi delle leggi CE sulla proprietà intellettuale e sul copyright.





This document is exclusive property of ALESSIO (I). Reproduction or use by a third party without written consent of the company is strictly forbidden, according to EC intellectual property and copyright laws.  
Dieses Dokument ist exklusives Eigentum von ALESSIO (I). Reproduktion oder Verwendung durch Dritte ohne schriftliche Zustimmung der Firma ist strikt untersagt, gemäß den EU-Gesetzen für Copyrights und geistiges Eigentum.

Ce document est la propriété exclusive de la société ALESSIO (I). La reproduction ou l'utilisation de ce document par des tiers sans une autorisation écrite de la société est interdite selon les lois CE sur la propriété intellectuelle et le copyright.  
Questo documento è proprietà esclusiva del Consorzio ALESSIO (I). Ne è pertanto vietata la riproduzione o l'utilizzo con qualsiasi mezzo senza il consenso del consorzio stesso ai sensi delle leggi CE sulla proprietà intellettuale e sul copyright.